

# Kawasaki

## 500 H1-D

RIDER'S HANDBOOK

## FOREWORD

We wish to thank you for choosing this fine Kawasaki Motorcycle. It is the end product of Kawasaki's advanced engineering, exhaustive testing, and continuous striving for superior reliability, safety, and performance. And by giving your motorcycle the proper care and maintenance outlined in this handbook, you will ensure it a long, trouble-free life.

In addition to this rider's handbook, factory-issued Shop Manuals are available for purchase from your Kawasaki Dealer. The shop manuals contain detailed repair and adjustment procedures, as well as additional specifications for each model. However, please note that during the warranty period, repair or adjustment by other than an authorized Kawasaki Dealer may invalidate your warranty.

**KAWASAKI HEAVY INDUSTRIES, LTD.**  
**MOTORCYCLE DIVISION**

# TABLE OF CONTENTS

Specifications .....	6	9. Trip Meter .....	18
Stopping Distance and Passing Time .....	10	10. Throttle Friction Adjuster ...	18
Controls .....	13	11. Steering Lock .....	19
1. Ignition Switch .....	13	12. Seat .....	19
2. Headlight .....	14	Fuel and Oil .....	20
3. Turn Signals .....	15	1. Fuel .....	21
4. Kill Switch .....	15	2. Engine Oil .....	21
5. Fuel Tank Cap .....	16	3. Transmission Oil .....	23
6. Fuel Tap .....	16	Breaking In .....	25
7. Steering Damper .....	17	Operation .....	26
8. Rear Shock Absorber .....	17	1. Starting the Engine .....	26
		2. Starting Out, Shifting Gears .....	28

3. Braking .....	30
4. Parking .....	30
Maintenance and Adjustment .....	31
1. Headlight .....	32
2. Steering .....	33
3. Clutch .....	34
4. Brakes .....	35
5. Drive Chain .....	38
6. Wheels .....	40
7. Tires .....	41
8. Spark Plugs .....	42
9. Air Cleaner .....	44

10. Carburetor and Related Adjustments .....	46
11. Ignition Timing .....	50
12. Battery.....	53
13. Mufflers .....	54
14. Cleaning .....	55
15. Storage.....	57
16. Lubrication .....	59
Troubleshooting Guide.....	61
Daily Checklist .....	62
Periodic Maintenance Chart .....	63
Wiring Diagram.....	Inside back cover

# 500 Model H1-D

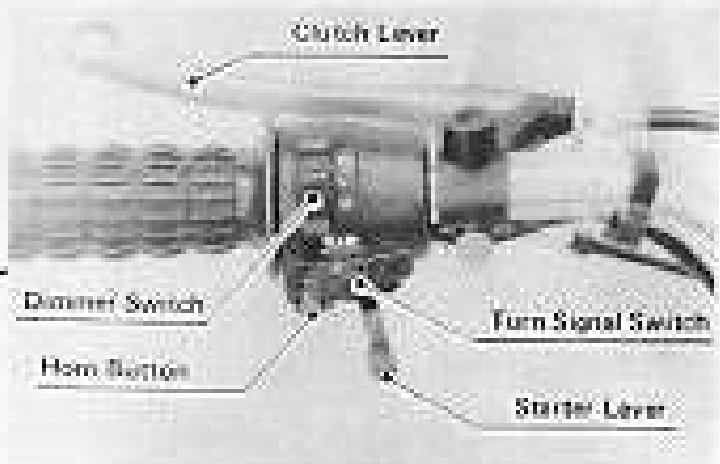

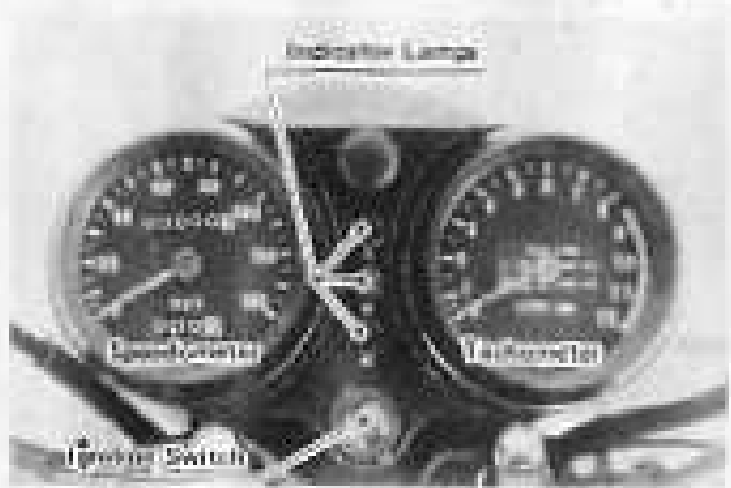
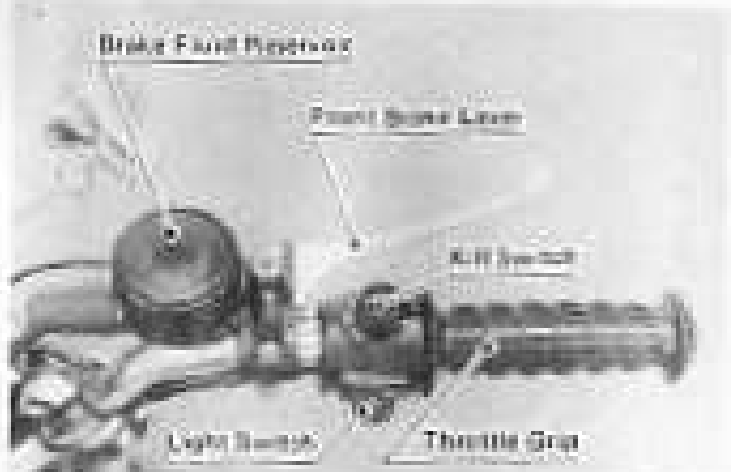

# SPECIFICATIONS

## PERFORMANCE

Acceleration SS ¼ mile (0-400 M)	12.4 sec.
Maximum Horsepower	59 hp @ 8,000 rpm
Maximum Torque	41.2 ft-lb @ 7,000 rpm (5.7 kg-M @ 7,000 rpm)
Climbing Ability	40°
Fuel Consumption	55 mi/U.S. gal. @ 50 mph *90 mi/imp. gal. @ 30 mph
Minimum Turning Radius	90 in. (2.3 M)
Braking Distance	35 ft. @ 31 mph (10.5 M @ 50 kph)
Maximum Speed	124 mph (200 kph)

## ENGINE

Type	2 cycle, 3 cylinder, piston valve
Displacement	30.4 cu. in. (498 cc)
Bore x Stroke	2.36 x 2.31 in. (60 x 58.8 mm)
Compression Ratio	6.8:1
	*European model

Ignition Timing

23° Before TDC

Starting

Kick

Lubrication

Injectolube (Oil injection)

Spark Plug

NGK B-9HS-10

Carburetor

Mikuni VM28SC

Ignition System

Electronic CDI

## TRANSMISSION

Type

5-speed, constant-mesh, return shift

Clutch

Wet, multi-disc

Primary Reduction Ratio

2.41

Final Reduction Ratio

3.00 (15/45)

\*2.81 (16/45)

Overall Reduction Ratio

5.84 \*5.47

Gear Ratios 1st

2.20

2nd

1.40

3rd

1.09

4th

0.92

5th

0.81

\*European m.s.



Transmission Oil		1.3 qt. (1.2ℓ) of SAE 10W30
<b>DIMENSIONS</b>		
Overall Length		82 in. (2,085 mm) *83.7 in. (2,125 mm)
Overall Width		33 in. (835 mm) *32.5 in. (825 mm)
Overall Height		45 in. (1,140 mm) *43.3 in. (1,100 mm)
Wheelbase		55.5 in. (1,410 mm)
Ground Clearance		5.7 in. (145 mm)
Dry Weight		407 lb. (185 kg)
<b>FRAME</b>		
Type		Tubular, double cradle
Suspension	Front	Telescopic fork
	Rear	Swing arm
Tire Size	Front	3.25-19 4PR
	Rear	4.00-18 4PR
		*European model

Brake Disc Dimensions (front)	11.65 in. (296 mm), single
Brake Drum Dimensions (rear)	7.1 x 1.4 in. (180 x 35 mm)
Fuel Tank Capacity	4.2 US gal. (3.5 imp. gal. or 16ℓ)
Oil Tank Capacity	2.5 US qt. (2.3ℓ)
Castor	63°
Trail	4.3 in. (108 mm)

## ELECTRICAL EQUIPMENT

Battery	12V 9AH
Head Lamp	12V 35/25W
	†12V 35/35W *12V 36/36W
Tail/Brake Lamp	12V 8/25W
	*12V 5/21W
Turn Signal Lamps (4)	12V 32cp *12V 23W
Meter Lamps (2)	12V 3W
Neutral Indicator Lamp	12V 3W
Turn Signal Indicator Lamp	12V 3W
High Beam Indicator Lamp	12V 1.5W

\*European model †Germany ‡France

# STOPPING DISTANCE AND PASSING TIME

## Vehicle Minimum Stopping Distance on Dry Pavement

These figures indicate braking performance that can be met or exceeded by the vehicle to which they apply, without locking the wheels, under different conditions of loading. The information presented represents results obtainable by skilled drivers under controlled road and vehicle conditions, and the information may not be correct under other conditions.

Description of vehicle to which this table applies: Model H1-D

### A. Fully Operational Service Brake

Load: Light

143

Maximum

149

0 50 100 150 200

Stopping distance in feet from 60 mph.

Manufacturer: Kawasaki Heavy Industries, Ltd.

## Acceleration and Passing Ability

These figures indicate passing times and distances that can be met or exceeded by the vehicle to which they apply, in the situations diagrammed on the next page.

The low-speed pass assumes an initial speed of 20 mph and a limiting speed of 35 mph.

The high speed pass assumes an initial speed of 50 mph and a limiting speed of 80 mph.

**Note:** The information presented represents results obtainable by skilled drivers under controlled road and vehicle conditions, and the information may not be correct under other conditions.

Description of vehicle to which this table applies: Model H1-D

### Summary Table:

Low-speed pass	376 feet;	7.7 seconds
High-speed pass	929 feet;	9.1 seconds

# Graphic Determination of Passing Time and Distance

LOW SPEED PASS

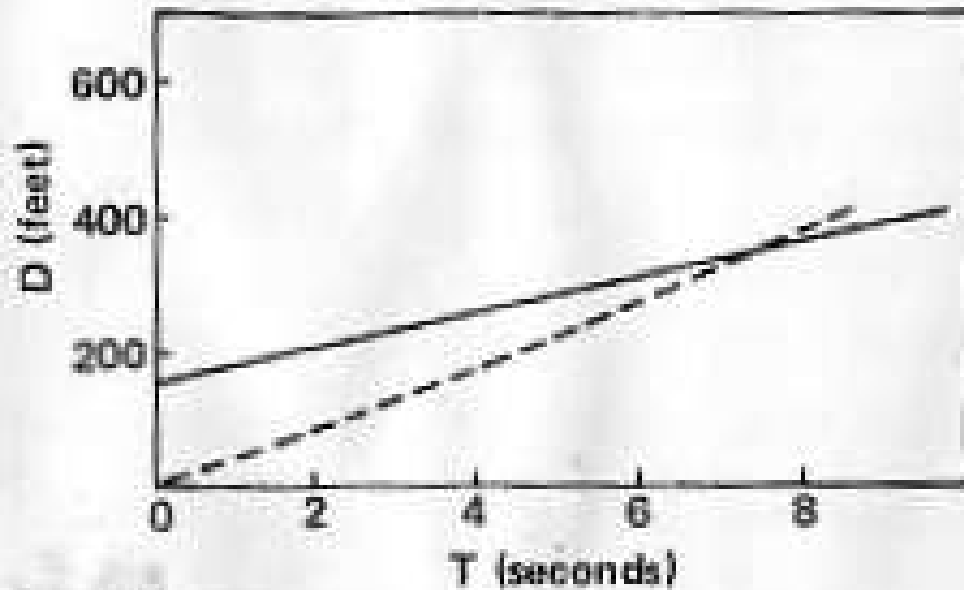

HIGH SPEED PASS

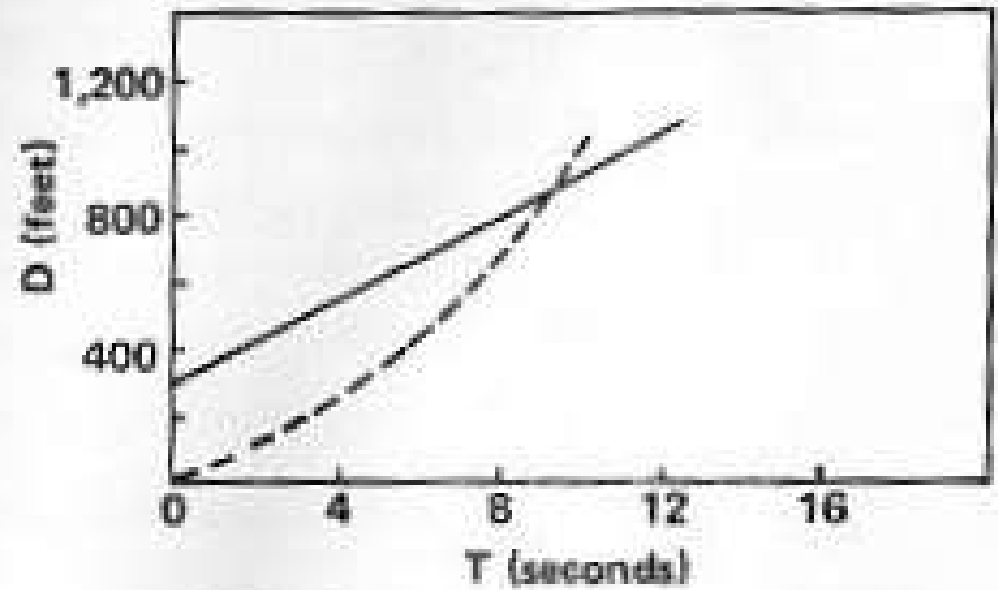

LOW SPEED

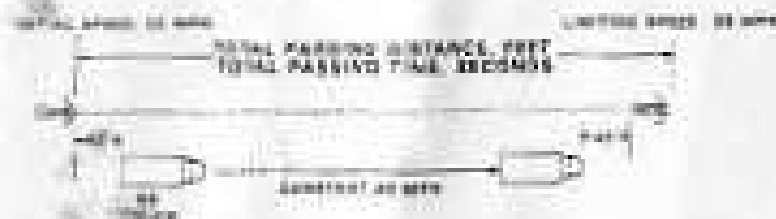

HIGH SPEED

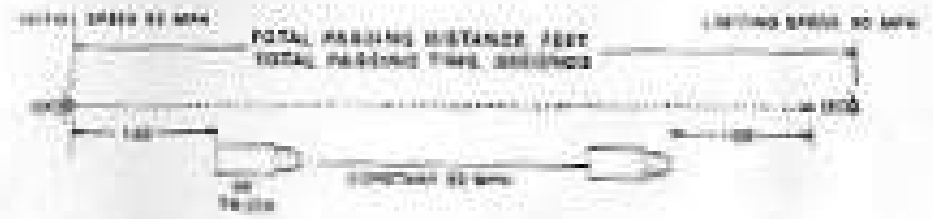

# CONTROLS

## 1. Ignition Switch

This is a three-position, key-operated switch. The key can be removed from the switch when it is in the Off or Park position.

Off	Engine off. All electrical circuits off. Key can be removed.
On	Engine on. All electrical equipment can be used. Key cannot be removed.
Park	Engine off. Tail light on. All other electrical circuits cut off. Key can be removed.

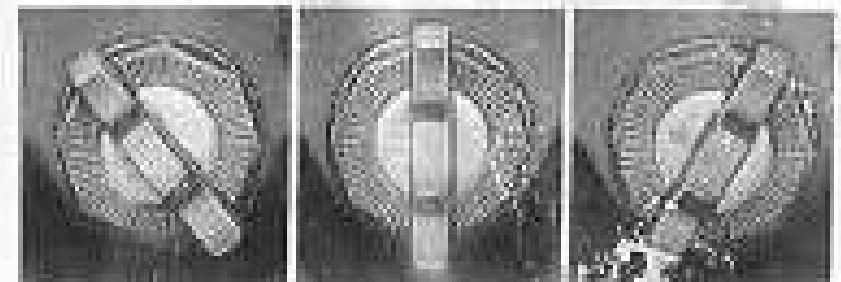

OFF

ON

PARK

## 2. Headlight

With the ignition switch turned on, the headlight switch will turn on the headlight on the left side of the handlebars.

High or low beam is selected by the dimmer switch. When the headlight is on high beam, the blue indicator on the light panel lights.

On the European models, a 4 watt lamp is mounted inside the semi-sealed headlight housing, in addition to the standard head lamp. This "city" lamp can be used for driving at dusk, or where the law requires a dim headlight for city driving after dark.

The front city light is turned on together with the tail light, by turning the headlight switch to the PO position.

In addition, European models have a spring-loaded third position of the dimmer switch. When the dimmer switch is pushed up from the low beam position, the high beam "passing" light comes on until the switch is released.

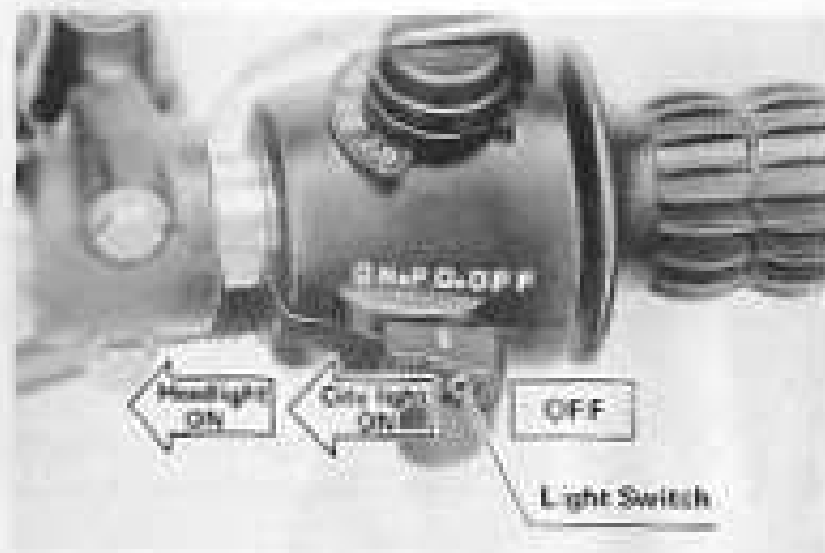
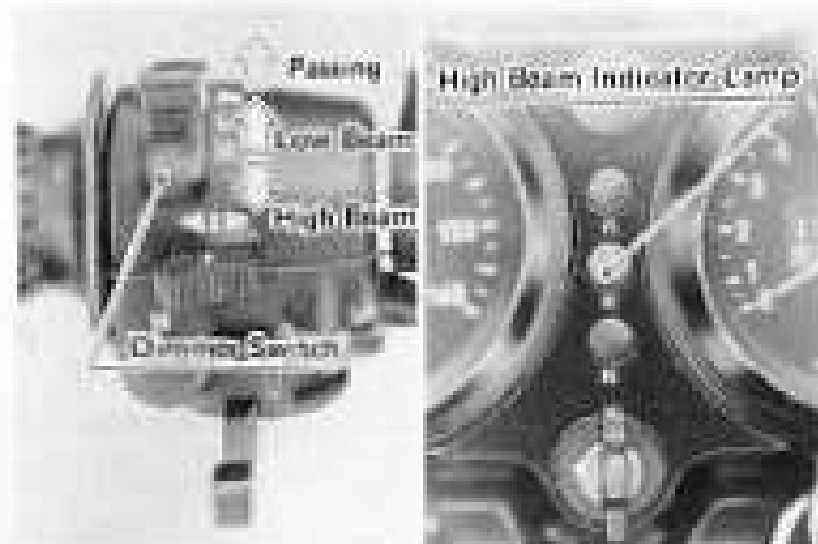

### 3. Turn Signals

The turn signals are controlled by a switch located on the left side of the handlebars. An orange lamp in the light panel flashes on and off with the turn signals to confirm that they are working properly. If the indicator lamp lights but does not flash, either one of the turn signal lamps is burned out, the battery is discharged, or the turn signal wires or ground connection may be bad.

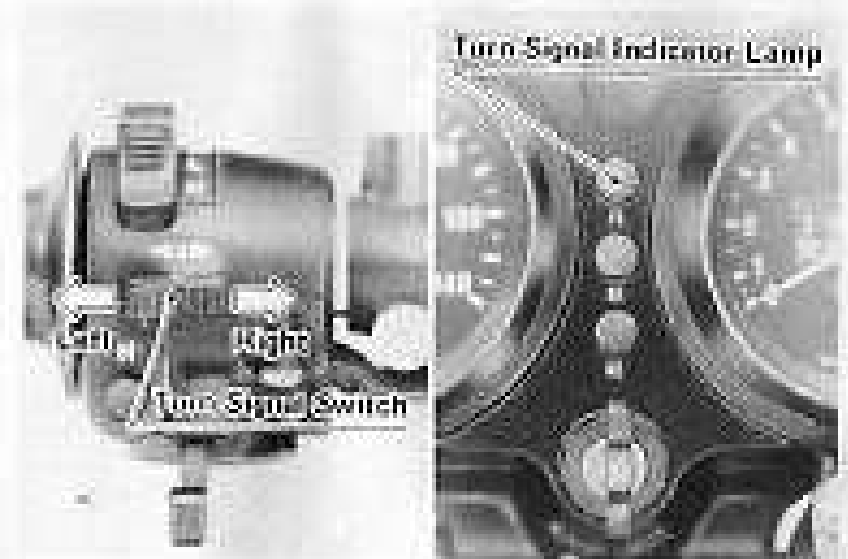

### 4. Kill Switch

To start and run the engine the kill switch must be turned to the **RUN** position, and the ignition switch must also be on.

If the throttle sticks open or if some other conditions require emergency engine stoppage, flick the kill switch to either of the **OFF** positions.

**Note:** The kill switch stops the engine but does not turn off all electrical circuits, so turn the ignition switch off before leaving the motorcycle.

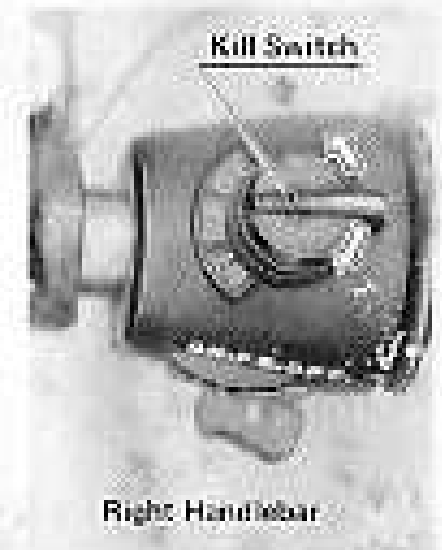



## 5. Fuel Tank Cap

To open the fuel tank cap push the cap down, pull up on the catch, and release the cap. To avoid damaging the cap when closing it, first lift up the catch, then push the cap down, release the catch, and last release the cap.

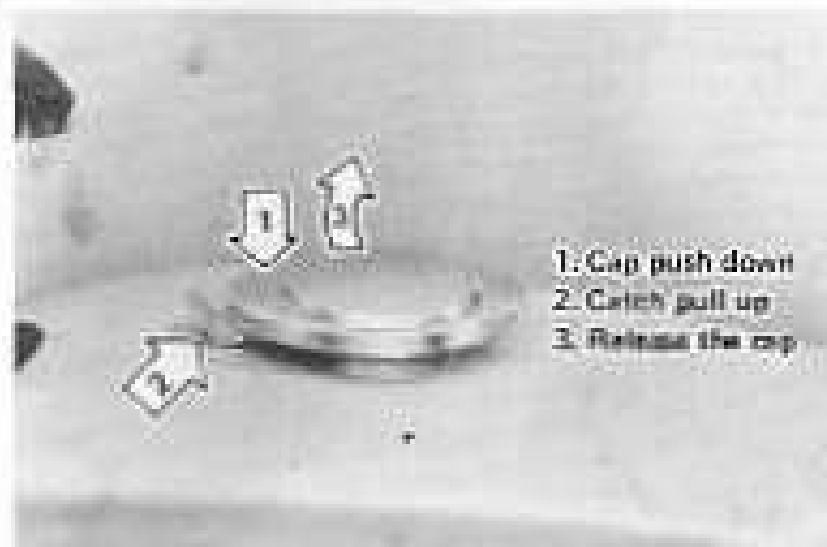

## 6. Fuel Tap

The fuel tap is an automatic type which shuts off the fuel supply when the engine is stopped.

In the ON position, the tap allows gasoline flow until a  $\frac{1}{2}$  U.S. gallon ( $\frac{1}{4}$  liter) reserve remains. By turning the tap to RES (reserve) the remaining gasoline can be used until the tank is empty.

The PRI (prime) position bypasses the automatic control and useful for priming the engine after running out of gas, or for completely draining the tank.

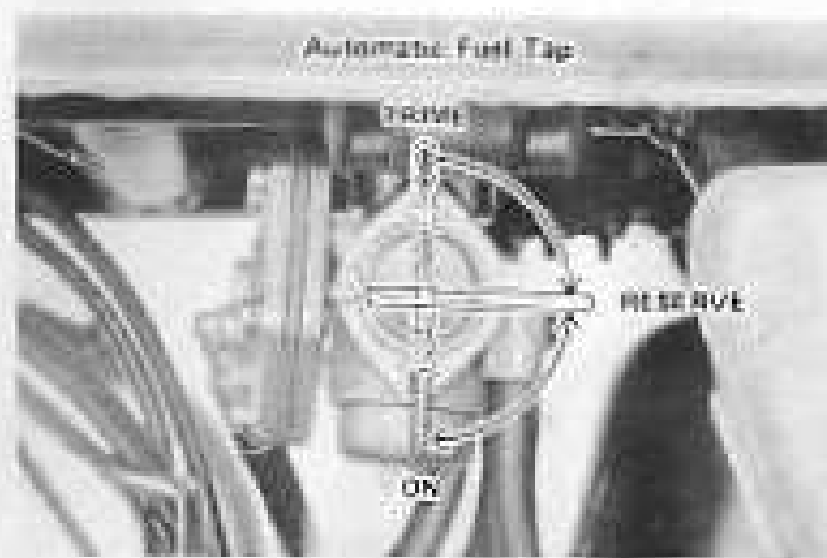

## 7. Steering Damper

The steering damper can be used to make the steering and handlebars less sensitive to vibration and road surface irregularities during high speed conditions. During travel on bad roads or at low speeds, the steering damper should be loosened for better and more effortless handling.

The steering damper is adjustable in 5 steps, so that it can be matched to riding condition. Turning the steering damper clockwise, the steering is less sensitive.

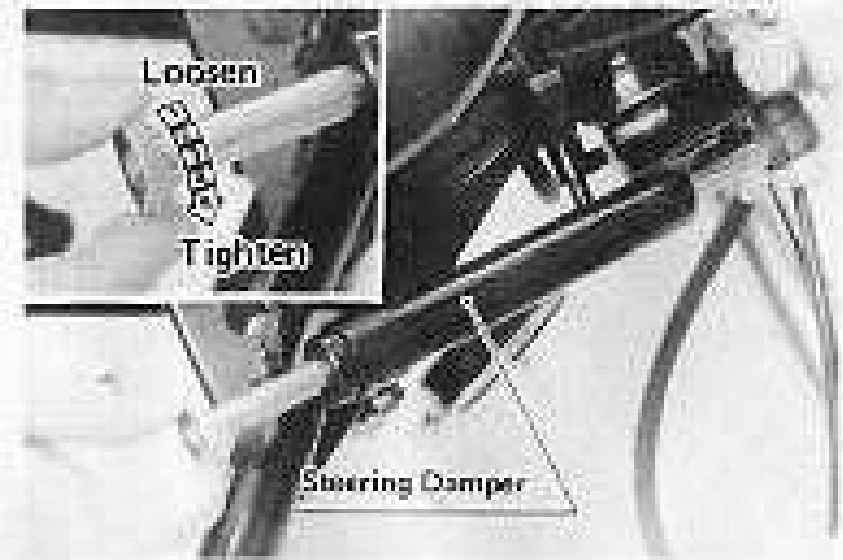

## 8. Rear Shock Absorbers

The rear shock absorbers are adjustable in 3 steps, so that they can be matched to road and loading conditions. Position 1 in the photograph is the softest position, and position 3 is the hardest.

For higher speeds and for heavier riders, adjust the shock absorbers hard. But when making adjustments, always be sure to adjust both left and right shock absorbers to the same position.

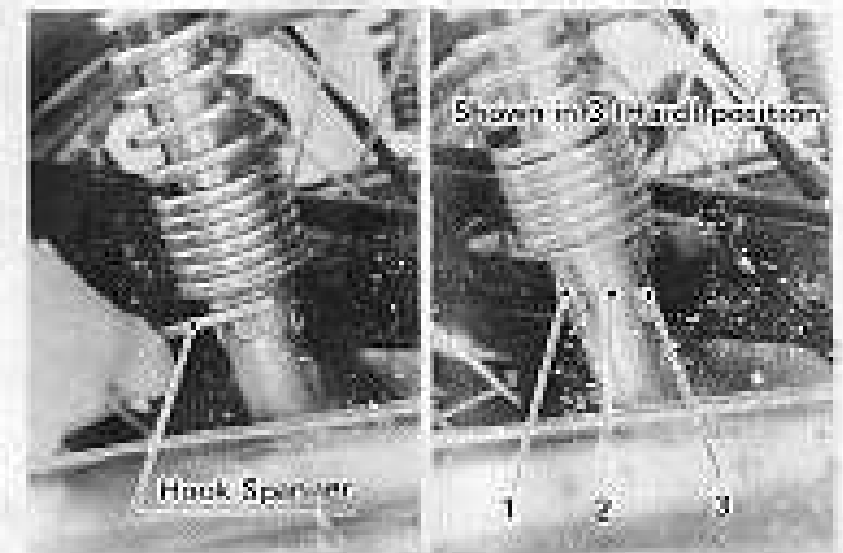

## 9. Trip Meter

The trip meter indicates distance traveled since it was last reset to zero. To reset it, turn the knob on the bottom of the speedometer until the trip meter reads zero.



## 10. Throttle Friction Adjuster

The throttle friction adjuster under the throttle grip makes long-distance riding even more effortless.

With the adjuster turned out, throttle action is normal. By turning it in, throttle grip friction can be increased to where the grip will remain in any position to which it is turned.

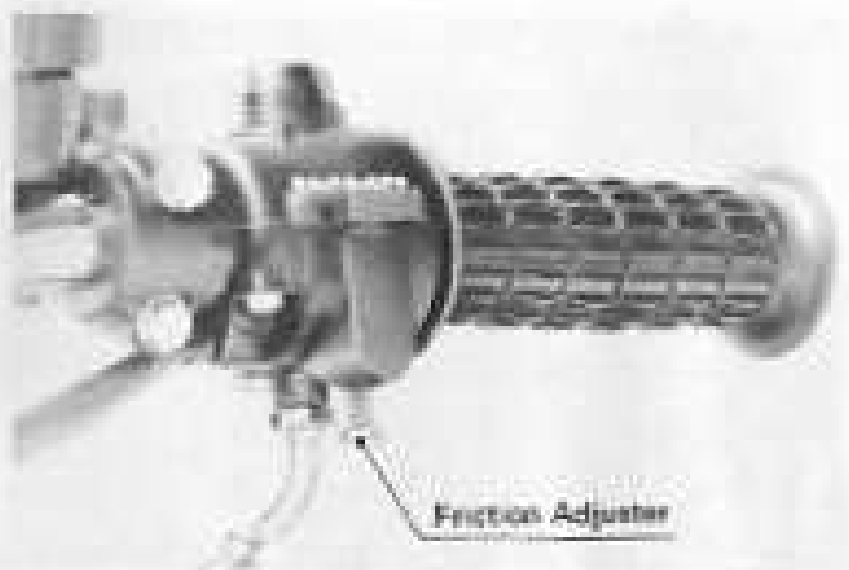

## 11. Steering Lock

When the motorcycle is parked, the steering can be locked in the full right or full left position with the lock located under the headlight. To lock the steering, turn the handlebars to one side, turn the auxiliary key to the left, push it in, turn it to the right and remove it!





## 12. Seat

The seat is hinged so that it can be swung open for access to the tools or wiring.

Push the seat catch in and lift the seat to open it. The seat can be locked closed by inserting the auxiliary key in the seat lock and turning it  $\frac{1}{4}$  turn to the right.



## FUEL AND OIL

Location	Fuel Tank	Oil Tank	Transmission
Fuel or Oil	 <p>Regular Gasoline (85 octane minimum)</p>	 <p>2 cycle engine oil recommended for air-cooled engines</p>	 <p><u>Motor Oil</u> Summer: SAE 30 Winter: SAE 20 All seasons: SAE 10W30</p>
Capacity	16 liters (4.2 U.S. gallons)	2.3 liter (2.5 U.S. quart)	1.2 liter (1.3 U.S. quart)

## 1. Fuel

The Kawasaki Injectolube system is used in this motorcycle, so it is not necessary to mix oil with the gasoline. Use only regular gasoline in the gas tank.

**Caution:** ●Avoid filling the tank in the rain.

●Never fill the tank completely to the top. As the gasoline expands while the motorcycle is running, it may overflow from the vent in the tank cap.

●Always put in gasoline with the engine turned off, and the motorcycle away from any source of sparks.

## 2. Engine Oil

### 1) Type of oil

Use any good quality 2 cycle engine oil recommended for air-cooled engines. One absolute requirement for the 2 cycle oil used in the Injectolube system, is that it must flow readily at low temperatures.

**Caution:** Do not use ordinary motor oil, transmission oil, or the like as a replacement for the proper oil; this is the cause of many engine troubles.

## 2) Adding oil

On the side of the oil tank there is a window for checking the oil level, and 1 liter (1 U.S. quart) of oil should be added when the level reaches the middle of this window, with the motorcycle standing vertical. Avoid adding oil with the motorcycle standing in the rain.

**Caution:** Never let the oil tank run completely dry. If the tank does run dry, air will enter the oil pipe, and putting oil in at this point will still not prevent the engine from running a few minutes without oil while the air is pumped out. At high speed, this could lead to serious engine damage.

## 3) Bleeding the lines

If air or water enters the oil lines, bleed them as follows: (1) Loosen the pump intake pipe until the air or water drains out of the pipe, then tighten it; (2) Run the engine at idle speed while pushing the pump lever fully open by hand until no air appears in the pump outlet pipes. See illustrations on page 48.



### 3. Transmission Oil

The transmission oil performs the dual function of lubricating the wearing surfaces, and keeping the transmission cool. A good quality SAE 20 or 30 oil or multi-viscosity 10W30 oil should be used.

#### 1) Oil Level

Check the oil level with the dipstick on the filler hole plug. (If the motorcycle has just been used, wait 2 or 3 minutes for the oil to drain down before measuring it.) When the motorcycle is standing vertically (not using the side stand), and the dipstick is inserted into the hole and screwed in, the oil level should be between the upper and lower level marks on the stick.

If there is not enough transmission oil, the transmission and clutch may overheat and be damaged, and the parts will wear quickly; if there is too much oil there will be a drop in engine power, and the clutch may not release well.

**Note:** If it is necessary to add oil frequently, have the Dealer check the motorcycle for trouble.





## 2) Oil change

The first oil change is designated to be performed after 500 miles (800 km), which may seem to be an exceptionally short distance. However, an oil change at this point is necessary because as the various gears seat with each other, and as the clutch parts wear in, filings collect in the oil. If this dirty oil is not drained out, it will hasten transmission and clutch wear. After the initial few hundred miles, wear is comparatively negligible and the fresh oil can be left in until the 2,000 mile (3,000 km) oil change with no ill effects.

After the first 500 mile (800 km) and 2,000 mile (3,000 km) oil changes, change the oil every 2,000 miles (3,000 km).

To change the oil:

- Warm up the engine thoroughly so that the oil will pick up any sediment and drain easily.
- Remove the drain plug and stand the motorcycle vertically so that the oil will drain completely.
- Replace the plug and fill the transmission with 1½ quarts (1.2 litre) of the specified motor oil.

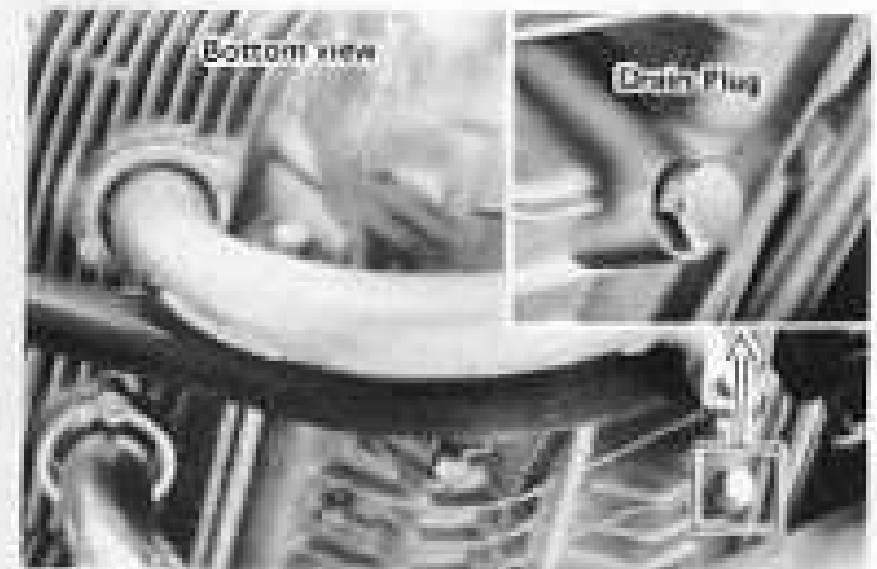

## BREAKING IN

Kawasaki Motorcycles are precision manufactured and made to last. But unreasonably hard riding during the 1,000 mile (1,600 km) break-in period will greatly shorten the life of the vehicle.

The 1,000 mile (1,600 km) break-in period is not only for the longevity of the engine, but for the sake of the chain, sprocket, brakes, and the entire vehicle. Therefore, engine speed should be limited to 4,000 r.p.m. for the first 500 miles (800 km), and must be kept under 6,000 r.p.m. from the 500 mile (800 km) mark until 1,000 miles (1,600 km) is reached.

**Caution:** ●Especially for first to third gears, the gear ratio and engine response make it very easy to raise engine speed above the specified limit, so please watch the tachometer closely.

- Do not start moving or race the engine directly after starting up. Warm the engine up slowly and give the oil a chance to work into the engine.
- While the gears are in neutral, do not race the engine since this may damage the transmission.

Spark plugs may become fouled during the break-in period due to the slow driving required. Please refer to pages 42~43.

## OPERATION

### 1. Starting the Engine

The procedure for starting a cold engine is somewhat different from that for starting an engine when it is already warm, so please proceed according to the appropriate set of directions.

When the engine is cold:

- ✧ Turn on the fuel tap, and turn the ignition switch to the **ON** position.
- ✧ Check that the kill switch is in the **RUN** position.
- ✧ Make certain the gears are in neutral by seeing that the green light in the light panel is lit. When the engine is stopped, rolling the motorcycle slightly when operating the shift pedal makes gear shifting easier.
- ✧ Push the starter lever as far as it will go, leaving the throttle completely closed.

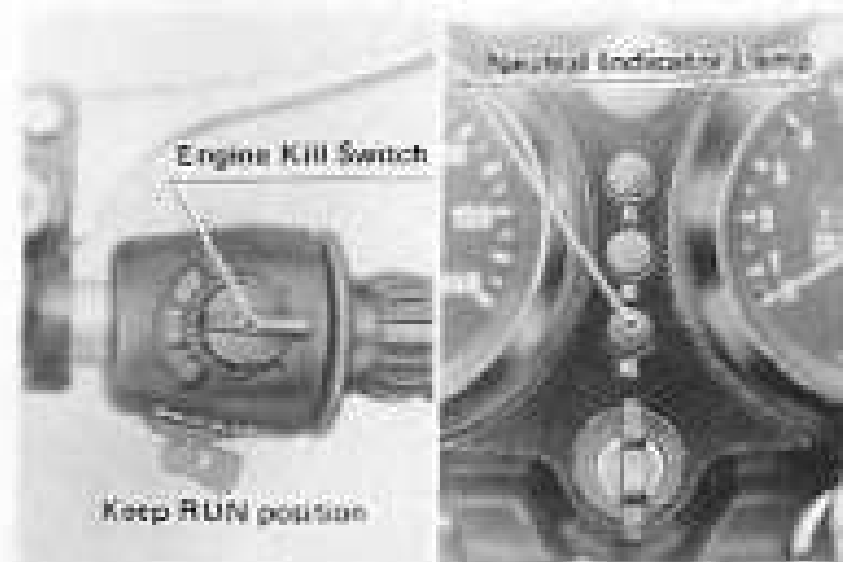

- ✧ Kick the starter pedal down smartly, and the engine will start.
- ✧ If the engine does not start after two or three attempts, release the starter lever and with the throttle  $\frac{1}{2}$  turn opened to let more air into the engine, kick the pedal again.
- ✧ When the engine starts, keep the starter lever pushed and twist the throttle a few times until you are sure the engine will not stall. (Don't race the engine over 3,000 r.p.m.) Then close the throttle and warm the engine at idle speed.
- ✧ If the clutch lever is pulled, the motorcycle can be started while still in any gear, but be careful to shift down to first or second gear before starting to move.
- ✧ As soon as the engine is warm enough to idle smoothly without use of the starter lever, release the lever and see if the engine will respond immediately to the throttle. If the response is sluggish, push the starter lever back over and twist the throttle several times until the engine is completely warmed up.

If you attempt to move the motorcycle without a sufficient warm-up period, you will encounter various problems: the clutch may not disengage properly and the motorcycle will jump when it is put into gear; or as you release the clutch, engine r.p.m. will suddenly drop and the engine may stall; acceleration will be erratic.

**When the engine is warm, or on hot days:**

- ☆ Turn on the fuel tap and the ignition switch, and make sure the gears are in neutral.
- ☆ Without using the starter lever, open the throttle about  $\frac{1}{4}$  turn and kick the pedal.
- ☆ Let the engine idle for about two minutes before starting out, even though it may already be warm enough. This is to give the oil pump a chance to put oil back into vital parts, and failure to do this will greatly shorten the life of the engine.
- ☆ If the engine should flood for some reason, hold the throttle full open to let air into the engine, and kick the pedal. Close the throttle back down as soon as engine r.p.m. starts to rise after starting.

## **2. Starting Out, Shifting Gears**

The transmission in this motorcycle is a 5-speed, constant-mesh, return-shift type.

Neutral is at the bottom of the shifting range, and 5th gear is at the top. Shifting is done one gear at a time using the gear shift pedal. Lift the pedal up fully and then release it to shift into a higher gear. Push the pedal down fully and release it to shift into the next lower gear.

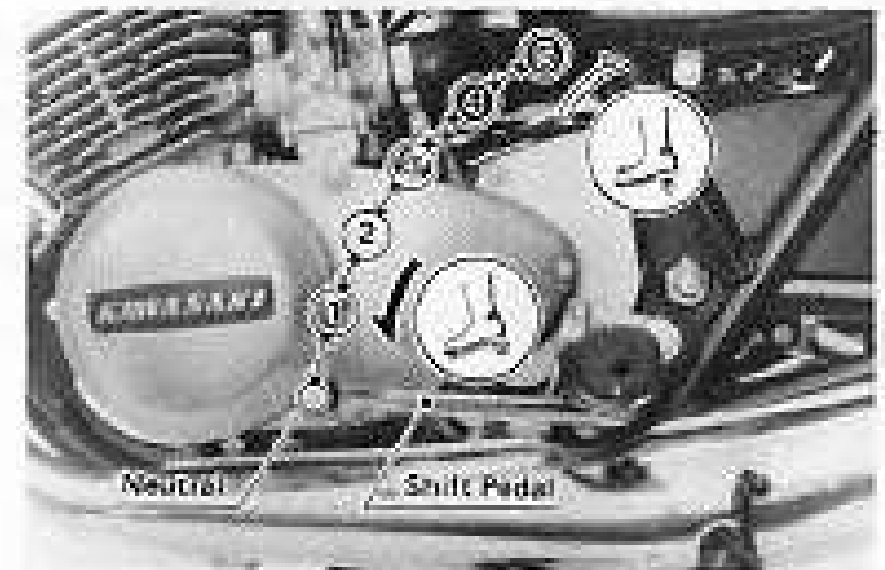

### **1) Starting out**

When you have determined that the engine has been thoroughly warmed up, return the throttle grip to the fully closed position. Pull in the clutch lever and lift up the pedal to shift into first gear. Twist open the throttle slightly to raise the engine speed, and at the same time let out slowly on the clutch lever. If the motorcycle starts out with a jerk, you have released the clutch lever a little too fast.

### **2) Acceleration**

After gaining enough speed in first gear, squeeze in the clutch lever and at the same instant close the throttle completely. Lift up on the shift pedal to change into second gear, then open the throttle and release the clutch lever simultaneously. Shifting up to third, fourth and fifth gears is done in this same manner.

### **3) Deceleration**

Close the throttle and apply the front and rear brakes together. When the desired speed is reached, disengage the clutch, push down on the pedal to shift into the next lower gear, and then open the throttle and release the clutch lever together. Shifting down is done in the same quick operation as shifting up.

**Caution:** Sudden down shifting at too high a speed causes an abrupt increase in engine speed and could damage the engine, as well as being dangerous to the rider.

**Note:** ●During deceleration, the vehicle speed and engine r.p.m. should be kept below the limit for each gear, as set forth in the table.

●Avoid traveling at engine speeds below 3,000 r.p.m. Not only is this speed insufficient to charge the battery properly, but engine power and throttle response are considerably reduced, and constant driving at low engine speed will foul the spark plugs.

Downshift below these speeds		
Gear Shift	mph	kph
5 <sup>th</sup> to 4 <sup>th</sup>	93	150
4 <sup>th</sup> to 3 <sup>rd</sup>	77	125
3 <sup>rd</sup> to 2 <sup>nd</sup>	62	100
2 <sup>nd</sup> to 1 <sup>st</sup>	40	65

### 3. Braking

Close the throttle completely, and apply the front and rear brakes simultaneously. During sudden braking, never apply the front or rear brake alone. Using only one brake is extremely dangerous as it could cause the motorcycle to skid.

When turning or on a curve, it is better not to apply the brakes at all, but if this cannot be avoided, apply only the rear brake to minimize the danger of skidding.

### 4. Parking

When parking for a short time on the road at night, there is a convenient "Parking" position of the ignition switch which can be used for safety. In this position the tail lamp lights, and the key can be removed from the switch. When parking during the day, or for a long period at night (more than two hours), however, the switch should be turned to the "Off" position, since the parking light will run down the battery if left on too long.

## MAINTENANCE AND ADJUSTMENT

Regular inspection and adjustment is the key to maintaining your Kawasaki motorcycle in dependable condition, ready to answer your riding demands at a moment's notice. Some of these operations, such as front and rear brake adjustment, tire pressure check, and chain slack adjustment, are so important that you should make a habit of checking them frequently as explained on the following pages.

The tools are located in the compartment above the rear fender.

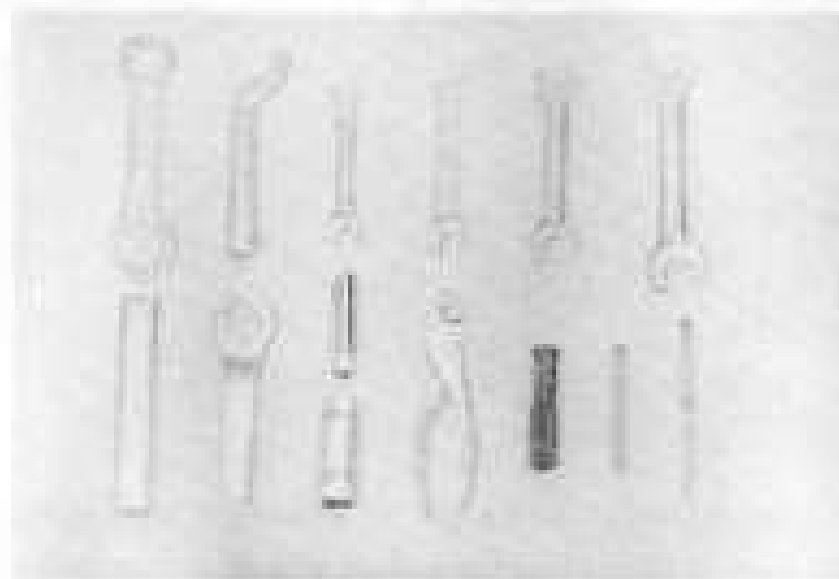



# 1. Headlight

Horizontal (right or left) adjustment is performed by turning the adjuster screw in the front of the headlight rim.

Adjust the beam higher or lower by first loosening the mounting bolts on the sides of the headlight, and moving the light by hand. After adjustment is complete, be sure to retighten the bolts.

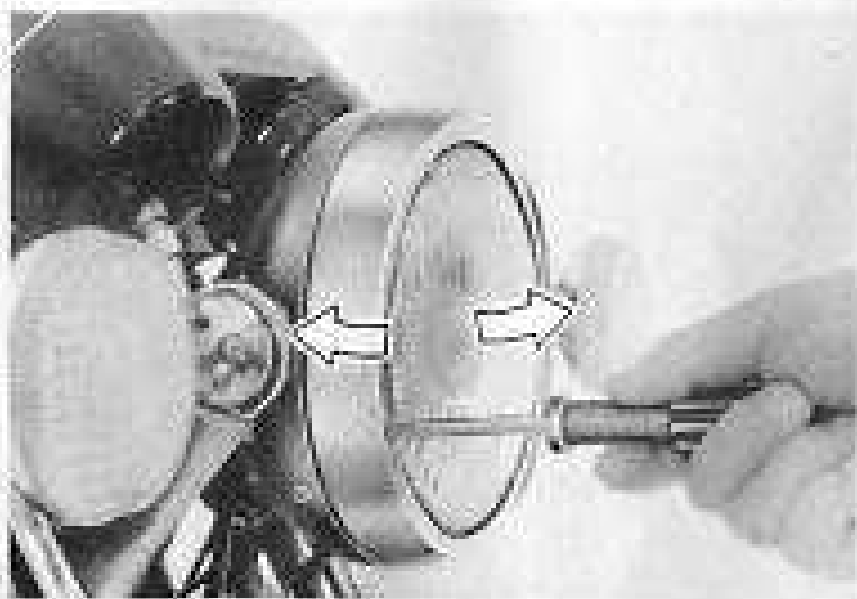

Left/Right Adjustment



Loosen bolts on either side to adjust headlight.

## 2. Steering

For safe riding, the handlebars should always be kept adjusted so that they will turn freely but have no play.

If they are adjusted too tightly, the handlebars will be hard to turn quickly, the motorcycle may pull to one side, and the steering stem bearings may become damaged.

If the steering has play, the handlebars will vibrate, and the motorcycle will be unstable and hard to steer in a straight line.

To check for correct steering adjustment, first place a stand or blocks under the engine to lift the front wheel off the ground. Push the handlebars lightly to either side; if they will continue moving under their own momentum, the handlebars are not too tight. Squatting in front of the motorcycle, grasp both ends of the axle and shake it back and forth; if no play is felt the steering is not too loose.

Steering adjustment can be made by loosening the stem head and one clamp bolt, and turning the steering stem nut with a spanner.

Then loosen the two lower fork tube clamp bolts at the bottom of the headlight housing, to let the fork tubes reseal themselves.

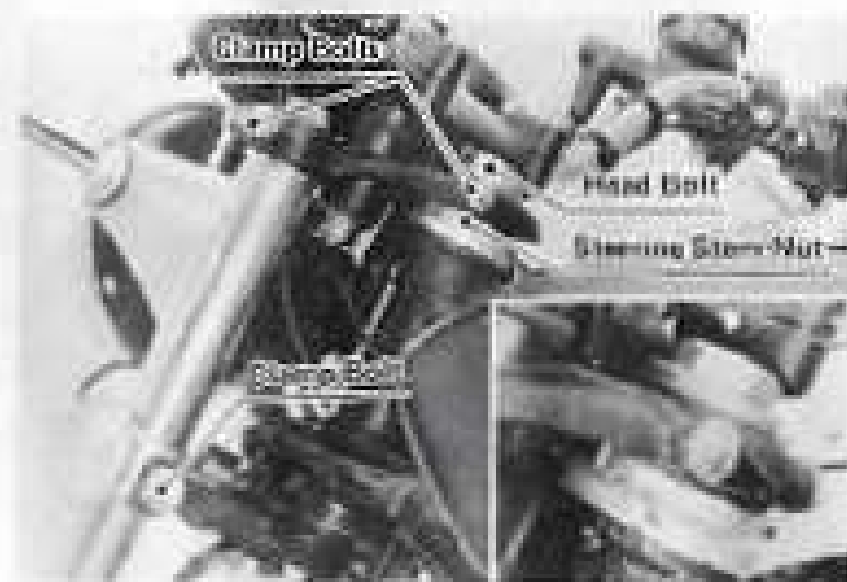

### 3. Clutch

The clutch friction plates wear and the clutch cable stretches over a long period of riding, so it is necessary to adjust the clutch release mechanism and clutch cable every 2,000 miles (3,000 km).

**Caution:** Improper adjustment can cause erratic gear shifting, clutch slippage, or incomplete clutch disengagement.

To adjust the clutch:

- Loosen the clutch release lever lock nut and back out the adjusting screw one or two turns to where the lever turns freely.
- Set the lever/cable angle at approximately  $80^\circ$  by turning the clutch cable adjuster.
- Screw the clutch release lever adjusting screw back in until you feel pressure, and lock it in that position.
- Adjust the clutch (hand) lever with the cable adjuster for  $1/16$  to  $1/8$  inch (2–3 mm) play before you start to feel clutch spring tension. Use the small hand adjuster for minor corrections while riding.
- Tighten all lock nuts.

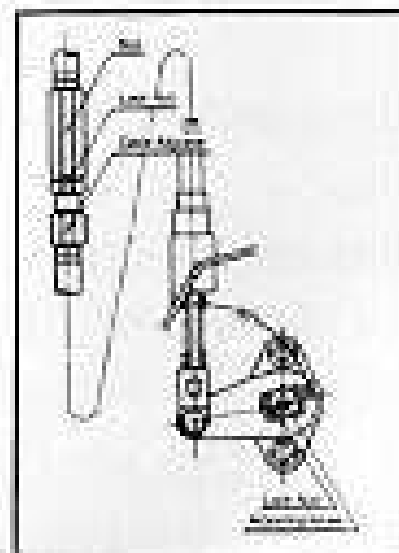

## 4. Brakes

Make these adjustments carefully as correct brake adjustment is vital to your riding safety.

### Front Brake

Since a disc brake is used on the front wheel, adjustment is unnecessary except for hand lever play. Play measured at the tip of the lever should be adjusted to less than  $3/16$  inch (5 mm), by turning the adjuster bolt. Be sure to fix the bolt in place with the lock nut.

If the brake line or any fitting shows damage, it should be replaced immediately. If dirt or corrosion appears in the oil or if the brake lever comes to within one inch (25 mm) of the handlebar grip during brake application, have the brake checked by a Kawasaki Dealer.

Always keep the brake fluid up to the line inside the reservoir held as close as possible to the horizontal. Brake fluid should be changed after one year or 6,000 miles (10,000 km), whichever

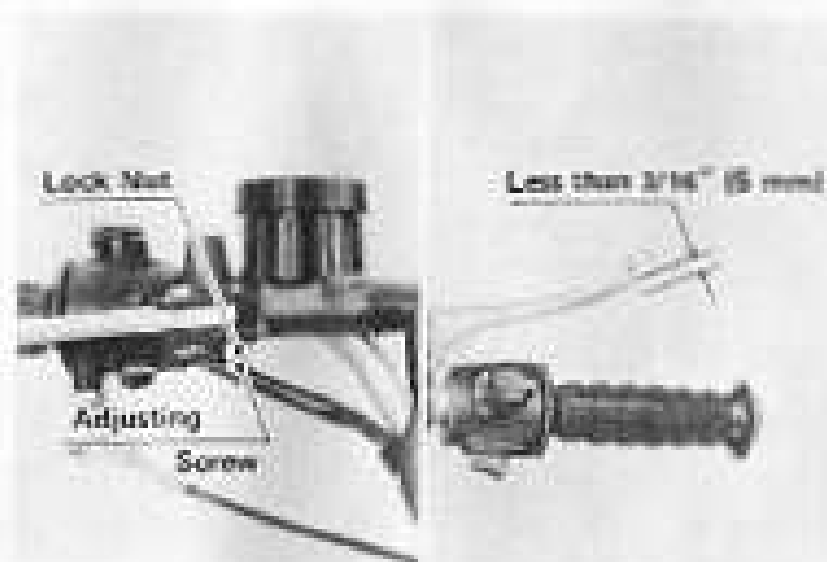

comes sooner. For replenishment or change, one of the recommended types of oil should be used.

Replace the brake pads if they become worn down through the red line.

When adding brake fluid, always use the same type as is already in the reservoir. If any oil spills on painted surfaces, it must be wiped off immediately. If water becomes mixed with the fluid, the brake fluid must be completely changed.

### Rear brake

First set the brake pedal to a comfortable position by loosening the lock nut and turning the adjuster bolt. Then adjust pedal play.

Turn the brake adjusting nut so the rear brake pedal has  $\frac{3}{4}$  to  $1\frac{1}{4}$  inches (20-30 mm) of travel from the rest position to the fully applied position. Next adjust the brake lamp switch.

### Recommended Disc Brake Oil

Atlas Extra Heavy Duty

Shell Super Heavy Duty

Texaco Super Heavy Duty

Wagner Lockheed Heavy Duty

Girling Amber

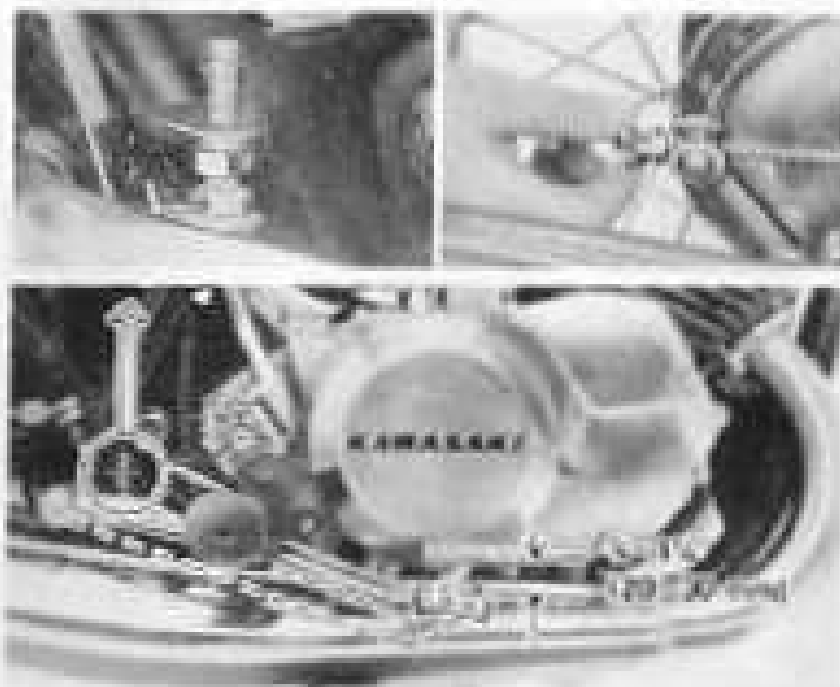

## Rear brake lamp switch

Check the operation of the brake lamp switch by turning on the ignition switch and depressing the brake pedal. The brake lamp must light about halfway through the brake pedal's range of movement, after  $\frac{1}{2}$  to  $\frac{3}{4}$  inch (15–20 mm) of pedal travel.

Adjust the switch by loosening the mounting nuts and moving the switch body up or down. Do not turn the switch body as the wires will be damaged. Don't adjust the switch so that it turns on as soon as the pedal is moved. Otherwise, in normal driving, you might rest your foot on the pedal enough to light the brake lamp continuously.

The brake lamp will also light when the front brake is applied, but as the front brake incorporates a pressure switch, adjustment is not necessary. Check the switch by pulling the hand brake lever with the ignition switch turned on.



Lights sooner



Lights later

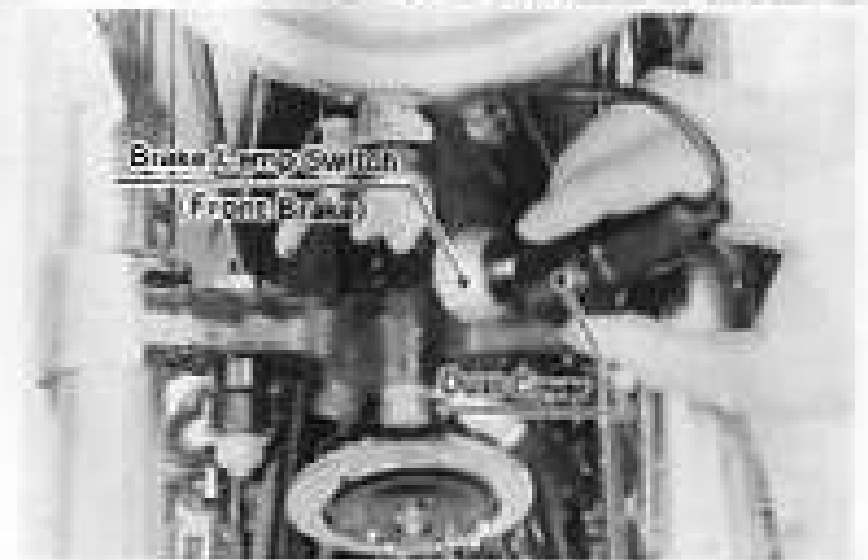

## 5. Drive Chain

The drive chain requires periodic inspection, lubrication and adjustment. If the chain is allowed to dry out or become maladjusted, it fails to move freely, wearing down the links and the front and rear sprockets, and putting a strain on the engine.

Oil the chain sparingly whenever necessary. Use enough oil to ensure smooth movement, but not so much that it will be thrown off and collect dirt.

Drive chain adjustment is checked with the motorcycle resting on the side stand. Moving the chain up and down, see that vertical movement at its greatest point is  $\frac{5}{8}$  to  $\frac{3}{4}$  inch (15~20 mm). If the chain is out of adjustment, re-adjust it according to the following procedure.

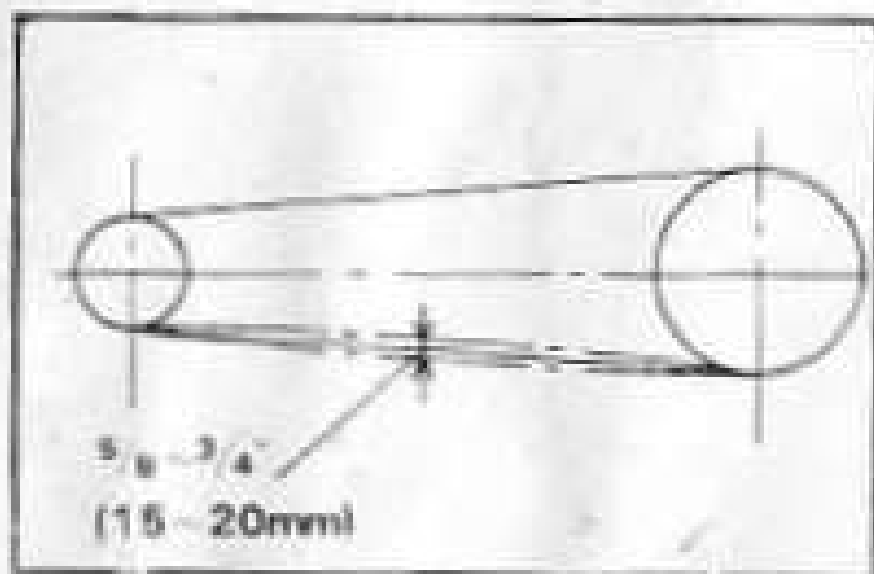

## Adjustment

- Remove the cotter pin and loosen the torque link nut.
- Loosen both chain adjuster lock nuts.
- Remove the cotter pin and loosen the rear axle nut.
- Screw in the chain adjuster nuts until chain slack at its greatest point is  $5/8 \sim 3/4$  inch (15~20 mm) with the motorcycle resting on the side stand. Make sure that the chain adjuster marks point to the same number swing arm alignment mark on each side.
- Tighten the axle and torque link nuts and replace their cotter pins.
- Tighten the chain adjuster lock nuts.

**Note:** After chain adjustment, check the rear brake and brake lamp adjustments, which are changed by chain adjustment.





## 6. Wheels

### Balance

The wheels must be balanced properly to prevent rider fatigue from annoying vibration at high speed.

With the drive chain removed from the rear wheel, check the balance by raising each wheel off the ground in turn, and spinning it lightly. The wheel is correctly balanced if it will come to a stop at any position. If you determine that the wheel requires balancing, proceed as follows.

☆ Attach a balance weight temporarily to the lightest side of the wheel and spin it again. Attach more weights as necessary and repeat the process until the difference between the heaviest and lightest sides of the wheel is within 1/3 ounce (10 grams). Less than this will not affect running stability.

☆ When any imbalance has been satisfactorily compensated for, attach the weights firmly with pliers.

Note: 10, 20 and 30 gram (1/3, 2/3 and 1 ounce) balance weights are available for purchase from Kawasaki Dealers.

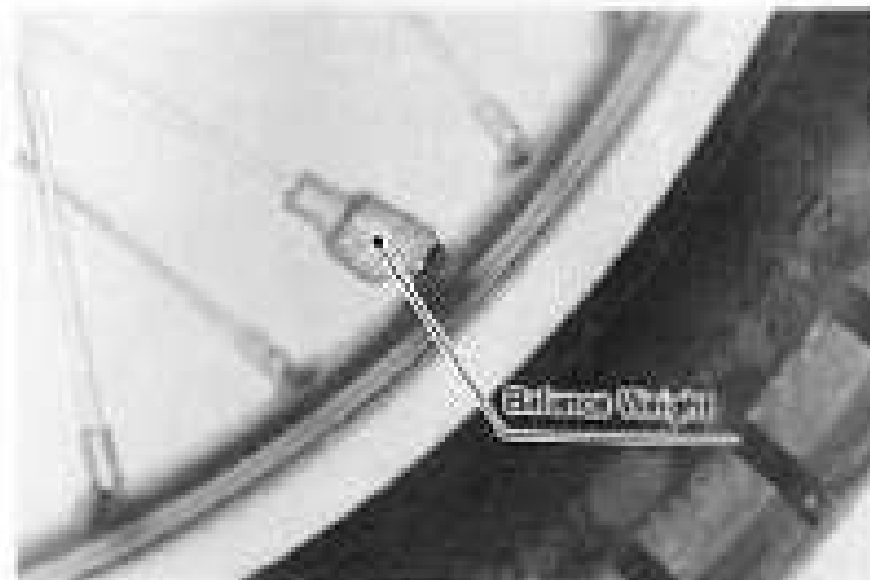

## Spokes

The spokes must be checked and tightened at regular intervals, especially during the break-in period. The rims should be straightened if warp exceeds 3 mm (.12 inch) to either side, or 2 mm (.08 inch) radially outward.

## 7. Tires

Abnormally high or low tire pressure has an adverse effect on maneuverability, and shortens tire life. Check the tire pressure at regular intervals, and keep it at the values given in the table.

When prying the tire off the rim, be sure to first loosen the nut of each bead protector, which keeps the tire from slipping on the rim. Make a chalk mark on the tire to show the location of the valve stem, so that the tire can be remounted in the same position and preserve wheel balance.

	Front	Rear
Tire Size	3.25-19 4PR	4.00-18 4PR
Air Pressure	26 psi (1.8 kg/cm <sup>2</sup> )	31 psi (2.2 kg/cm <sup>2</sup> )

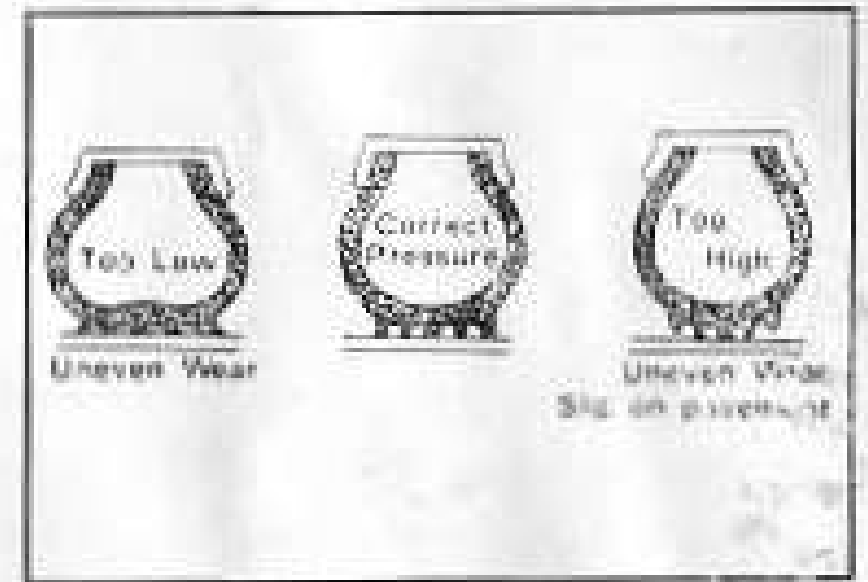

## 8. Spark Plugs

The standard spark plug is an NGK B-9HS-10 set with a .035~.039" (0.9~1.0 mm) gap, and installed with 18.5~21.5 ft-lbs (2.5~3.0 kg-M) torque. The spark plugs should be taken out every 2,000 miles (3,000 km) for cleaning and to reset the gap. If either electrode is badly worn down, the plug should be replaced.

For unusually slow riding such as break-in riding, or for unusually fast riding such as racing, hotter or colder spark plugs may be necessary. To find out whether the right temperature plugs are being used, pull them out and examine the ceramic insulator around the center electrode. If the ceramic is a light brown color, the spark plugs are correctly matched to engine temperature.

If the ceramic is burned white, the plugs should be replaced with NGK B-10H-10's which will run cooler. If the ceramic is black, the plugs are running too cold and hotter running NGK B-8H's should be used. The spark gap for either of these spark plugs is the same as for the standard plug.

**Caution:** When your type of riding changes — for example, a change to faster riding after the break-in period is over — the spark plugs should be inspected and changed if neces-

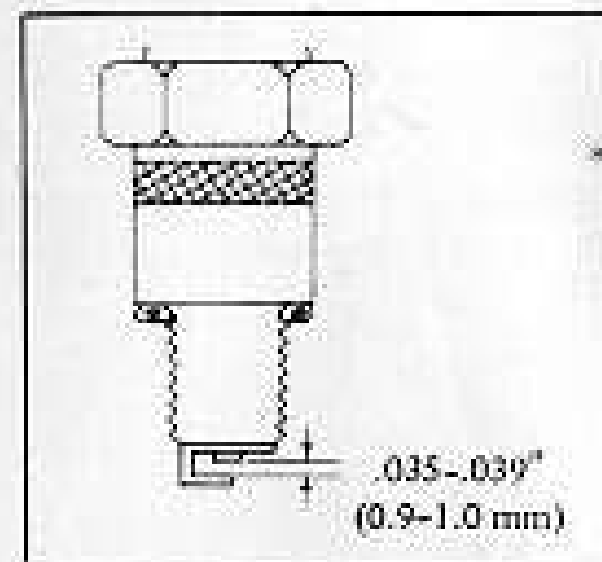

sary. The NGK B-8H plugs in particular can damage the engine if used for high speed riding. Note: If any spark plugs other than the three listed above are used, the replacement plugs absolutely **MUST** have the same: (1)thread pitch; (2)reach (threaded portion  $\frac{3}{8}$  inch or 19 mm long); and (3)diameter of threaded part ( $\frac{9}{16}$  inch or 14 mm).

If the plug reach (threaded portion) is too short, there may be too few threads to hold it in place, and it may blow out. In addition, carbon will build up causing overheating and prevent a new plug from being screwed fully into the hole.

If the reach is too long, carbon will build up around the threads, resulting in overheating and pre-ignition, and a hole may be burned into the top of the piston. The carbon collected on the plug threads will also make removing the spark plug very difficult.

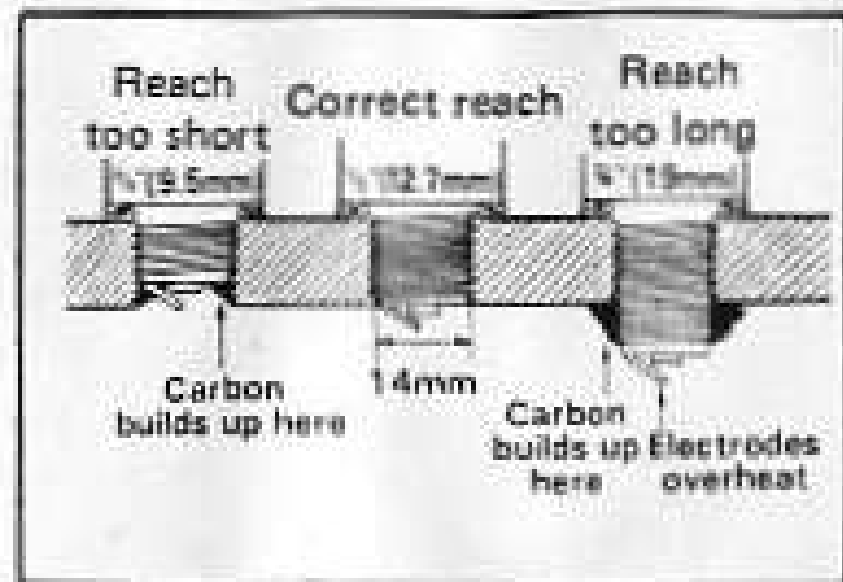

## 9. Air Cleaner

A clogged air cleaner restricts the engine's air intake, decreasing gas mileage and engine power, and causing the spark plug to foul.

The filter element must be cleaned at least every 2,000 miles (3,000 km). In dusty areas, the element should be cleaned every 500 miles (800 km) or less. After riding through rain or on muddy roads, the element should be cleaned immediately.

To remove the air cleaner for inspection and cleaning:

- ☆ Loosen the one large and three small clamps and pull off the air ducts.
- ☆ Unmount the left carburetor from the inlet pipe and move it aside.
- ☆ Remove the cleaner housing mounting bolt and pull out the housing and element together.

Wash the element in gasoline and dry it out with compressed air.

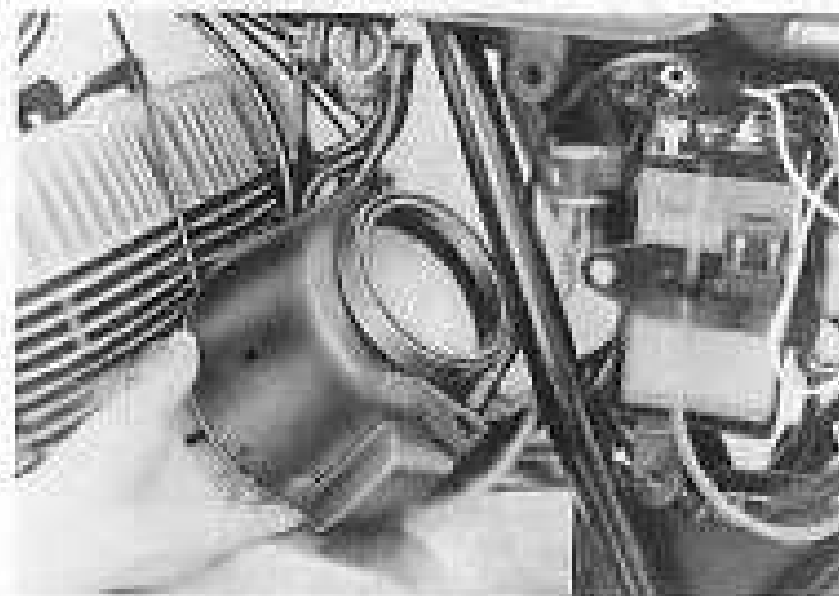
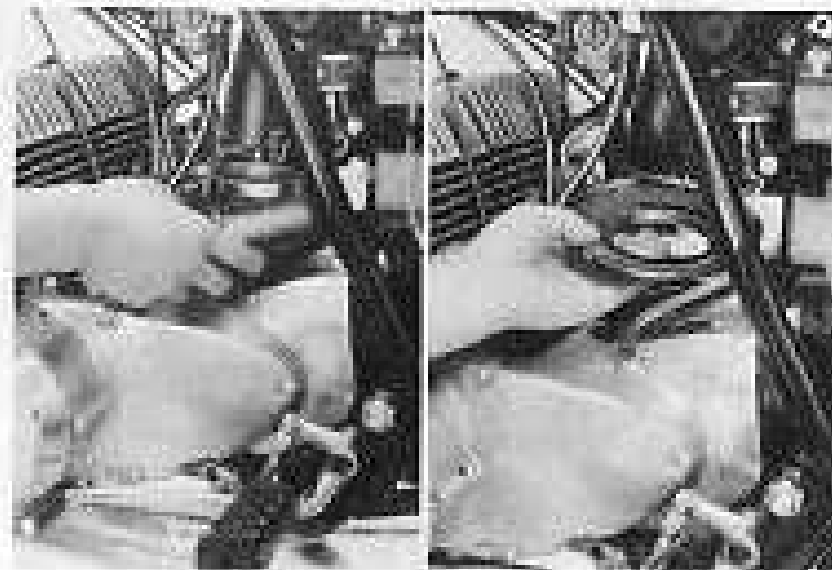

After cleaning, dampen it with a small amount of gasoline/oil mixture (about a 20:1 mixture of gasoline and SAE 30 motor oil).

Replace the element after 6,000 miles (10,000 km), after cleaning it 5 times, or if it is damaged.

**Caution:** A break in the element material, or damage to the sponge gasket will allow dirt and dust to pass through into the carburetors and eventually damage the engine. If any part of the element is damaged, it must be replaced.



## 10. Carburetor and Related Adjustments

### Starter cables

First turn the starter cable adjusting nut at the lower end of each starter cable so that the outer sleeve of the cable has less than 1/16 inch (1 mm) play.

Then adjust the starter lever for about 3/16~1/4 inch (4~6 mm) play measured at the tip of the lever.

### Throttle cables

Screw in each throttle stop screw (idle adjust screw) 3 or 4 turns until the throttle valves are fully closed. Using the throttle cable adjusting nut at the top of the carburetor, adjust all the play out of the outer sleeve of each cable.

Check throttle grip play and oil pump adjustment, and then adjust engine idle speed.

**Note:** After the idle adjustment is made, the throttle cables will have a small amount of play. This is correct, and should not be re-adjusted.

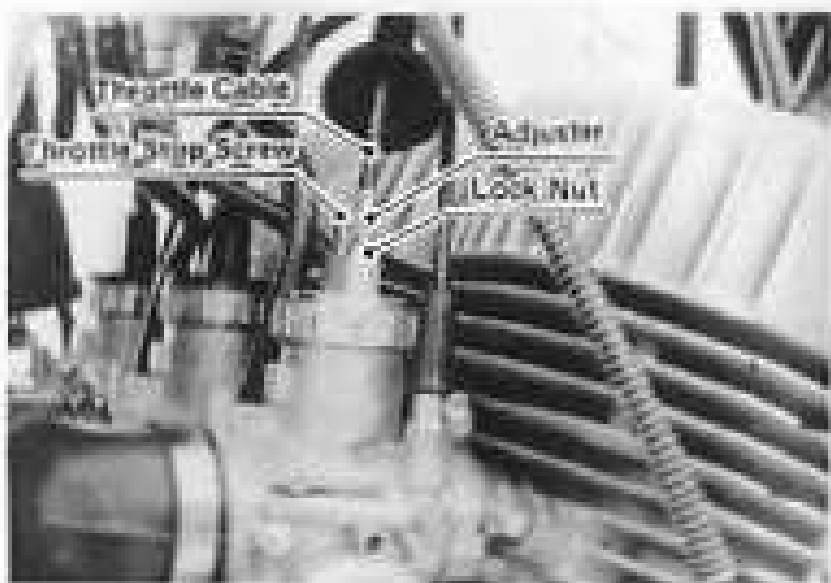
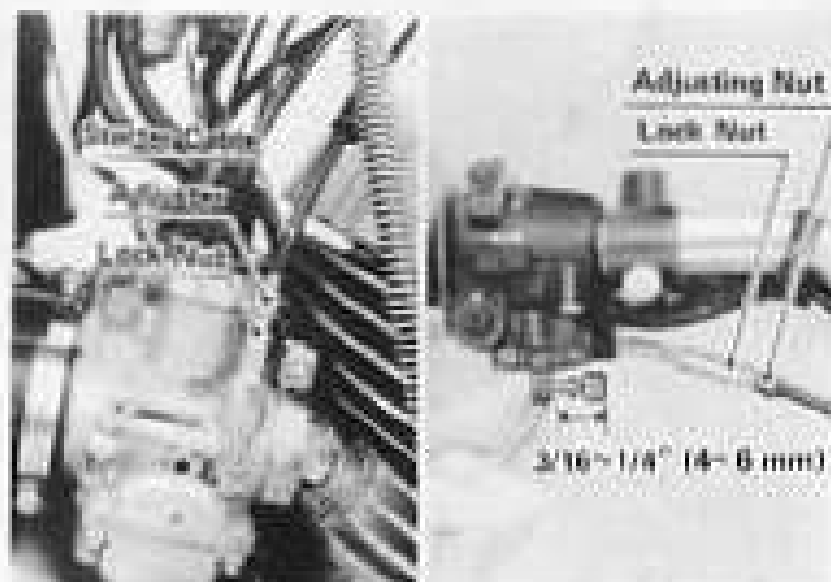

## Throttle grip play

With the handlebars pointing straight forward, adjust the throttle grip play with the adjusting nut on the control cable, so that there is 1/16~1/8 inch (2~3 mm) play in the outer sleeve of the cable.

## Oil pump adjustment

Due to stretching of the control wire and other factors, the oil pump lever sometimes gets out of adjustment and will not respond immediately to the opening of the throttle. When readjusting the carburetor, it is a good idea to check the oil pump adjustment, too.

Remove the right engine cover and see if the mark on the oil pump lever is aligned with the corresponding mark on the lever stopper with the throttle closed. If it is not, turn the cable adjuster to line up the two marks, and tighten the lock nut. Twist the throttle and check that the oil pump lever opens at the same time as the carburetor slides from the fully closed position. Check the tightness of all oil line fittings, and then replace the right engine cover.

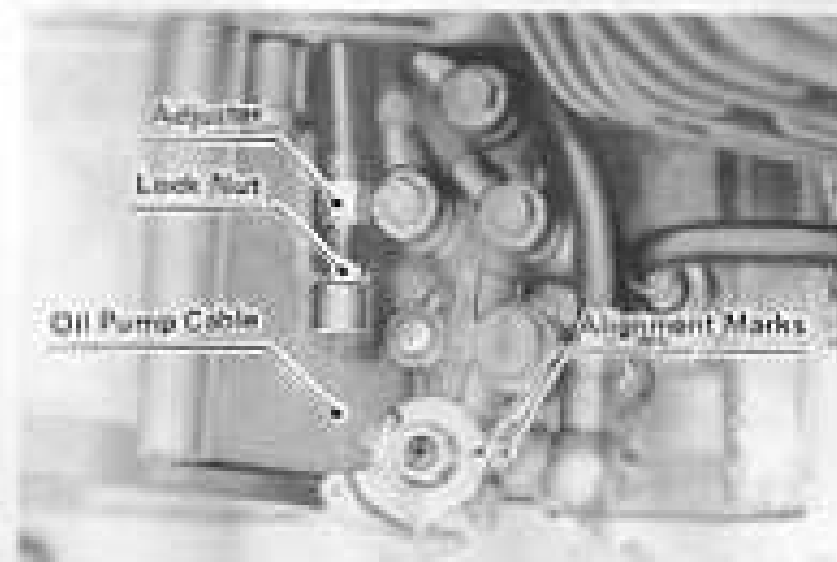
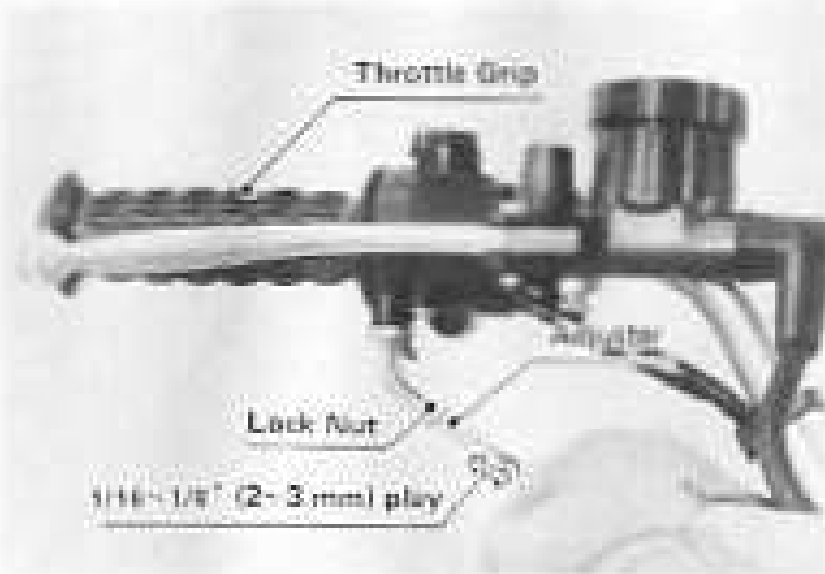



Careful adjustment of the oil pump is critical to engine performance and reliability. If the oil pump is improperly adjusted so that it lags behind the carburetors, the engine will not receive sufficient lubrication. This could lead to severe engine damage. If the oil pump is adjusted so that it opens before the carburetors, overlubrication will cause spark plug fouling, piston ring sticking, and rapid carbon buildup in the combustion chambers.

If there is any air or water in the oil lines, bleed them as follows:

- (1) Loosen the pump intake fitting until the air or water is drained, and tighten all oil pump fittings;
- (2) Push the pump lever fully open by hand while running the engine at idle speed until no air appears in the pump outlet pipes.

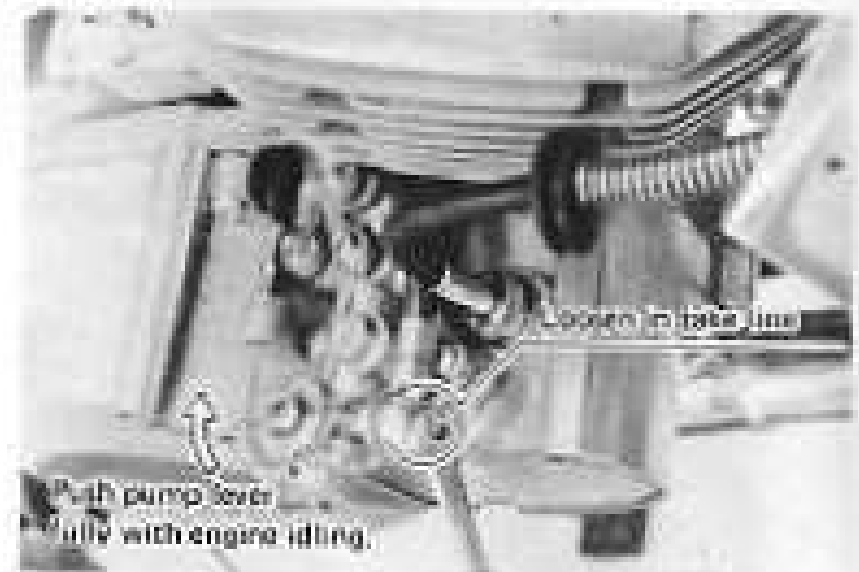

## Idle speed

First screw in the air screw fully – but not tightly – and then back it out 1½ turns. This sets the low speed mixture.

After first thoroughly warming up the engine turn the throttle stop screw and set engine idle speed to the lowest stable speed obtainable, normally between 1,200 and 1,400 r.p.m. Turning the screw out raises r.p.m. and increases throttle cable play, but don't re-adjust this play if it was correctly adjusted before.

With the engine idling, turn the handlebars back and forth. If handlebar movement changes idle speed, the throttle, oil pump or starter cable may be damaged, or the routing of the cable may be poor.

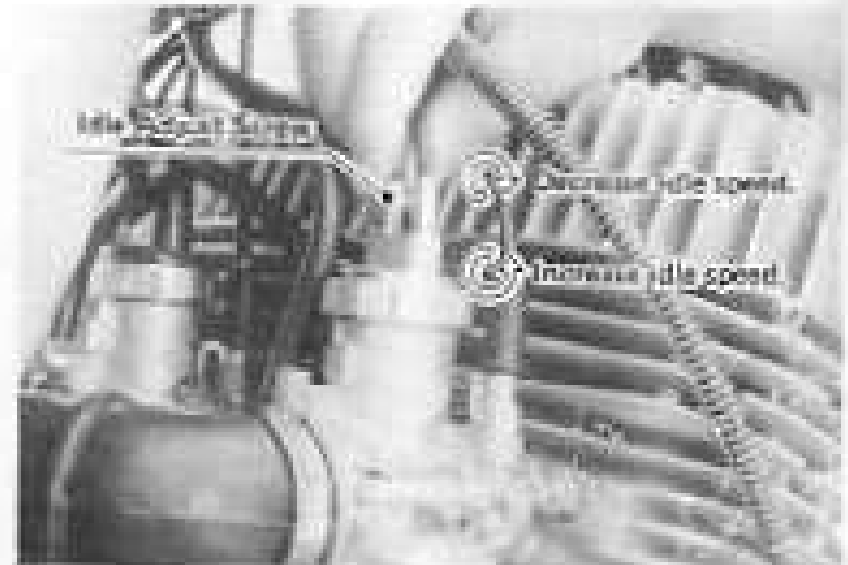
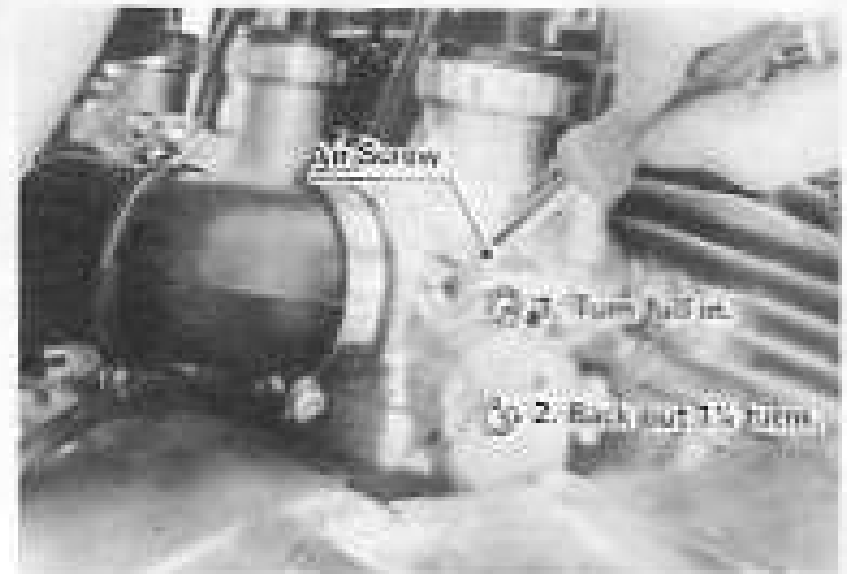

## 11. Ignition Timing

The H1 incorporates a new type of electronic CDI ignition. This is a highly improved system operating on the capacitor discharge principle. Automatic spark advance is electronically controlled, and complete ignition or starting failure is virtually eliminated by using three independent sealed ignition units.

Since there are no moving parts and no contact breakers to wear down, any adjustment is usually unnecessary. However, in case the engine is disassembled, or if the ignition signal generator coils are accidentally broken or knocked out of place, adjustment may be required.

### Gap adjustment

Before the timing itself can be accurately checked or adjusted, each of the three signal generator pickup coils must be set to .020 to .031 inch (0.5-0.8 mm) from the magnet projection on the rotor. Measure this gap with a feeler gauge and

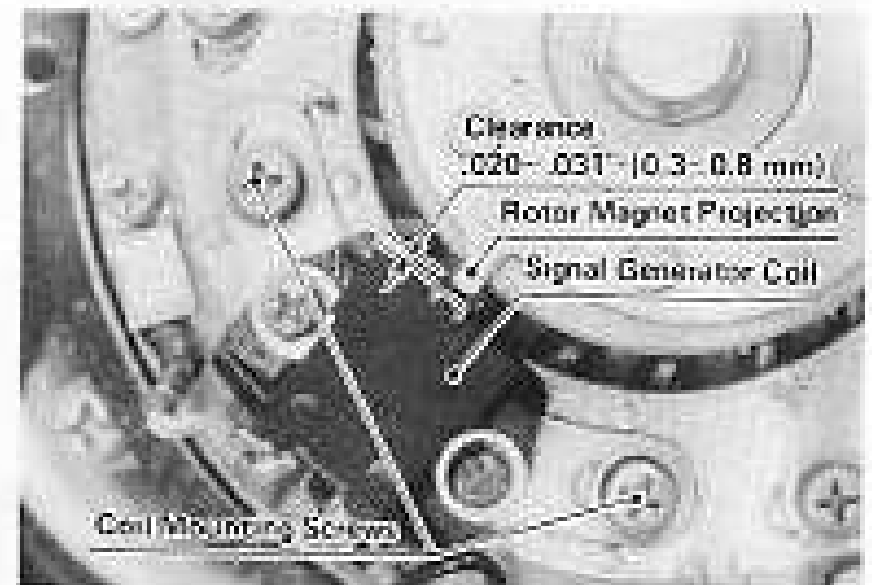
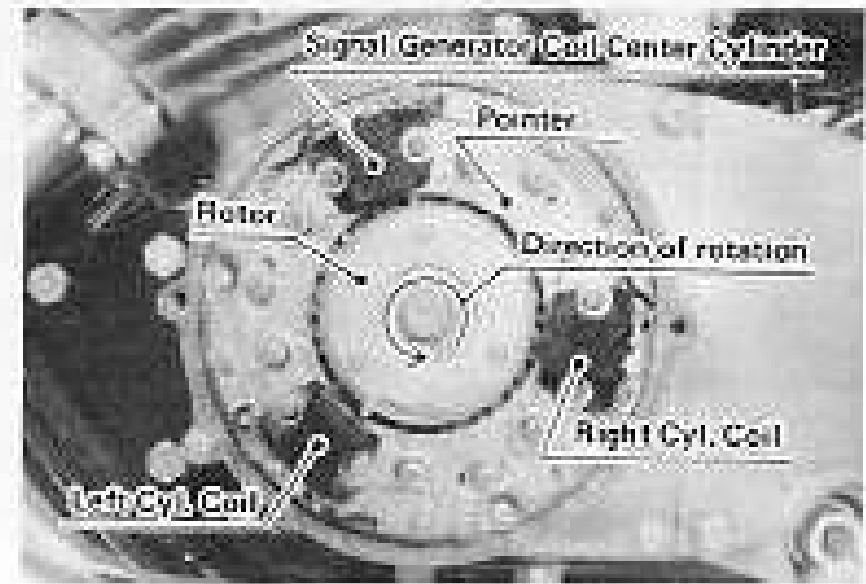

if it is incorrect, thoroughly loosen the two coil mounting screws and move the coil by hand.

**Caution:** Do not pry the pickup coil with a screwdriver or any other tool since this may break the coil housing.

### Partial timing adjustment

There are three sets of marks on the outside of the rotor: an L (Left) and an S mark for the left cylinder timing, R and S marks for the right cylinder, and C and S marks for the center. Check timing by alining the S mark, with the pointer and seeing if the trailing edge of the rotor magnet projection coincides with the timing mark on the top of the coil housing. If one of the coils is out of line, loosen the two coil base plate mounting screws and move that coil and base to the right or left, again taking care not to pry on the coil itself.



## Complete timing readjustment

It is recommended that this be performed by a Kawasaki Dealer, especially during the warranty period. If the essential tools are available, adjust timing as follows: (a) set coil gaps; (b) remove left cylinder spark plug and insert dial gauge; (c) set piston to .116 inch (2.94 mm) BTDC; (d) bend pointer to coincide with rotor L mark; (e) set timing as in "Partial timing adjustment" (f) use strobe to see if L, R and C marks coincide with pointer at 4,000 r.p.m. (g) readjust timing if necessary.



## 12. Battery

Ignition, lights and all other electrical equipment depend on the battery, so battery inspection and maintenance should never be neglected.

• Always keep the battery water level up above the low mark. When it gets low, add only distilled water, filling it to the upper level. Do not add sulphuric acid; the solution will become too strong and damage the battery.

• Do not let the plastic pipe on the side of the battery get folded or pinched, and route it away from the exhaust system, where it could be melted shut. This pipe lets out the gas that is produced inside the battery as it charges, and if the gas cannot escape through the pipe, it will break open the battery case. Route the pipe away from the chain since the battery gases will corrode and weaken the metal.

• Make certain that the battery connections are tight and that the correct polarity is observed. After the battery terminal clamps are tightened, a light coat of grease should be applied to the terminals to prevent corrosion.

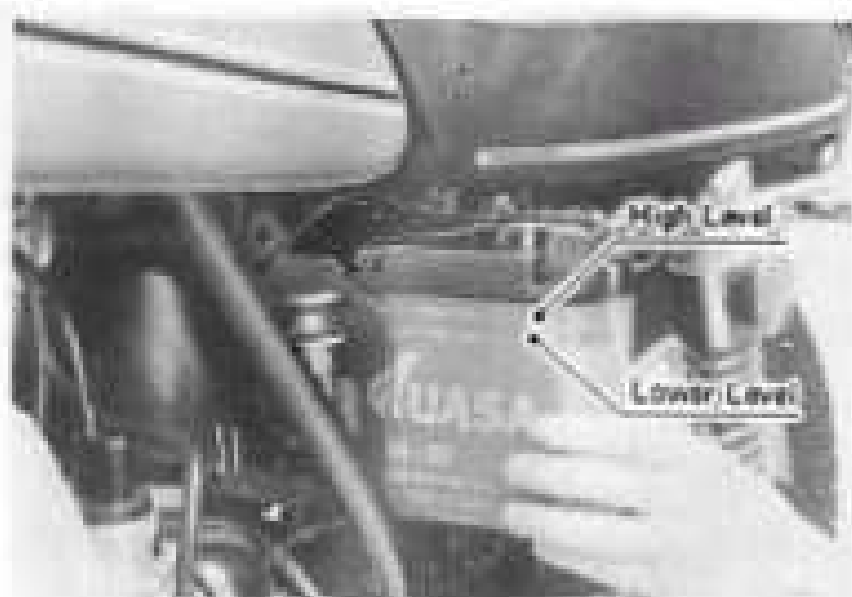

### 13. Mufflers

The mufflers have baffle tubes which can fill up with carbon and other exhaust by-products over an extended period of operation, resulting in a slight drop in performance.

To remove the baffle tube for cleaning, take out the bolt and pull the tube out with pliers.

Clean the baffle tube with a wire brush and by striking it gently, or by burning the carbon out.

The glass wool in the muffler further muffles exhaust noise. If it is especially dirty, remove some of the dirtiest part.

**Note:** Performance drops if the motorcycle is run without the baffle tube inside the muffler. Always run with the muffler fully assembled.

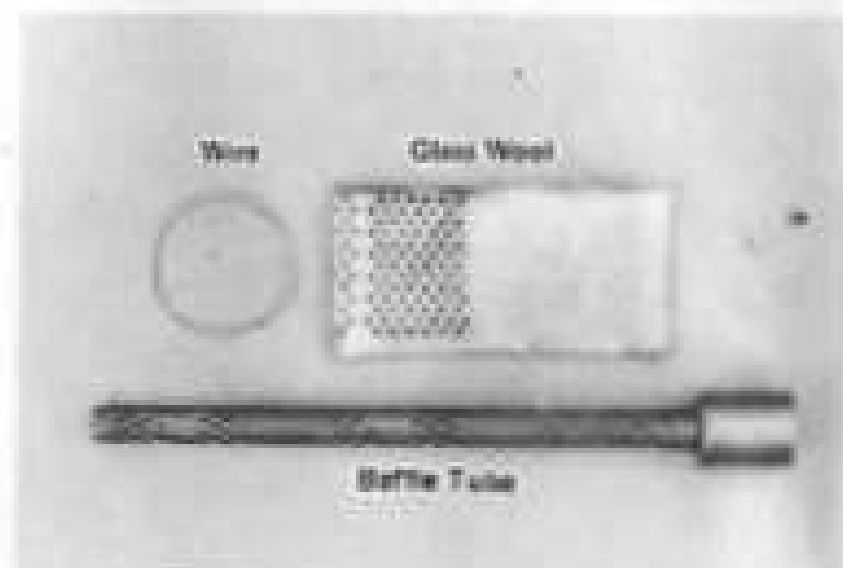
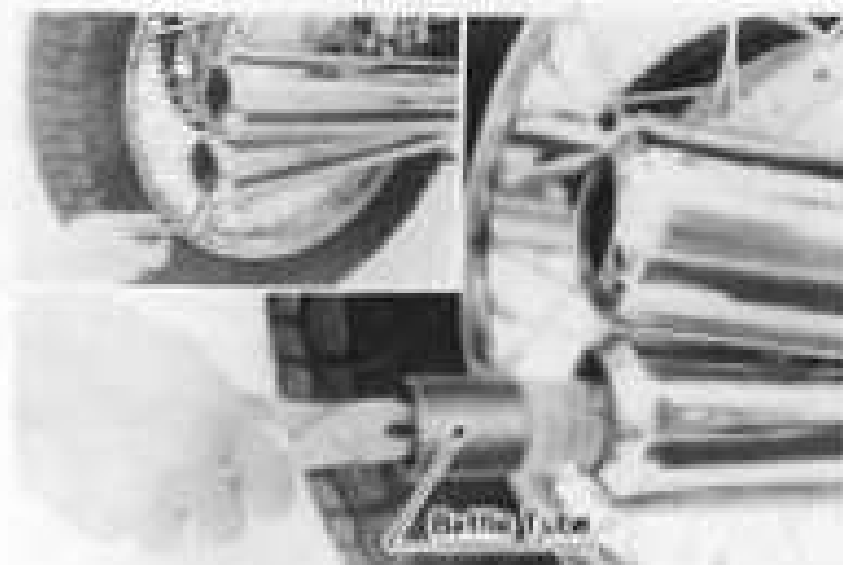

## 14. Cleaning

When the motorcycle becomes dirty, not only do the painted and plated surfaces deteriorate, but rust sets in on the nuts and bolts, and inspection and adjustment become difficult. For these reasons, and for the beauty of the machine, cleaning should be made a part of your regular maintenance.

### 1) Preparation for washing

Before washing, precautions must be taken to keep water off the following parts:

- ★Rear opening of the muffler ..... Cover with a plastic bag secured with rubber bands.
- ★Clutch and brake levers, hand grips ..... Cover with plastic bags.
- ★Ignition switch ..... Cover the keyhole with tape.
- ★Air cleaner intake..... Close up the opening with tape, or stuff in rags.  
(Be sure to remove these after washing.)

### 2) Where to be careful

Avoid spraying water with any great force near these places:

#### ★Brake drums

If water gets inside the brake drums, the brakes will not function until they are dried out. After washing, always test the brakes before taking the motorcycle out into traffic.



☆Under the gas tank

If too much water gets into the ignition coil or into the spark plug cap, the spark will jump through the water and be grounded out. When this happens, the motorcycle will not start and the affected parts must be wiped dry.

### 3) Washing

Using a brush and water, wash the tires, underside of the fenders, engine, etc. Wash the painted and chrome surfaces with water and a sponge or soft cloth.

Immediately after washing, remove the covers and start the engine to dry out any water which may have entered.

The motorcycle should always be lubricated after washing it, with special attention given to the chain and sprockets.

### 4) Waxing

A clean, well-polished Kawasaki Motorcycle is a handsome machine. But besides adding to its looks, a good coat of wax protects the paint and chrome, and makes it easy to wipe off collected road dust and dirt.

Apply the wax with a clean, soft cloth and polish it with a separate cloth.

## 15. Storage

When the motorcycle is to be stored for any length of time, such as during the winter season, it should be prepared for storage according to the following guide.

- ☆Clean the entire vehicle thoroughly.
- ☆Run the engine for about five minutes to warm the oil, and drain the transmission oil.
- ☆Empty the gasoline from the gas tank and from the carburetor. Sitting for a long period of time sours the gasoline, which then clogs the fuel tap and carburetor jet.

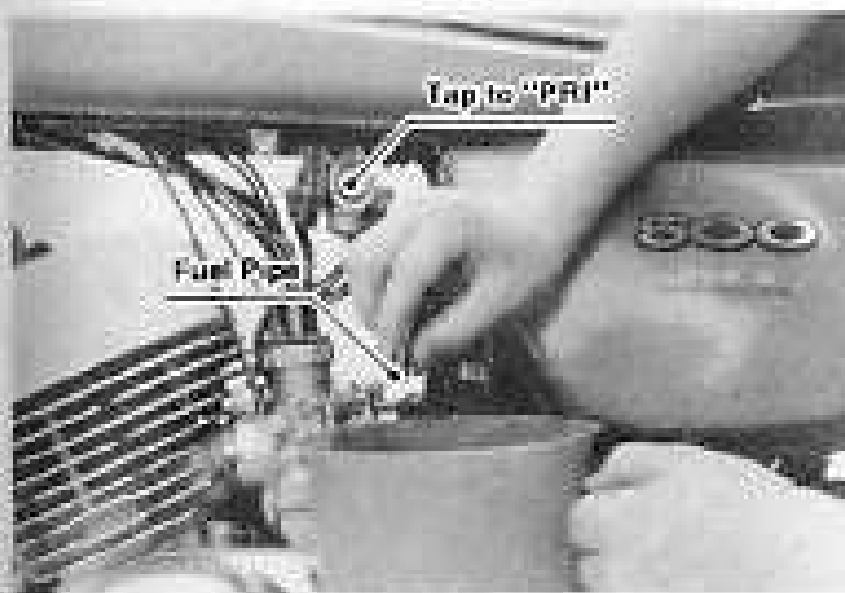

☆ Remove the spark plugs and put several drops of SAE 30 oil into each cylinder. Kick the engine over two or three times to coat the sides of the cylinders with oil, and reinsert the spark plugs to prevent dirt from entering the cylinders.

☆ Reduce tire pressure by about 20% and set the motorcycle up on its center stand. Put a board under the front wheel to keep dampness from the tire.

☆ Spray oil on all unpainted metal surfaces to prevent rusting. Avoid getting oil on rubber parts, or in the brakes.

☆ Remove the battery and store it where it will not be exposed to direct sunlight, moisture, or freezing temperatures. During storage, give it a slow charge (one ampere or less) about once a month.

☆ Cover the motorcycle to keep dust and dirt from collecting on it.



## 16. Lubrication

Appropriate lubrication not only lengthens the life of the vehicle, but by keeping it running smoothly and quietly, adds to riding enjoyment.

Using SAE 20 or 30 oil, lubricate the points shown in the photographs after washing the motorcycle, driving through rain, or whenever necessary. Grease the places indicated with regular cup grease at least every 6 months or 2,000 miles (3,000 km).

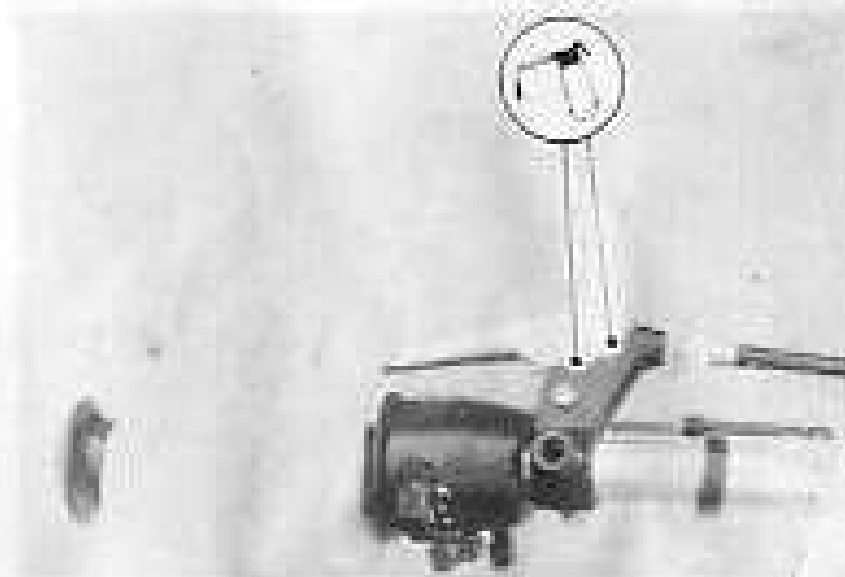
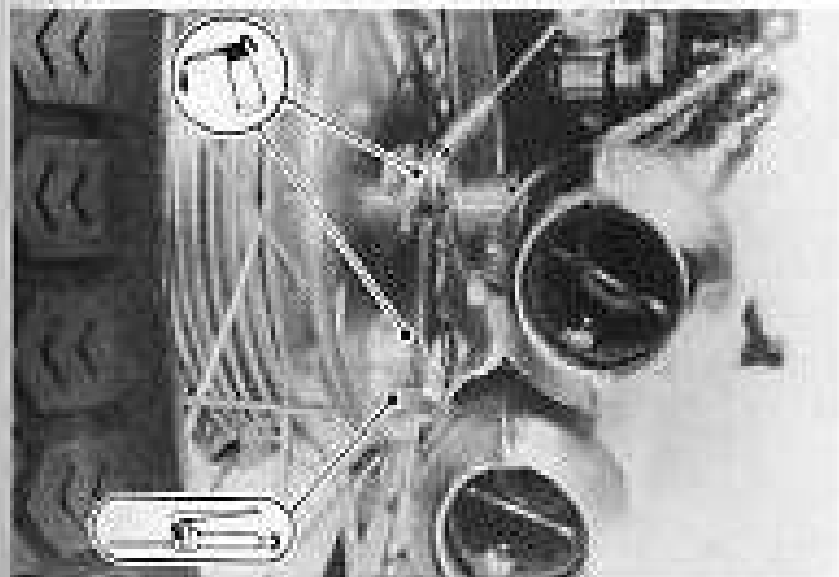
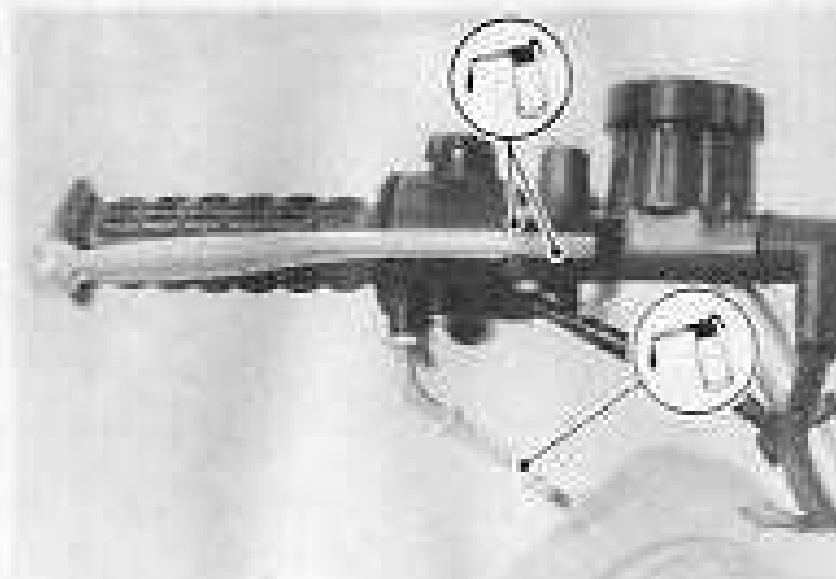

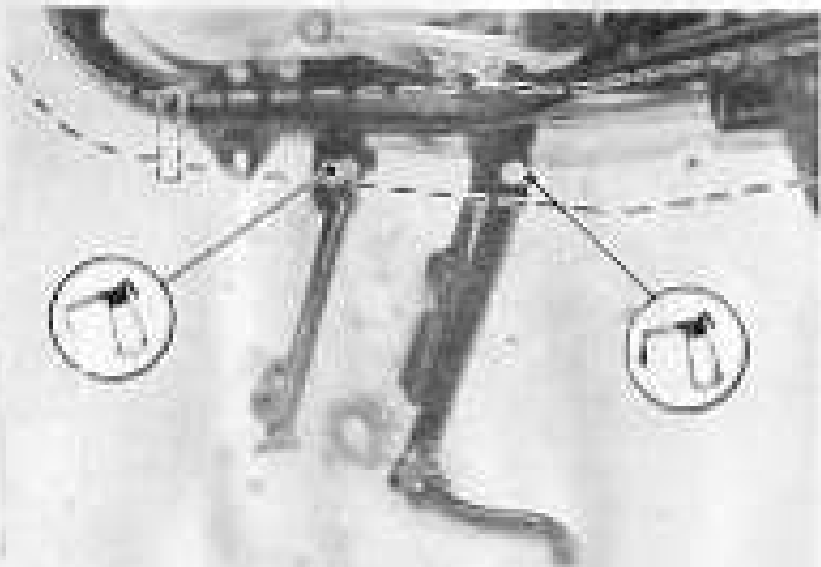
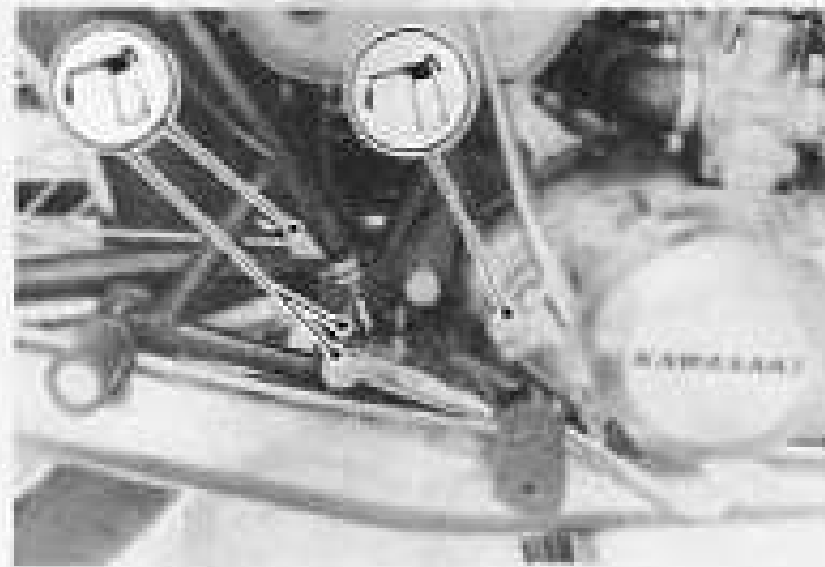

# TROUBLESHOOTING GUIDE

## Engine doesn't start

- ★No gasoline in tank
- ★Gasoline not reaching carburetors
  - ☆Fuel tap lever position incorrect
  - ☆Fuel tap obstructed or defective
- ★Flooded
  - ☆If the engine is flooded, kick it over with the throttle fully open to let more air in.
- ★Starter not working normally
  - ☆Starter cable play maladjusted
  - ☆Lever not returning
- ★Generator defective, or wire disconnected
- ★Ignition rectifier unit defective

## Engine stops

- ★No gasoline
- ★Fuel tap clogged or lever position wrong
- ★Gas tank cap air vent obstructed
- ★Generator defective or wire disconnected
- ★Ignition rectifier unit defective
- ★Overheated

- ☆No engine oil
- ☆Transmission oil low
- ☆Incorrect spark plugs
- ☆Carburetors adjusted too lean
- ☆Timing maladjusted
- ☆Carbon built up in combustion chamber

## No power

- ★Compression leakage
  - ☆Spark plug loose
  - ☆Head not sufficiently tight
- ★Clutch slipping
  - ☆Clutch maladjusted or worn
- ★Timing maladjusted
- ★One plug not firing
  - ☆Carburetor or fuel pipe clogged
  - ☆Spark plug defective
  - ☆Signal generator coil defective
  - ☆Ignition unit defective
  - ☆Wire broken or disconnected
  - ☆Ignition rectifier unit defective
- ★Carbon built up in cylinder exhaust ports or mufflers

## DAILY CHECKS

Front Brake .....	Brake lever play less than 3/16 in. (5 mm); fluid up to level line; no damage to brake line or fittings.
Rear Brake .....	Brake pedal play ¾ to 1¼ inch (20–30 mm)
Clutch .....	Clutch lever play about 1/16 to 1/8 inch (2–3 mm)
Oil Tank .....	Oil level well above bottom of inspection window
Transmission Oil .....	Above low level on dip stick
Front Tire .....	Air pressure 26 psi (1.8 kg/cm <sup>2</sup> )
Rear Tire .....	Air pressure 31 psi (2.2 kg/cm <sup>2</sup> )
Spokes .....	Tighten any loose spokes.
Chain .....	Oil as necessary
Battery .....	Battery water above low level mark
Electrical Equipment .....	Check that the headlight, tail light, brake light, turn
Chrome-plated Parts .....	First clean off, and then wipe with an oily cloth to prevent rusting.