



KH500-A8



MOTORCYCLE
OWNER'S MANUAL

NOTICE

THIS PRODUCT HAS BEEN MANUFACTURED FOR USE IN A REASONABLE AND PRUDENT MANNER BY A QUALIFIED OPERATOR AND AS A VEHICLE ONLY.

FOREWORD

We wish to thank you for choosing this fine Kawasaki Motorcycle. It is the end product of Kawasaki's advanced engineering, exhaustive testing, and continuous striving for superior reliability, safety and performance. By giving your motorcycle the proper care and maintenance outlined in this manual, you will ensure it a long, trouble-free life.

Before starting to ride your motorcycle, please read this manual thoroughly in order to know your motorcycle's capabilities, its limitations, and above all, how to operate it safely.

In addition to this owner's manual, for those who would like more detailed information on their Kawasaki Motorcycle, or for those with the necessary technical knowledge and equipment for major adjustment and repair, a Shop Manual is now available for purchase from any Kawasaki Dealer.

Due to improvements in design and performance during production, in some cases there may be minor discrepancies between the actual vehicle and the illustrations and text in this manual.

KAWASAKI HEAVY INDUSTRIES, LTD.
ENGINE AND MOTORCYCLE GROUP

***** TABLE OF CONTENTS *****

Specifications	4	Engine Stop Switch	25
Consumer Information	7	Choke Lever	26
Serial Number Locations	10	Fuel Tap	26
Location of Parts	11	Fuel Tank Cap	27
Location of Caution Labels	14	Steering Lock	27
General Information	15	Stands	28
Brake Lever and Pedal	15	Seat Lock	28
Clutch Lever.....	16	Helmet Hooks	29
Shift Pedal	17	Document Container	29
Throttle Grip	18	Fuse Box	30
Kick Starter Pedal	19	Tool Kit	30
Speedometer and Tachometer	19	Fuel and Oil	32
Indicator Lights	20	Fuel	33
Key.....	22	Engine Oil	33
Ignition Switch	22	Transmission Oil	33
Headlight Switch	23	Braking In	35
Dimmer Switch	23	How to Ride the Motorcycle	36
Horn Button	24	Starting the Engine	36
Horn and Passing Button	24	Moving Off	37
Turn Signal Switch	25	Shifting Gears	37

Braking	38	Rear Shock Absorber Inspection and Adjustment	61
Stopping the Engine	38	Air Cleaner Maintenance	62
Stopping the Motorcycle in an Emergency	39	Headlight Beam Adjustment	64
Safe Riding Technique	40	Throttle Grip Play Adjustment	64
Daily Safety Checks	42	Ignition Timing	66
Additional Considerations for High Speed Operation	44	Battery Maintenance	66
Maintenance and Adjustment	45	Spark Plug Maintenance	67
Periodic Maintenance Chart	46	Idle Speed Adjustment	68
Front Brake Adjustment	48	Carburetor Cable Adjustment	69
Rear Brake Adjustment	50	Oil Pump Cable Adjustment	70
Brake Light Switch Adjustment	51	Choke Cable Adjustment	70
Clutch Adjustment	52	Fuel Tap Cleaning	71
Wheel Inspection	53	Decarbonization	72
Steering Inspection	56	Lubrication	73
Drive Chain Inspection and Adjustment	57	Bolt and Nut Tightening	75
Drive Chain Lubrication	59	Cleaning	77
Front Fork Inspection and Maintenance	60	Storage	78
		Troubleshooting Guide	80
		Wiring Diagram	inside back cover

SPECIFICATIONS

PERFORMANCE

Maximum Horsepower	52 HP @7,000 rpm
Maximum Torque	5.4 kg-m (39.1 ft-lb) @6,500 rpm
Climbing Ability	27°
Minimum Turning Radius	2.4 m (94.5 in)
Braking Distance	12.5 m @50 kph (41 ft @31 mph)

DIMENSIONS

Overall Length	2,085 mm (82.1 in)
Overall Width	835 mm (32.9 in)
Overall Height	1,140 mm (44.9 in)
Wheelbase	1,410 mm (55.5 in)
Road Clearance	145 mm (5.7 in)
Dry Weight	192 kg (423 lb)

ENGINE

Type	2-stroke, 3 cylinder, piston valve
Displacement	498 cc (30.38 cu in)
Bore x Stroke	60.0 x 58.8 mm (2.36 x 2.31 in)
Compression Ratio	6.8:1
Ignition System	Electronic CDI

Ignition Timing	23° BTDC @4,000 rpm
Starting	Kick
Carburetors	Mikuni VM28SC x 3
Spark Plug	NGK B9HS
Lubrication	Injectolube (oil injection)
Engine Oil	2-stroke oil

TRANSMISSION

Type	5-speed, constant-mesh, return shift
Clutch	Wet, multi-disc
Primary Reduction Ratio	2.41 (66/27)
Final Reduction Ratio	3.00 (45/15)
Overall Drive Ratio	5.83
Gear Ratio: 1st	2.20 (23/15)
2nd	1.40 (28/20)
3rd	1.09 (25/23)
4th	0.92 (23/25)
5th	0.81 (21/26)
Transmission Oil	SAE 10W30 or 10W40 1.2 ℓ (1.3 US qt)

FRAME

Castor		63°
Trail		108 mm (4.3 in)
Tire Size:	Front	3.25H-19 4PR
	Rear	4.00H-18 4PR
Fuel Tank Capacity		18 ℓ (4.2 US gal)
Engine Oil Capacity (oil tank)		2.3 ℓ (2.4 US qt)

ELECTRICAL EQUIPMENT

Battery		12V 9AH
Headlight		12V 50/35W
Tail/Brake Light		12V 8/27W (3/32 CP)
Turn Signal Lights		12V 23W
Meter Lights		12V 3W
Neutral Indicator Light		12V 3W
Turn Signal Indicator Light		12V 3W
High Beam Indicator Light		12V 1.5W
Brake Light Failure Indicator Light		12V 3W
Fuses		20A (Main)
		10A (Head)
		10A (Tail)

Specifications subject to change without notice.

Vehicle Minimum Stopping Distance on Dry Pavement

These figures indicate braking performance that can be met or exceeded by the vehicle to which they apply, without locking the wheels, under different conditions of loading. The information presented represents results obtainable by skilled drivers under controlled road and vehicle conditions, and the information may not be correct under other conditions.

Description of vehicle to which this table applies: Model KH500-A8

A. Fully Operational Service Brake

Load: Light

143

Maximum

149

0 50 100 150 200

Stopping distance in feet from 60 mph.

Manufacturer: Kawasaki Heavy Industries, Ltd.

Acceleration and Passing Ability

These figures indicate passing times and distances that can be met or exceeded by the vehicle to which they apply, in the situations diagrammed on the next page. The low-speed pass assumes an initial speed of 20 mph and a limiting speed of 35 mph.

The high speed pass assumes an initial speed of 50 mph and a limiting speed of 80 mph.

Note: The information presented represents results obtainable by skilled drivers under controlled road and vehicle conditions, and the information may not be correct under other conditions.

Description of vehicle to which this table applies. Model KH500-AB

Summary Table:

Low-speed pass	423 feet	9.9 seconds
High-speed pass	990 feet	10.0 seconds

Graphic Determination of Passing Time and Distance

LOW-SPEED PASS:

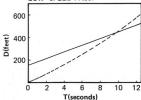

HIGH-SPEED PASS:

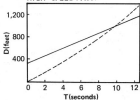

LOW-SPEED



HIGH-SPEED



SERIAL NUMBER LOCATIONS

The frame and engine serial numbers are used to register the motorcycle. They are the only means of identifying your particular machine from others of the same model type. These serial numbers may be needed by your dealer when ordering parts. In the event of theft, the investigating authorities will require both numbers as well as the model type and any peculiar features of your machine that can help them locate it.



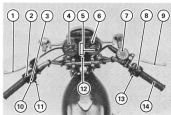

1. Clutch Lever
2. Dimmer Switch
3. Turn Signal Switch
4. Speedometer
5. Indicator Lights
6. Tachometer

7. Brake Fluid Reservoir
8. Engine Stop Switch
9. Front Brake Lever
10. Horn Button (US model)
Horn and Passing Button
(European model)

11. Choke Lever
12. Ignition Switch
13. Headlight Switch
14. Throttle Grip

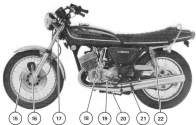

- 15. Disc
- 16. Caliper
- 17. Steering Lock

- 18. Fuel Tap
- 19. Shift Pedal
- 20. Side Stand

- 21. Center Stand
- 22. Rear Shock Absorber

12 LOCATION OF PARTS



23, Seat Lock
24, Engine Oil Tank

25, Rear Brake Light Switch
26, Kick Starter Pedal

27, Rear Brake Pedal
28, Horn

LOCATION OF CAUTION LABELS

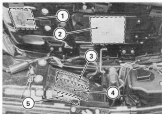

1. Battery Vent Hose Routing Label
2. Daily Safety Checks Label
3. Tire and Load Data Label
(not on European model)
4. Important Drive Chain Information Label

5. Brake Fluid Label (not on US model)
6. Fuse Box Label
7. Battery Poison/Danger Label
(only on US model)
8. Brake Fluid (only on US model)

Brake Lever and Pedal

The lever on the right side of the handlebar operates the front brake, and the foot pedal on the right side operates the rear brake.

When stopping, always apply both brakes at the same time if stopping quickly; normally the front brake should be applied a little more than the rear brake. Should braking become necessary when turning a corner, apply only the rear brake in order to minimize the danger of skidding.

The front brake is a hydraulic disc brake. The reservoir for it must be kept filled with disc brake fluid or the brake will not operate.

See Pg. 48 for a list of recommended brake fluids and for other important brake information.

When either the front or rear brake is applied, the tail brake light goes on. The front brake employs a pressure switch which requires no adjustment, but the rear brake light switch may need adjustment from time to time.

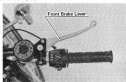

On the rear brake panel is a brake lining wear indicator. If the indicator does not point within the **USABLE RANGE** when the brake is fully applied, the brake shoe linings have worn past the service limit. When this happens, the brake shoes must be replaced and the drum and other brake parts examined.

Note: So that it remains in its proper position, do not remove the brake lining wear indicator.

Clutch Lever

The clutch lever on the left side of the handlebar disengages the clutch when pulled in.

The clutch must be left engaged – that is, don't pull in the lever – when starting the engine.

If the clutch lever develops too much travel before it will disengage the clutch, take up the excess play by loosening the lock nut, backing out the adjuster, and then re-tightening the lock nut. When this adjustment will no longer take up lever play, readjust the clutch completely (Pg. 52).

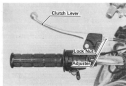

Shift Pedal

The transmission is a 5-speed, return-shift type with neutral halfway between 1st and 2nd gears.

A "return shift" means that to go back to 1st gear from a higher gear, you must return the way you came, shifting back through the gears one by one.

To shift to the next higher gear, disengage the clutch (i.e., pull the clutch lever in), lift the shift pedal up as far as it will go, and then release the clutch lever and shift pedal. To shift to the next lower gear, disengage the clutch, push the shift pedal down as far as it will go, and then release the clutch lever and shift pedal. If the engine is stopped, releasing the clutch lever and rolling the motorcycle slightly while shifting will help shifting back to neutral.

When the transmission is in neutral, the green neutral indicator light will be lit.



Note: Make it a point when shifting to lift up or push down the shift pedal fully. If shifting is done carelessly, the transmission may jump out of gear, causing over-rev damage to the engine.

Throttle Grip

The right handlebar grip controls the throttle. Viewed from the right grip end, twisting it counterclockwise opens the throttle, which raises engine speed; twisting it clockwise closes the throttle, which lowers engine speed. Releasing it allows spring tension to return it to the closed position. The throttle grip should be adjusted to give it a sufficient but not excessive amount of play (Pg. 64).

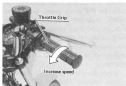

Kick Starter Pedal

The kick starter pedal is located at the right side of the engine.

Fold up the right rear footrest, and with your instep on the kick starter pedal and kick starter pedal play taken up, throw your weight down sharply on the pedal to start the engine. **CAUTION:** •Before starting the engine, check the neutral indicator light to make sure the transmission is in neutral.

•Be sure that the kick starter pedal is up before moving off.



Speedometer and Tachometer

The speedometer shows the speed of the vehicle. In the lower part of the speedometer face is the trip meter, which shows the distance traveled since it was last reset to zero. The trip meter can be reset to zero by turning the reset knob counterclockwise. In the upper part of



the speedometer face is the odometer. The odometer shows the total distance that the vehicle has been ridden.

The tachometer shows the engine speed in revolutions per minute (rpm). On the right side of the tachometer face is a portion called the "red zone". Engine rpm in the red zone is above maximum recommended engine speed and is also above the range for good performance. Engine rpm should not be allowed to enter the red zone, as this will over-stress the engine and may cause serious engine damage.

Indicator Lights

There are three indicator lights on the switch panel and one indicator light in the tachometer.

1. Turn Signal Indicator Light
2. Neutral Indicator Light
3. High Beam Indicator Light
4. Brake Light Failure Indicator Light



TURN	When the turn signal switch is turned on, the orange indicator light flashes on and off.
NEUTRAL	When the gears are in neutral, the green indicator light is lit.
HIGH BEAM	When the headlight is on high beam, the blue indicator light is lit.
STOP LAMP	<p>This indicator light, located on the lower part of the tachometer face, is used to detect brake light failure.</p> <p>If the brake light is functioning properly, the brake light failure indicator light goes on whenever one or both brakes are applied, and goes off whenever the brake or brakes are released.</p> <p>If the brake light is not functioning properly, the light will still go on whenever one or both brakes are applied; however, when neither brake is applied, the light will flash on and off indicating that the brake light circuit or the brake light itself is faulty.</p> <p>If the indicator light does not go on when a brake is applied, one of the brake switches, the indicator light switch inside the left side cover, or the indicator light itself is not functioning properly, or the ground circuit is interrupted.</p>

Key

With this motorcycle the same key is used for the ignition switch, the steering lock, the seat lock, and the fuel tank cap.

Ignition Switch

This is a 3 positions, key-operated switch. The key can be removed from the switch when it is in the OFF or PARK position.

Note: With the Canada model for greater safety, this motorcycle is designed so that the lights are on whenever the ignition switch is in the ON position. To avoid battery discharge, always start the engine immediately after turning the ignition switch to ON.

OFF	Engine off. All electrical circuits off. Key can be removed.
ON	Engine on. All electrical equipment can be used. Head and tail lights on. Key cannot be removed.
PARK	Engine off. Tail light on. All other electrical circuits out off, Key can be removed.



Headlight Switch

The headlight switch has two positions: **OFF** and **ON** on US model, and has three positions: **OFF**, **PO** and **ON** on European model.

OFF	The headlight is off with the switch in the OFF position.
PO	The city light, tail light and meter light come on if the switch is pushed to the PO position with the ignition switch in the ON position.
ON	The headlight, city light, tail light and meter light come on if the switch is pushed forward to the ON position with the ignition switch in the ON position.

Dimmer Switch

High or low beam can be selected with the dimmer switch. When the headlight is on high beam, a blue indicator light in the switch panel lights.

HI High Beam , LO Low Beam

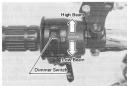
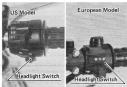

Horn Button

The horn is operated with the horn button located on the left side of the handlebar.

If the horn does not operate properly, check that the battery is good, and that the horn is mounted securely with nothing touching it. If the horn itself is at fault, it should be adjusted, repaired or replaced immediately.

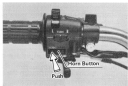

Horn and Passing Button (European Model)

The right side position of the horn and passing button is spring loaded, and can be used to turn on the passing beam whether the headlight is turned on or not.

By pushing the horn and passing button to **PASS** the headlight high beam (passing beam) comes on to signal the driver of the vehicle ahead that you are about to pass him. The passing light shuts off as soon as the button is released.

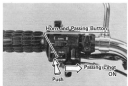

Turn Signal Switch

The turn signals are operated by the turn signal switch located on the left side of the handlebar.

When the switch is operated, the turn signal indicator light flashes on and off together with the turn signals.

L.....Left R.....Right



Engine Stop Switch

In addition to the ignition switch, the engine stop switch must be in the RUN position for the motorcycle to operate.

The engine stop switch is for emergency use. If some emergency requires stopping the engine suddenly, flick the engine stop switch to either of the OFF positions.

Note: Although the engine stop switch stops the engine, it does not turn off all the electrical circuits. Ordinarily, the ignition switch should be used to stop the engine.

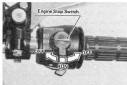

Choke Lever

The choke lever on the left side of the handlebar provides a rich mixture for cold starting conditions.

Keep it pushed in until the engine is warm, and then release it.

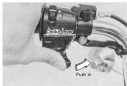

Fuel Tap

The fuel tap is an automatic type which shuts off the fuel supply when the engine is stopped.

In the ON position, the tap allows gasoline flow until a 2.0 liters (1/2 US gal) reserve remains. By turning tap to RES (reserve) the remaining gasoline can be used until the tank is empty.

The PRI (prime) position bypasses the automatic control and is useful for priming the engine after running out of gas, or for completely draining the tank.

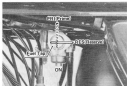

Fuel Tank Cap

To open the fuel tank cap: insert the ignition switch key into the cap, turn the key to the right, and open the cap. The fuel tank cap is locked when pushed back into place.



Steering Lock

To help prevent theft, the handlebar can be locked in either the full left or full right position.

Turn the handlebar fully to the left or right, insert the ignition key into the steering lock, turn the key $\frac{1}{2}$ turn to the left, and remove it.
CAUTION: •When using the side stand, have the handlebar turned to the left.
•Unlock the steering before starting the engine.



Stands

The motorcycle is equipped with two stands, a center stand and a side stand.

Whenever the side stand is used, make it a firm practice to kick the stand fully up before sitting on the motorcycle. Forgetting and leaving the side stand down while riding could cause an accident.

CAUTION: When using the side stand, have the handlebar turned to the left.

To set the motorcycle up on the center stand, step down firmly on the stand and then lift the motorcycle up and to the rear using the chrome bar as a handhold. Don't pull up on the seat to lift it as this will only damage the seat.

Seat Lock

The seat can be unlocked using the ignition key, and then swung open for checking the wiring, adding oil, securing a helmet to the motorcycle, or gaining access to the tools.

Pushing the seat back into place locks it.



Helmet Hooks

The rider's helmets can be secured to the motorcycle using the helmet hooks located under the seat.



Document Container

A receptacle for the owner's manual and any papers or documents that should be kept with the motorcycle, is provided on the bottom of the seat.



Fuse Box

The fuse box is located behind the left side cover, and it contains three fuses and two spare fuses. If the fuse blows during operation, inspect the electrical system to determine the cause, and then replace the fuse.

CAUTION: •Do not use any substitute for the standard fuse.

•Replace the fuse with correct capacity specified in the box for each circuit.



Tool Kit

The tool kit is located in the tool compartment above the rear fender. The minor adjustments and replacement of parts explained in this manual can be made with these tools.



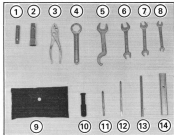

Tool Kit

The tool kit is located in the tool compartment above the rear fender. The minor adjustments and replacement of parts explained in this manual can be made with these tools.



1. Socket 10 mm
2. Spark Plug Wrench
17 x 21 mm
3. Pliers
4. Axle Wrench 27 mm
5. Hook Wrench and
22 mm Open End
Wrench
6. Open End Wrench
14 x 17 mm
7. Open End Wrench
12 x 13 mm
8. Open End Wrench
8 x 10 mm
9. Tool Case
10. Screwdriver Grip
11. Phillips Bit
12. Phillips and Slot
Combination Bit
13. Lever
14. Axle Wrench Extender

FUEL AND OIL

Fuel	Engine Oil	Transmission Oil
 <p data-bbox="142 464 423 495">Non-leaded gasoline</p>	 <p data-bbox="554 464 879 570">A 2-stroke engine oil which is recommended for air-cooled engines.</p>	 <p data-bbox="1064 464 1205 495"><u>Motor oil</u></p> <p data-bbox="1011 519 1263 547">Summer: SAE 30</p> <p data-bbox="1035 560 1263 588">Winter: SAE 20</p> <p data-bbox="976 601 1326 664">All seasons: SAE 10W30 or 10W40</p>
<p data-bbox="132 695 438 764">Entire capacity: 16 liters (4.2 US gal.)</p> <hr/> <p data-bbox="132 795 394 865">Reserve capacity: 2 liters (½ US gal.)</p>	<p data-bbox="569 767 870 798">2.3 liters (2.4 US qt.)</p>	<p data-bbox="991 767 1292 798">1.2 liters (1.3 US qt.)</p>

Fuel

The Kawasaki Injectolube system is used in this motorcycle. This system eliminates the necessity of the owner himself mixing in oil with the gasoline, so use only non-leaded gasoline in the fuel tank.

CAUTION: •Never fill the tank completely to the top! As the gasoline expands in a warm tank, it may overflow from the vents in the tank cap.

•Always put in gasoline with the ignition key turned off, and the motorcycle away from any source of sparks.

Engine Oil

Do not use ordinary motor oil, transmission oil, or an inferior grade of oil as a replacement for the proper oil. The use of improper oil will lead to engine trouble.

Adding oil

On the side of the oil tank there is a window for checking the oil level. 1.5 liter (1.6 US-qt) of oil should be added when the level drops to the center of this window. Since mixing different brands of oil deteriorates the lubricative properties of the oil, always add oil only of the same brand as that already in the tank.

CAUTION: Never let the oil tank run completely dry or severe engine damage will result.



Transmission Oil

1) Oil Level

Check the oil level with the dipstick on the filler hole plug. Remove the dipstick, and wipe off any oil on the end. Position the vehicle off its side stand so that it is standing fully perpendicular to the ground, insert the dipstick screwing it all the way in, and then remove it. Oil should be above the lower and below the upper dipstick marks.

2) Oil Change

After the first 800 km (500 mi) oil change, change the oil every 5,000 km (3,000 mi).

To change the oil:

- Warm up the engine thoroughly so that the oil will pick up any sediment and drain easily.
- Stop the engine, and remove the drain plug.
- Replace the plug and fill the transmission with 1.2 liters (1.3 US qt) of motor oil.



BREAKING IN

The first 1,600 km (1,000 mi) that the motorcycle is ridden is designated as the break-in period. If the motorcycle is not used carefully during this period, you may very well end up with a "broken down" instead of a "broken in" motorcycle after a few thousand kilometers.

The following rules should be observed during the break-in period.

- Maximum engine rpm during the break-in period

Distance traveled	Maximum engine rpm
0 ~ 800 km (0 ~ 500 mi)	4,000 rpm
800 ~ 1,600 km (500 ~ 1,000 mi)	6,000 rpm

- Do not start moving or race the engine immediately after starting it, even if the engine is already warm. Run the engine for two or three minutes at 1,000 ~ 1,500 rpm to give the oil a chance to work up into all the engine parts.
- Do not race the engine while the gears are in neutral.
- The slow riding necessary during the break-in period may cause carbon to build up on the spark plugs and foul them. If inspection of the spark plugs shows this to be the case, replace the standard NGK B9HS with NGK B9HS for the duration of the break-in period.

In addition to the above, the owner should take the motorcycle to an authorized Kawasaki Dealer for initial maintenance service at 800 ~ 1,600 km (500 ~ 1,000 mi).

Starting the Engine

- Check that the steering is unlocked.
- Check that the fuel tap is ON position.
- Make certain the engine stop switch is turned to the RUN position.
- Turn the ignition switch to the ON position.
- Make certain the gears are in neutral by seeing that the green neutral indicator light is lit.
- If the engine is cold, push the choke lever, leaving the throttle completely closed.
- Check that the right rear footrest is folded up.
- Kick the engine over.
- Even after the engine starts, keep the choke lever pushed in. When the engine is warm enough to idle without the use of the choke lever, release the lever.

Note: When the engine is already warm or on hot days, open the throttle part way instead of using the choke lever. Then kick over the engine.

Off the engine is flooded, kick with the throttle fully open until the engine starts.

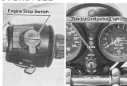

Moving Off

- Check that the side stand and kick pedal are up.
- Pull in the clutch lever.
- Shift into 1st gear.
- Open the throttle a little, and start to let out on the clutch lever very slowly.
- As the clutch starts to engage, open the throttle a little more, giving the engine just enough fuel to keep it from stalling.

Shifting Gears

- Close the throttle while pulling in the clutch lever at the same time.
- Shift into the next higher or lower gear.
- Open the throttle part way, and release the clutch lever.

CAUTION: When shifting down to a lower gear, do not shift at such a high speed that the engine is suddenly jerked into high rpm or into the red zone. Not only can this cause engine damage, but the rear wheel may skid and cause an accident. Downshifting should be done below 5,000 rpm for each gear.

Braking

- Close the throttle completely, leaving the clutch engaged (except when shifting gears) so that the engine will help slow down the motorcycle.
- Shift down one gear at a time so that you are finally in 1st gear just when you get completely stopped.
- When stopping, always apply both brakes at the same time if stopping quickly; normally the front brake should be applied a little more than the rear. Downshift or fully disengage the clutch as necessary to keep the engine from stalling or to stop more quickly.
- Never lock the brakes and cause the tires to skid. When turning a corner it is better not to brake at all, but if this is unavoidable, use only the rear brake.
- For emergency braking, disregard downshifting, and concentrate on applying the brakes as hard as possible without skidding.

Stopping the Engine

- Close the throttle completely.
- Shift the gears into neutral.
- Turn the ignition switch off, or if only stopping for a short time (less than one hour) on the road at night, turn it to **PARK**.
- Lock the steering.

Stopping the Motorcycle in an Emergency

Your Kawasaki motorcycle has been designed and manufactured to provide you optimum safety and convenience. However, in order to fully benefit from Kawasaki's safety engineering and craftsmanship, it is essential that you, the owner and operator, properly maintain your motorcycle and become thoroughly familiar with its operation. Improper maintenance and insufficient riding skills can create a dangerous situation known as throttle failure. Three of the most common causes of throttle failure are:

1. During removal of air cleaner by owner, dirt is allowed to enter and jam carburetor.
2. Idle rod is bent by improper disassembly of carburetor.
3. A novice may forget which direction throttle rotates; then jerk throttle wide open thinking he has shut it off; panic when machine accelerates violently instead of slowing down; and "freeze", holding throttle wide open.

Kawasaki has provided an engine stop switch or button on all its motorcycles which may be used to safely stop your motorcycle in an emergency. Alternatively, your motorcycle may be stopped by applying the breaks and disengaging the clutch. But if used the engine stop switch, turn off the ignition switch after stopping the motorcycle.

Safe Riding Technique

The points given below are applicable for everyday motorcycle use and should be carefully observed for safe and effective vehicle operation.

For safety, eye protection and a helmet are strongly recommended. Gloves and suitable footwear should also be used for added protection in case of a mishap.

When going up steep slopes, shift to a lower gear so that there is plenty of power to spare rather than overload the engine.

When applying the brakes, use both the front and the rear brakes. Applying only one brake for sudden braking may cause the motorcycle to skid and lose control.

When going down long slopes, control vehicle speed by closing the throttle. Use the front and rear brakes for auxiliary braking.

On rainy days, rely more on throttle to control vehicle speed and less on the front and rear brakes. The throttle should also be used judiciously to avoid skidding the rear wheel from too rapid acceleration or deceleration.

Riding at the proper rate of speed and avoiding unnecessary fast acceleration are important not only for safety and low fuel consumption but also for long vehicle life and quieter operation.

On rough roads, exercise caution, reduce speed, and grip the fuel tank with the knees when necessary for better stability.

When quick acceleration is necessary as in passing, shift to a lower gear to obtain the necessary power.

Do not downshift at too high an rpm to avoid damage to the engine from over-revving.

Avoiding unnecessary weaving is important to the safety of both the rider and other motorists.

Daily Safety Checks

In order to ride more enjoyably and more safely, the daily safety checks should never be neglected. Since engine trouble or a severe accident may be prevented through carrying out these simple checks and correcting any trouble, make it a habit each day before riding to check the following:

Gasoline	Gasoline in tank
Engine oil	Oil tank level sufficient (Pg. 33)
Transmission oil	Transmission oil level correct (Pg. 34)
Tires	Check for wear, cracks and other damage (Pg. 54) Air pressure: front 2.0 kg/cm ² (28 psi) rear 2.25 kg/cm ² (32 psi)
Spokes and rim	Tighten any loose spokes (Pg. 54)
Drive chain	Check overall condition; chain slack 20 ~ 25 mm ($\frac{3}{8}$ ~ 1 in.); oil as necessary (Pg. 57)
Battery	Electrolyte level above the lower level mark (Pg. 65)
Nuts and bolts	Tighten any loose nuts and bolts (Pg. 75)
Front Brake	Brake lever play less than 5 mm ($\frac{3}{16}$ in.); fluid up to level line; no damage to brake line or fittings (Pg. 48)

Clutch	Clutch lever play about 2 ~ 3 mm ($\frac{1}{16}$ ~ $\frac{1}{8}$ in); release properly, no slippage (Pg. 52)
Rear brake	Brake pedal play 20 ~ 30 mm ($\frac{3}{4}$ ~ 1 $\frac{1}{2}$ in); with pedal fully applied, indicator position within the "USABLE RANGE"; brake light functioning properly (Pg. 50)
Throttle grip	Throttle grip play correct (Pg. 64)
Steering	Check that the steering turns freely but has no play (Pg. 56)
Front fork	When pushing down on the handlebar with the front brake fully applied, the front fork functions properly; no oil leakage (Pg. 60)
Rear shock absorbers	Function properly, no oil leakage (Pg. 61)
Electrical equipment	Check that the headlight, tail/brake light, turn signals and horn work.
Engine	No abnormal engine noise

If any irregularities are found during the above checks, refer to the Maintenance and Adjustment Section to make the corrections necessary for safe operation.

Additional Considerations for High Speed Operation

Brakes	The importance of the brakes, especially at high speed operation, cannot be overemphasized. Check to see that they are correctly adjusted and functioning properly.
Steering	Looseness in the steering can cause loss of control. Check to see that the handlebar turns freely but has no play.
Tires	High speed operation is hard on tires, and good tires are crucial for riding safely. Examine their overall condition, inflate to the proper pressure, and check the wheel balance.
Spark Plugs	The standard plug is NGK B9HS, but for prolonged high speed operation use the next colder heat range plug B10H.
Gasoline	Have sufficient fuel for the high fuel consumption during high speed operation.
Transmission Oil	To avoid transmission seizure, make certain the oil level is at the upper level mark.
Engine Oil	Top up the oil tank.
Electrical Equipment	Make certain that the headlight, tail light, turn signals, horn, etc. all work properly.
Miscellaneous	Make certain that all nuts and bolts are tight and that all safety related parts are in good condition.

The maintenance and adjustments outlined in this section are easily carried out and must be done in accordance with the Periodic Maintenance Chart to keep the motorcycle in good running condition. Some of these are so important that you should make a habit of checking them frequently or daily as in the case of the daily safety checks.

If you are in doubt as to the adjustment or vehicle operation, please ask your authorized Kawasaki Dealer to check the motorcycle.

Please note that Kawasaki can not assume any responsibility for damage resulting from incorrect maintenance or improper adjustment done by the owner.

Periodic Maintenance Chart

Operation	Frequency	After initial 800 km (500 mi)	After initial 3,000 km (2,000 mi)	Every subsequent 3,000 km (2,000 mi)	Every subsequent 6,000 km (4,000 mi)	Page Reference
Change transmission oil	●	Every subsequent 6,000 km (3,000 mi)				34
Adjust brakes	●	●	●	●		48,50
Adjust drive chain	●	●	●	●		57
Check, adjust clutch mechanism	●	●	●	●		52
Check, adjust carburetors and oil pump	●	●	●	●		60,70
Check spoke tightness and wheel runout	●	●	●	●		54
Tighten nuts and bolts	●	●	●	●		75
Clean fuel tap	●	●	●	●		71
Clean, set spark plugs gap	●	●	●	●		67
*Check steering play	●				●	58
Carry out general lubrication			●	●		73
Clean air cleaner element			●	●		62

Operation \ Frequency	After initial 800 km (500 mi)	After initial 3,000 km (2,000 mi)	Every subsequent 3,000 km (2,000 mi)	Every subsequent 6,000 km (4,000 mi)	Page Reference
*Check timing	●	●	●		65
Check tire wear		●	●		65
Check drive chain wear		●	●		59
*Lubricate swing arm		●	●		—
*Lubricate cables		●	●		—
Lubricate drive chain	Every 800 km (500 mi)				59
Check brake wear	Every 6,000 km (4,000 mi)				48,51
*Check fork oil level	Every 6,000 km (4,000 mi)				—
Change air cleaner element	Every 10,000 km (6,000 mi)				63
*Change front fork oil	Every 10,000 km (6,000 mi)				60
*Change brake fluid	Every year or 10,000 km (6,000 mi)				—
*Regrease wheel bearings	Every 2 years or 20,000 km (12,500 mi)				—
*Regrease speedometer gear box	Every 2 years or 20,000 km (12,500 mi)				—
*Regrease brake camshaft	Every 2 years or 20,000 km (12,500 mi)				—
*Lubricate steering stem bearings	Every 2 years or 20,000 km (12,500 mi)				—

*Should be serviced by an authorized Kawasaki Dealer.

Front Brake Adjustment

The disc brake used on the front wheel is self adjusting except for hand lever play, which does not affect brake operation. To adjust lever play loosen the lock nut, turn the adjusting bolt slightly to set lever play to less than 5 mm ($\frac{3}{16}$ in), and tighten the lock nut.

Disc Brake Fluid

The disc brake fluid reservoir must be kept filled up to the line inside the reservoir, with one of the recommended types of disc brake fluid. If none of the recommended brake fluids are available, use extra heavy-duty brake fluid only from a container marked D.O.T.3.

Recommended Disc Brake Fluid

Atlas Extra Heavy Duty
Shell Super Heavy Duty
Texaco Super Heavy Duty
Wagner Lockheed Heavy Duty
Girling Amber

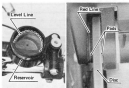
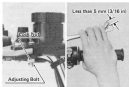

The fluid should be completely changed after one year or 10,000 km (6,000 mi), whichever comes first. It should also be changed if it becomes contaminated with dirt or water.

Brake Pad Replacement

The brake pads must be replaced when they are worn down through the red line.

Note: ●Except for adding fluid and adjusting hand lever play, disc brake maintenance should be performed only by a Kawasaki Dealer.

●If the brake lever comes close to the handlebar when it is applied, or if it feels mushy, there might be air in the brake lines or the brake may be defective. Since it is dangerous to operate the motorcycle under such conditions, have the brake checked immediately.

CAUTION: ○Do not spill brake fluid onto any painted surface.

○Do not use ordinary brake fluid.

○Do not mix two brands of fluid.

○Do not use fluid from a container that has been left open or that has been unsealed for a long time.

○Check for fluid leakage around the fittings.

○Check for brake hose and brake pipe damage.

Rear Brake Adjustment

Rear brake adjustment consists of two separate adjustments: brake pedal position, and brake pedal travel.

Brake Pedal Position

Check that the top of the brake pedal in its rest position is 20 ~ 30 mm ($\frac{3}{4}$ ~ 1 $\frac{1}{2}$ in) lower than the upper surface of the right front footrest. To adjust pedal position, loosen the lock nut, turn the adjusting bolt, and tighten the lock nut.



Brake Pedal Travel

•The brake pedal should have 20 ~ 30 mm ($\frac{3}{4}$ ~ 1 $\frac{1}{2}$ in) of travel from the rest position to the fully applied position when the pedal is pushed down lightly by hand. Adjustment is made by turning the adjusting nut at the end of the brake rod.

- Check the rear brake light switch.
- Check for brake drag.
- Check braking effectiveness.



CAUTION: If the brake lining wear indicator does not point within the **USABLE RANGE** when the brake is fully applied, the brake shoe linings have worn past the service limit. In this case, the brake shoes must be replaced and the drum and other brake parts examined by an authorized Kawasaki Dealer.

Brake Light Switch Adjustment

The rear brake light switch must turn on the brake light after about 15 mm ($\frac{5}{8}$ in) of brake pedal movement.

Adjust it by loosening the two mounting nuts, moving the switch up or down, and retightening the mounting nuts when the switch is properly positioned.

CAUTION: To avoid damaging the electrical connections inside the switch, be sure that the switch body does not turn during adjustment.

The brake light will also light when the front brake is applied, but the front brake light switch requires no adjustment.

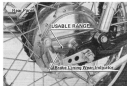

Clutch Adjustment

Due to friction plate wear and clutch cable stretching over a long period of use, the clutch must be adjusted periodically (Pg. 46).

- Loosen the lock nut at the middle of the clutch cable, and screw in the adjusting nut to give the cable plenty of play.
- Loosen the lock nut at the clutch lever just enough so that the adjuster will turn freely, and then turn the adjuster to make a 5~6 mm (0.20~0.24 in) gap between the adjuster and lock nut.
- Remove the engine sprocket cover.
- Loosen the clutch release lever lock nut, and back out the clutch adjusting screw 3 or 4 turns.
- Set the clutch release lever angle at an 80~90° to the clutch cable by turning the adjusting nut at the middle of the clutch cable.
- Turn the clutch adjusting screw in to where

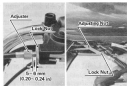

it suddenly becomes hard to turn, and then tighten the lock nut.

●Take up all the cable play with the adjusting nut at the middle of the cable, and then tighten the lock nut.

●Turn the adjuster at the clutch lever so that the clutch lever will have 2~3 mm ($\frac{1}{16}$ ~ $\frac{1}{8}$ in) of play, and tighten the lock nut.

●Replace the engine sprocket cover.

Note:○For minor corrections while riding, use the adjuster at the clutch lever.

○When adjustment is finished, start the engine and check that the clutch has no slippage and releases properly.

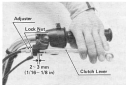

Wheel Inspection

Wheel Balance

An unbalanced wheel will cause the vehicle to vibrate or the steering to wobble, especially at high speeds. Since wheel balance greatly affects motorcycle safety, have the wheels inspected by a Kawasaki Dealer whenever abnormal handling is experienced during riding. Also, have the wheel balance inspected whenever a new tire is mounted.

Spokes and Rim

Spoke tightness should be inspected periodically (Pg. 46)

The axial rim runout should be under 3 mm (0.12 in), and the radial rim runout should be under 2 mm (0.08 in). A certain amount of runout (warp) can be corrected by re-centering the rim, i.e., by loosening some spokes and tightening others to change the positions of different parts of the rim. If the rim is badly warped however, it should be replaced.

Note: If there is any doubt, ask your authorized Kawasaki Dealer to inspect and adjust the rim.

Tires and Tubes

Proper tire inflation pressure is essential for safety, comfort and economy. Abnormally high or low tire air pressure has a bad effect on stability and handling. Under-inflation could result in tire failure due to flexing, and over-inflation could result in tire failure due to the decreased ability of the tire to cushion shock. Improper inflation will also cause the tire treads to wear unevenly, with most wear along the



outside of the treads when the tire is under-inflated, and along the center of the tread when the tire is over-inflated. Use an accurate tire pressure gauge often and measure the tire pressure when the tires are cold (that is, when the motorcycle has not been ridden more than a mile during the past 3 hours). Remember that tire pressure will change with air temperature and with altitude, and so must be changed and adjusted when conditions change.

Near the end of useful life, the tires become increasingly vulnerable to puncture or blowout. An accepted fact is that 90 percent of all tire failures occur during the last 10 percent of tread life (90 percent worn). So it is false economy and unsafe to use the tires until they are bald. Tread wear limits are specified in this manual to give you a guide for deciding when the tires should be replaced. In addition, a visible check of tread wear should be made frequently. Replace any tire that has worn down to the minimum allowable tread depth.

In the event of a flat tire resulting from a punctured tube, replace the tube only with a Kawasaki replacement tube. Repair of the tube is not recommended, but if undertaken, it must be done with extreme care to prevent a subsequent flat tire, and possible loss of control.

	Air Pressure (Cold)		Tire Size	Make Type	Minimum Tread Depth	
Front	2.0 kg/cm ² (28 psi)		3.25H-18 4PR	DUNLOP F68	1 mm (0.04 in)	
Rear	One Rider	2.25 kg/cm ² (32 psi)	4.00H-18	DUNLOP	Normal Speed	2 mm (0.08 in)
	Two Rider	2.5 kg/cm ² (36 psi)	4PR	K87 Mark III	Over 80 MPH	3 mm (0.12 in)

Steering Inspection

The steering should be checked periodically (Pg. 46).

To check the steering adjustment, first place a stand or block under the engine so that the front wheel is raised off the ground. Push the handlebar lightly to either side; if it continues moving under its own momentum, the steering is not too tight. Squatting in front of the motorcycle, grasp the lower ends of the front fork at the axle, and push and pull the front end back and forth; if play is felt, the steering is too loose.

Note: Since the steering adjustment is sensitive and crucial for safe operation, have it performed only by an authorized Kawasaki Dealer.



Drive Chain Inspection and Adjustment

The drive chain must be kept properly adjusted for safety and to prevent excessive wear. If the chain becomes badly worn or maladjusted – either too loose or too tight – the chain could jump off the sprocket or break. A jumped or broken chain could snag on the engine sprocket or lock the rear wheel, severely damaging the motorcycle and causing it to go out of control.

Inspection

With the motorcycle resting on the center stand, the chain should have about a 20~25 mm ($\frac{3}{4}$ ~1 in) slack measured midway between the sprockets. Rotate the rear wheel around to find the place where the chain is tightest (because it wears unevenly), and, if there is less than a 15 mm ($\frac{1}{2}$ in) or more than a 30 mm ($1\frac{1}{8}$ in) slack, the chain should be re-adjusted.

In addition to checking the slack, rotate the rear wheel to inspect the drive chain and sprockets for damaged rollers, loose pins, uneven or excessive wear, rusted pins and links, unevenly worn teeth, and damaged teeth.

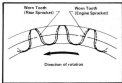

If there is damage or excessive wear, have the drive chain and/or the sprockets replaced by an authorized Kawasaki Dealer.

Adjustment

- Loosen the torque link nut and both chain adjuster lock nuts.
- Remove the cotter pin and loosen the rear axle nut.
- Turn in the left and right chain adjuster bolts evenly until the drive chain has the correct amount of slack. To keep the chain and wheel aligned, the notch on the left chain adjuster should come to the same swing arm mark that the right chain adjuster notch comes to.
- Tighten the axle and torque link nuts, and replace the cotter pin.
- Tighten the chain adjuster lock nuts.
- Check the rear brake adjustment (Pg. 50).
- Check the rear brake light switch adjustment (Pg. 51).



Chain Replacement

Check chain wear by first stretching the chain tight (adjust it taut or hang a 10kg-20lb-weight on it) and then measure the length of 20 links. If the distance from the center of the 1st pin to the center of the 21st pin is more than 323 mm (12.7 in), the chain should be replaced. **WARNING:** For safety, use only the standard chain: Enuma EK428SH-G, 118 links. This is an endless type and should not be cut for installation; have it installed by a Kawasaki Dealer.



Drive Chain Lubrication

To minimize chain wear, the drive chain should be lubricated periodically (Pg. 47), after riding in the rain, and after washing the vehicle.

Lubricate the chain by applying chain lube or SAE 90 gear oil to the sides of the rollers and between the links so that the oil will penetrate to the pins and bushings. Wipe off excess oil. If the chain is dirty, clean the chain using a brush and solvent before chain lubrication.

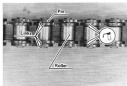

Front Fork Inspection and Maintenance

Inspection

Pushing down on the handlebar with the front brake fully applied, check that the front fork functions properly. Check the dust seal for damage, and look for any signs of oil leakage.

In case of improperly functioning shock absorbers, dust seal damage, or oil leakage, see your authorized Kawasaki Dealer.

Maintenance

Dirt or sand that has worked its way past a dust seal will eventually damage the oil seal causing oil leakage. Periodically, slide up the dust seals and clean out any dirt or sand. Be careful not to damage either the oil seal or the inner tube surface.

Since the front fork oil deteriorates with use, have the oil in both tubes changed periodically by your authorized Kawasaki Dealer (Pg. 47).



Rear Shock Absorber Inspection and Adjustment

Inspection

Since the rear shock absorbers are sealed units and can not be disassembled, only external checks of operation are necessary.

Check that the rear shock absorbers function properly and that there is no oil leakage or bushing damage, and make sure that the mountings are tight.

In case any irregularity is found during inspection, see your authorized Kawasaki Dealer.

Adjustment

The rear shock absorbers have 3 positions so that the shock absorbers can be adjusted for different road and loading conditions.

If the spring action feels too soft or too stiff, adjust it in accordance with the following table.

Position	Shock Tension	Conditions
1	Standard	Single rider
2	Slightly hard	Heavy rider, luggage strapped on
3	Hard	Rider and passenger

Note: Always adjust both shock absorbers to the same position.



Air Cleaner Maintenance

A clogged air cleaner restricts the engine's air intake, increasing gas consumption, reducing engine power, and causing spark plug fouling.

Air Cleaner Cleaning

The air cleaner element must be cleaned periodically (Pg. 46). In dusty areas, the element should be cleaned sooner than each recommended distance. After riding through rain or on muddy roads, the element should be cleaned immediately.

To remove the element for inspection and cleaning:

- Loosen the chain case cover.
- Loosen the one large and three small clamps and pull off the air duct.
- Remove the left and center carburetors from the inlet pipe and move it aside.
- Remove the cleaner housing mounting screw and pull out the housing and element together.



•Unhook the cleaner housing, and remove the element.

Clean the element by swishing it around in a bath of some kind of solvent having a high flash point. After the element is clean, dry it with compressed air or by shaking it.

After cleaning, apply a small amount of SAE 30 motor oil to the felt disc face of the element. Oil, however must not be applied to the main body of the element.

CAUTION: ○Clean the element in a well-ventilated area, and take ample care that there are no sparks or flame anywhere near the working area.

○Because of the danger of highly flammable liquids, do not use gasoline or some kind of solvent having a low flash point to clean the element.

○A break in the element material or damage to the sponge gasket will allow dirt and dust to pass through into the carburetors and eventually damage the engine. If any part of the element is damaged, the element must be replaced.

Element Replacement

Replace the element after 10,000 km (6,000 mi), after cleaning it 5 times, or if it is damaged.

Note: When the element is replaced, be sure that the clamps are secure, but not so tight that they will damage the tube.



Headlight Beam Adjustment

Adjust the beam horizontally by turning the adjusting screw (not on the European model).

To adjust the beam vertically, remove both screws from the side of the headlight, loosen the mounting nuts, and move the headlight to the position desired.



Throttle Grip Play Adjustment

Check that the throttle grip has 2 ~ 3 mm ($\frac{3}{16}$ ~ $\frac{1}{4}$ in) of play and turns smoothly.

If there is too much or too little play, adjust it with the adjusting nut, and then tighten the lock nut.

Note: With the engine idling, turn the handlebar to either side. If handlebar movement changes idle speed, the throttle, carburetor or oil pump cables may be damaged, or the routing of the cables may be unsatisfactory.

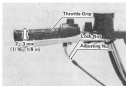

Ignition Timing

This motorcycle has a capacitor discharge ignition system, which has no moving parts. Although it is seldom necessary to adjust the ignition timing, have the timing adjusted by a Kawasaki Dealer should it become necessary.

The ignition timing should be checked periodically (Pg. 47).

Battery Maintenance

Battery Electrolyte Level Inspection

Keep the electrolyte level between the upper and lower level marks. When it gets low, remove the battery filler caps and add only distilled water until the electrolyte level in each cell reaches the upper level mark.

Battery Removal and Installation

Battery removal is necessary when the battery electrolyte specific gravity reading is below 1.200, indicating a need for battery recharging.



- a. Remove the battery band, and disconnect first the ground (–) negative lead connection and then the positive (+) lead.
- b. Battery installation is performed in the reverse order of removal.

CAUTION: •Route the battery vent hose as shown in the caution label.

•Make sure the battery vent hose end is kept away from the chain, as electrolyte from the battery vent hose will corrode and dangerously weaken the chain.

•Do not let the battery vent hose get folded or pinched, and route it away from the exhaust system.

•Keep the battery terminals clean, and put a light coat of grease on them to prevent corrosion.



Spark Plug Maintenance

The standard spark plug is a NGK B9HS. It should have a 0.9 ~ 1.0 mm (0.035 ~ 0.039 in) gap, and be tightened with 2.5 ~ 3.0 kg-m (18.5 ~ 21.5 ft-lbs) of torque.

Maintenance

The spark plugs should be taken out periodically for cleaning and to reset the gap (Pg. 46). If either plug is oily or has carbon built up on it, clean it (preferably in a sand-blasting device) and then clean off any abrasive particles. The plug may also be cleaned using solvent and a wire brush or other suitable tool. Measure the gap with a thickness gauge, and adjust the gap if incorrect by bending the outer electrode.

Heat Range

To find out whether the right temperature plugs are being used, pull them out and examine the ceramic insulator around the center electrode. If the ceramic is a light brown color, the spark plugs are correctly matched to engine temperature. If the ceramic is burned white, the plugs should be replaced with the next colder type, NGK B10H. If the ceramic is black, the plugs should be replaced with the next hotter type, NGK B8HS. Be sure that the spark plug has the proper amount of gap whenever it was replaced.

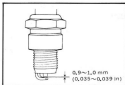

Idle Speed Adjustment

Idle speed adjustment is carried out using the air screws and idling screws.

- First screw in the air screws fully, but not tightly, and back them out 1½ turns.
- After thoroughly warming up the engine, turn the idling screws to set the idle speed to the lowest stable speed obtainable, normally between 1,200 ~ 1,300 rpm.
- Listen to the exhaust noise, and place your hands behind the mufflers to feel the exhaust pressure.
- If there is a variation in noise or exhaust pressure among the cylinders, re-adjust the individual idling screws to make combustion uniform.
- With the engine idling, turn the handlebar to either side. If handlebar movement changes idle speed, the throttle, carburetor or oil pump cables may be damaged, or the routing of the cables may be unsatisfactory.

Note: If necessary, ask your authorized Kawasaki Dealer to make the inspection and adjustment.



Carburetor Cable Adjustment

Due to stretching of the carburetor cables, the throttle valves may not respond immediately to the opening of the throttle, and the oil pump output may be too large at certain throttle openings. Check and adjust the carburetor cables periodically (Pg. 46).

- Screw in the idling screws until the throttle valves are fully closed. Using the adjusters at the top of the carburetors, adjust all the play out of the outer sleeve of each cable, and tighten each lock nut.
- Check that the outer sleeve of each carburetor cable is seated properly in the cable adjuster.
- Check the throttle grip play. (Pg. 64).
- Check the oil pump adjustment. (Pg. 70).
- Adjust engine idle speed. (Pg. 68).

Note: After the idle speed adjustment is made, the carburetor cables will have a small amount of play. This play is correct and should not be altered.



Oil Pump Cable Adjustment

Due to stretching of the oil pump cable, the oil pump output may be too low at certain throttle openings. Check and adjust the oil pump cable periodically (Pg. 46).

Check to see that the mark on the oil pump lever is aligned with the corresponding mark on the oil pump lever stopper. If it is not, turn the adjuster to line up the two marks, and tighten the lock nut.

Note: ●Make sure the banjo bolts are tight, but do not overtighten them. Any oil leakage should be corrected before riding.

●After oil pump cable adjustment, check that the outer sleeve of the oil pump cable is seated properly in the cable adjuster.

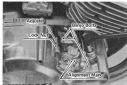

Choke Cable Adjustment

First turn the adjuster at the lower end of each choke cable so that the choke cables have less than 1 mm ($\frac{1}{16}$ in) of play.

Then using the adjusting nut at the upper end of the cable, adjust the choke lever for about 4 ~ 6 mm ($\frac{3}{16}$ ~ $\frac{1}{4}$ in) of play measured at the end of the lever, and tighten the lock nut. **Note:** After the choke cable adjustment, check that the choke lever returns properly and that the inner cables slide smoothly. Also, check that each outer sleeve of each choke cable is seated properly in the cable adjuster and adjusting nut.

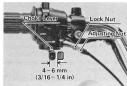

Fuel Tap Cleaning

Accumulation of water or sediment in the fuel tank and tap will restrict the flow of fuel and cause the carburetors to malfunction. The fuel tap should be cleaned out periodically in the following manner (Pg. 45):

- Turn the fuel tap lever to ON and unscrew the sediment cup from the bottom of fuel tap. The gasket and filter are mounted on the fuel tap. Being careful not to damage the gasket and filter, remove the filter using a screwdriver,



•Using a piece of cloth, wipe out the inside of the fuel tap, wash the cup and filter in regular solvent and then reassemble.

Note: If water has accumulated in the sediment cup, water may also be accumulated in the float bowls. In this case have the carburetors checked by your authorized Kawasaki Dealer.

•After washing, check the gasket and filter. Replace them if damaged.

•Make sure the sediment cup is tight. Turn the fuel tap lever a few times to the "PRI" position, and check for leaks. If fuel leaks from the sediment cup, the gasket may be damaged. Visually inspect the gasket and replace it if necessary.

CAUTION: Clean the fuel tap in a well-ventilated area, and take ample care that there are no sparks or flame anywhere the working area.

•Never clean out the fuel tank or tap when the engine is still warm.

•Wipe any fuel off the engine before starting it.



Decarbonization

The exhaust system (i.e., baffle tube, muffler, piston head, exhaust port and cylinder head) can fill up with carbon and other exhaust by-products over an extended period of operation, resulting in a drop in performance. Decarbonization of the exhaust system should be done periodically by an authorized Kawasaki Dealer.

Lubrication

In order to get maximum length of use from all parts and to keep the motorcycle running safely, it must be kept properly lubricated.

Using SAE 30 motor oil, lubricate the points indicated whenever they are dry, after riding through rain, or after washing the motorcycle. Grease the places indicated with regular cup grease at least every 6 months or 3,000 km (2,000 mi).

After several thousand kilometers of service, in addition to the points shown here, other parts should be inspected and lubricated by a Kawasaki Dealer.





Bolt and Nut Tightening

Every day before riding, check without fail the tightness of the bolts and nuts listed here. Also, check to see that each cotter pin is in place and in good condition.

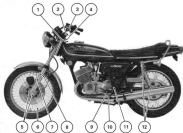

1. Steering Stem Clamp
2. Handlebar Clamp Bolts
3. Clutch Lever Holder Bolt
4. Stem Head Bolt
5. Front Axle Clamp Nut
6. Spokes
7. Caliper Mounting Bolts
8. Front Fender Mounting Bolts
9. Shift Pedal Bolt
10. Footrest Mounting Bolt
11. Pivot Shaft Nut
12. Rear Shock Absorber Nuts and Bolts

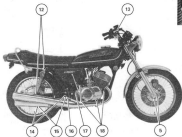

- 13. Front Brake Lever Holder Bolt
- 14. Torque Link Nuts
- 15. Cotter Pins (Torque Link)
- 16. Rear Brake Pedal Nut
- 17. Kick Pedal Bolt
- 18. Engine Mounting Bolt
- 19. Cotter Pin (Footrest)

1) Preparation for washing

Before washing, precautions must be taken to keep water off the following parts:

- Rear opening of the mufflers Cover with plastic bags secured with rubber bands.
- Clutch and brake levers, hand grips Cover with plastic bags.
- Ignition switch Cover the keyhole with tape.
- Air cleaner intakeClose up the openings with tape, or stuff in rags.

2) Where to be careful

Avoid spraying water with any great force near the following places:

- Speedometer and tachometer
- Rear hub

If water gets inside the rear hub, the rear brake will not function until it dries out.

- Under the fuel tank and the seat

If water gets into the ignition coils or into a spark plug caps, the spark will jump through the water and be grounded out. When this happens, the motorcycle will not start and the affected parts must be wiped dry.

3) After washing

- Remove the plastic bags, and clear the air cleaner intakes.
- Test the brakes before motorcycle operation.
- Lubricate the chain immediately to keep it from rusting.

STORAGE

When the motorcycle is to be stored for any length of time, such as during the winter season, it should be prepared for storage as follows:

- Clean the entire vehicle thoroughly.
- Empty the gasoline from the fuel tank, and empty the carburetor float bowls. (If left in for long time, the gasoline will sour.)
- Remove the empty fuel tank, pour about $\frac{1}{2}$ pint of motor oil into the tank, roll the tank around to coat the inner surfaces thoroughly, and pour out the excess oil.
- Remove the spark plugs and put several drops of SAE 30 oil into each cylinder. Kick the engine over slowly a few times to coat the cylinder walls with oil, and replace the plugs.
- Reduce tire pressure by about 20%.
- Set the motorcycle on a box or stand so that both wheels are raised off the ground. (If this cannot be done, put boards under the front and rear wheels to keep dampness away from the tire rubber.)
- Spray oil on all unpainted metal surfaces to prevent rusting. Avoid getting oil on rubber parts or in the brakes.
- Lubricate the drive chain and all the cables.
- Remove the battery, and store it where it will not be exposed to direct sunlight, moisture, or freezing temperatures. During storage it should be given a slow charge (one ampere or less) about once a month.
- Tie a plastic bag over the exhaust pipes to prevent moisture from entering.
- Put a cover over the motorcycle to keep dust and dirt from collecting on it.

To put the motorcycle back into use after storage:

- Check the electrolyte level in the battery, charge the battery if necessary, and install it in the motorcycle. Be careful that the battery vent hose is not pinched and that it is routed away from the chain.
- Bring tire pressure up to normal:

Front tire	2.0	kg/cm ²	(28 psi)
Rear tire	2.25	kg/cm ²	(32 psi)
- Make sure the spark plugs are tight.
- Check the engine oil. (Pg. 33).
- Fill the fuel tank with fuel.
- Run the engine for about five minutes to warm the oil, and drain the transmission oil.
- Put in fresh transmission oil. (Pg. 34).
- Check all the points listed under Daily Safety Checks. (Pg. 42,43).
- Lubricate the chain and the other points listed in the Lubrication Section. (Pg. 59,73).

Engine doesn't start

- No gasoline in tank
- Gasoline not reaching carburetor
 - Fuel tap lever position incorrect
 - Fuel tap obstructed or defective
- Flooded
 - If the engine is flooded, kick it over with the throttle fully open to let more air in.
- Choke not working normally
 - Choke cable play maladjusted
 - Choke lever not returning
- Compression leakage
 - Spark plug loose
 - Cylinder head not sufficiently tightened down
- Spark plug not firing

Engine stops

- No gasoline
- Fuel tap clogged or lever position wrong

- Fuel tank cap air vent obstructed
- Overheated
 - No engine oil
 - Transmission oil low
 - Incorrect spark plug
 - Carburetor adjusted too lean
 - Timing maladjusted
 - Carbon built up in combustion chamber

No power

- Compression leakage
 - Spark plug loose
 - Cylinder head not sufficiently tightened down
- Clutch slipping
 - Clutch maladjusted or worn
- Timing maladjusted
- Incorrect firing
 - Spark plug defective
 - Ignition coil defective

KH500-A8 Wiring Diagram (Canada Model)

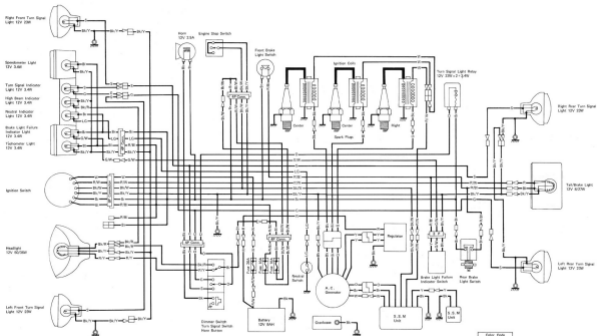

Color	Code
B	Blue
Br	Brown
Blk	Black
R	Red
Y	Yellow
W	White
LS	Light Green
Gr	Green
P	Pink
Or	Orange

Ignition Switch Conventions

Lead Color	Ignition SW	E	St. L.	Tail	Brake	Oil
IGN	→	BL/V	Blk	W	White	Green
IGN	→	→	→	→	→	→
PAK	→	→	→	→	→	→

KH500-A8 Wiring Diagram (US Model)

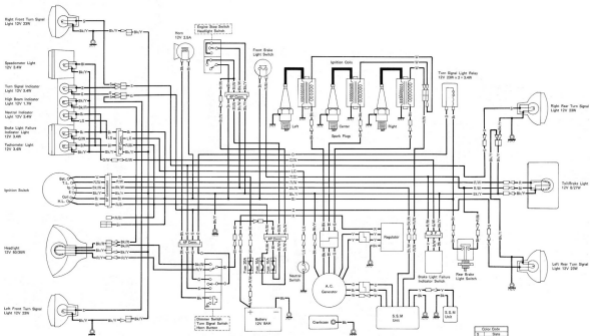

Ignition Switch Connections

Lead	Ignition	S	RLL	Y	W	W	W	W	W
Coil	BL/W	BL/Y	Blu	5.0W	White	Black			
IGN									
IGN									
IGN									

- W White
- B Black
- R Red
- Y Yellow
- L/L Light Green
- Bl Blue
- Gr Green
- Brn Brown
- Pk Pink
- Or Orange

KAWASAKI
HEAVY INDUSTRIES, LTD.
ENGINE AND MOTORCYCLE GROUP.

Part No. 99997-803-01

Printed in Japan

May. 1975. ①. 10. ①