

# **KAWASAKI**

**Model**

**350:S2-A**

## **Exclusive Parts List For European Market**

**KAWASAKI HEAVY INDUSTRIES, LTD.**

MOTORCYCLE DIVISION

1-1, Kawasaki-Cho, Akashi, Hyogo Pref, Japan.

10. Nov. 1972

NO. 99997-604 ©



## FOREWORD

This catalogue lists parts for the S2-A.

It should be used in conjunction with the S2 PARTS CATALOGUE No.99997-513 (Rev. 1, July, 1971).

Any parts numbers not listed in this supplement catalogue can be found in the S2 Parts Catalogue No.99997-513.



Right Side View



Left Side View

# KAWASAKI 350:S2-A

## INDEX

---

1.	Cylinder Head, Cylinder .....	1
3.	Piston, Crankshaft .....	1
4.	Clutch .....	1
7.	Kickstarter Mechanism .....	3
8-2.	Engine Covers .....	3
9-2.	Electrical Equipment for Engine .....	3
12.	Oil Pump .....	3
13.	Frame .....	5
14.	Swinging Arm, Rear Shock Absorber .....	7
15.	Footrests, Stands, Brake Pedal .....	9
16.	Handlebar, Grips .....	7
17.	Front Fork .....	11
18.	Fenders .....	15
19.	Tires, Rims .....	17
20.	Front Hub .....	19
21.	Rear Hub .....	17
22.	Fuel Tank .....	21
23.	Oil Tank .....	23
24.	Dual Seat .....	25
25.	Cables .....	29
26-1.	Electrical Equipment A .....	31
26-2.	Electrical Equipment B .....	33
26-3.	Electrical Equipment (German Type) .....	35
26-4.	Electrical Equipment (French Type) .....	35
27.	Electrical Equipment C .....	37
30.	Disc Brake Equipment A .....	39
31.	Disc Brake Equipment B .....	41
	Numerical Parts Index .....	44
	Standard Hardwares Index .....	48

---

1. Cylinder Head, Cylinder

---

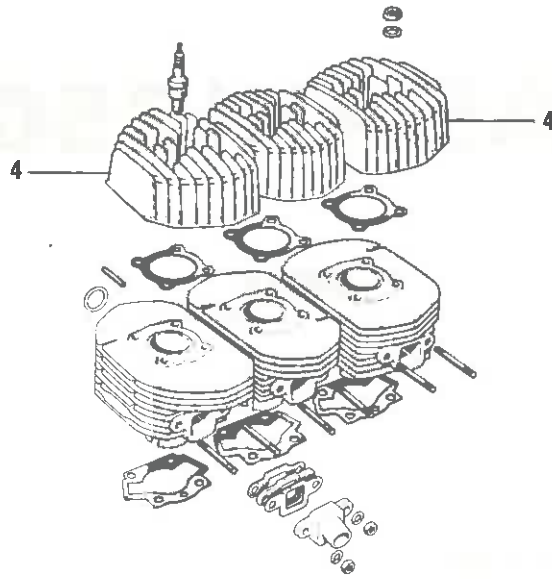

3. Piston, Crankshaft

---

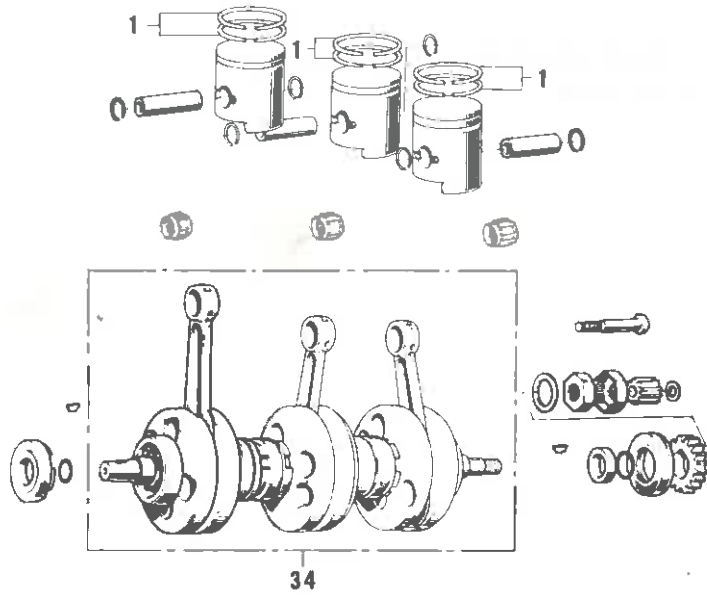

4. Clutch

---

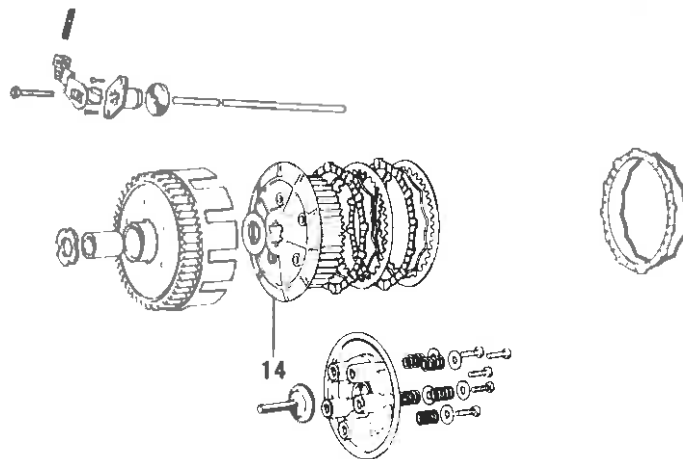

## 1. Cylinder Head, Cylinder

Ref. No.	Part No.	Part Name	Quantity	Remarks
4	11001-053-80	CYLINDER HEAD, Buff Finish	2	for L.H. & R.H.

## 3. Piston, Crankshaft

Ref. No.	Part No.	Part Name	Quantity	Remarks
1	13008-039	RING SET—piston, STD	1 x 3	TSS
	13025-043	RING SET—piston, 0.020" over size	1 x 3	TSS
	13024-047	RING SET—piston, 0.040" over size	1 x 3	TSS
34	13031-040	CRANK & CONROD ASSY	1	

## 4. Clutch

Ref. No.	Part No.	Part Name	Quantity	Remarks
13 ~ 22	13081-055	CLUTCH ASSY	1	
14	13087-033	HUB—clutch	1	
15		Not required for 13087-033		

7. Kickstarter Mechanism

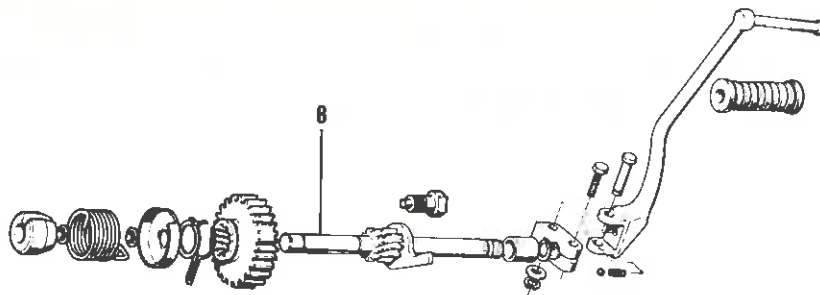

8-2. Engine Covers

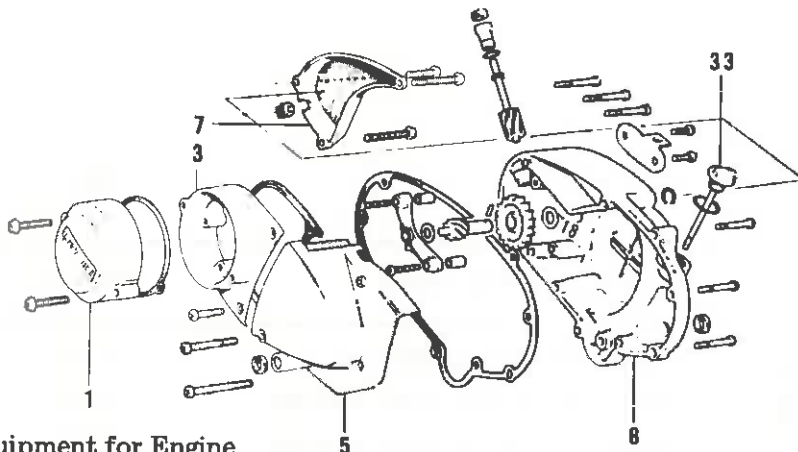

9-2. Electrical Equipment for Engine

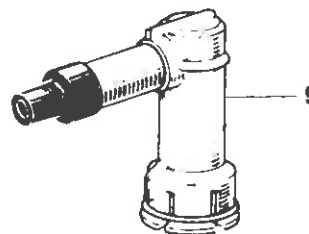
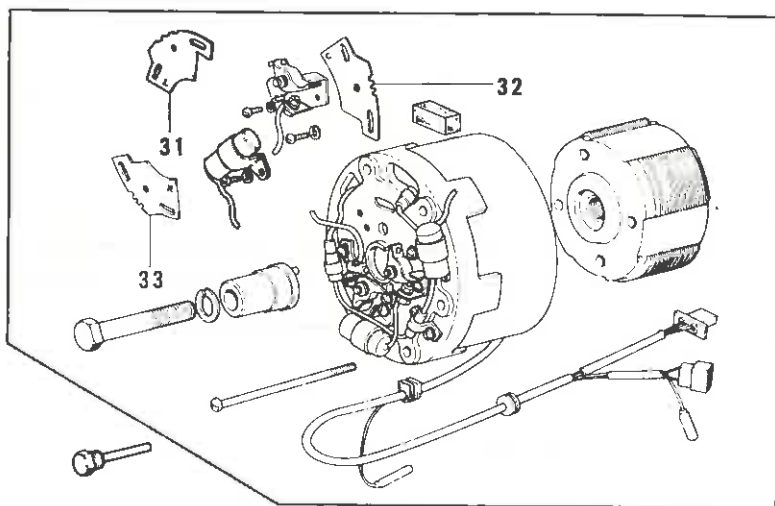

12. Oil Pump

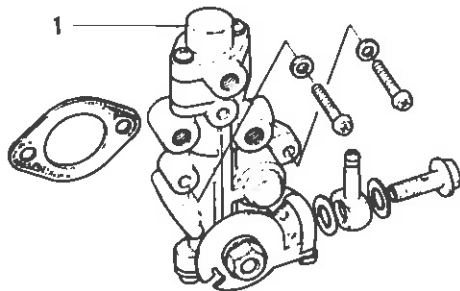

## 7. Kickstarter Mechanism

Ref. No.	Part No.	Part Name	Quantity	Remarks
8	13245-003	SHAFT—kickstarter	1	

## 8-2. Engine Covers

Ref. No.	Part No.	Part Name	Quantity	Remarks
1	14027-010-36	CAP—contact breaker point	1	Melamine Clear
3	14031-052-36	COVER—L.H. engine	1	Melamine Clear
5	14026-008-36	COVER—front chain	1	Melamine Clear
7	14030-030-36	COVER—oil pump	1	Melamine Clear
8	14032-061-36 <del>MA</del>	COVER—R.H. engine	1	Melamine Clear
33	16115-017	OIL FILLER	1	

## 9-2. Electrical Equipment for Engine

Ref. No.	Part No.	Part Name	Quantity	Remarks
9	21130-013	CAP—spark plug cap	3	
31	21156-003	PLATE—contact breaker, L.H.	1	
32	21156-004	PLATE—contact breaker, Center	1	
33	21156-005	PLATE—contact breaker, R.H.	1	

## 12. Oil Pump

Ref. No.	Part No.	Part Name	Quantity	Remarks
1	16082-041	OIL PUMP ASSY	1	



13. Frame

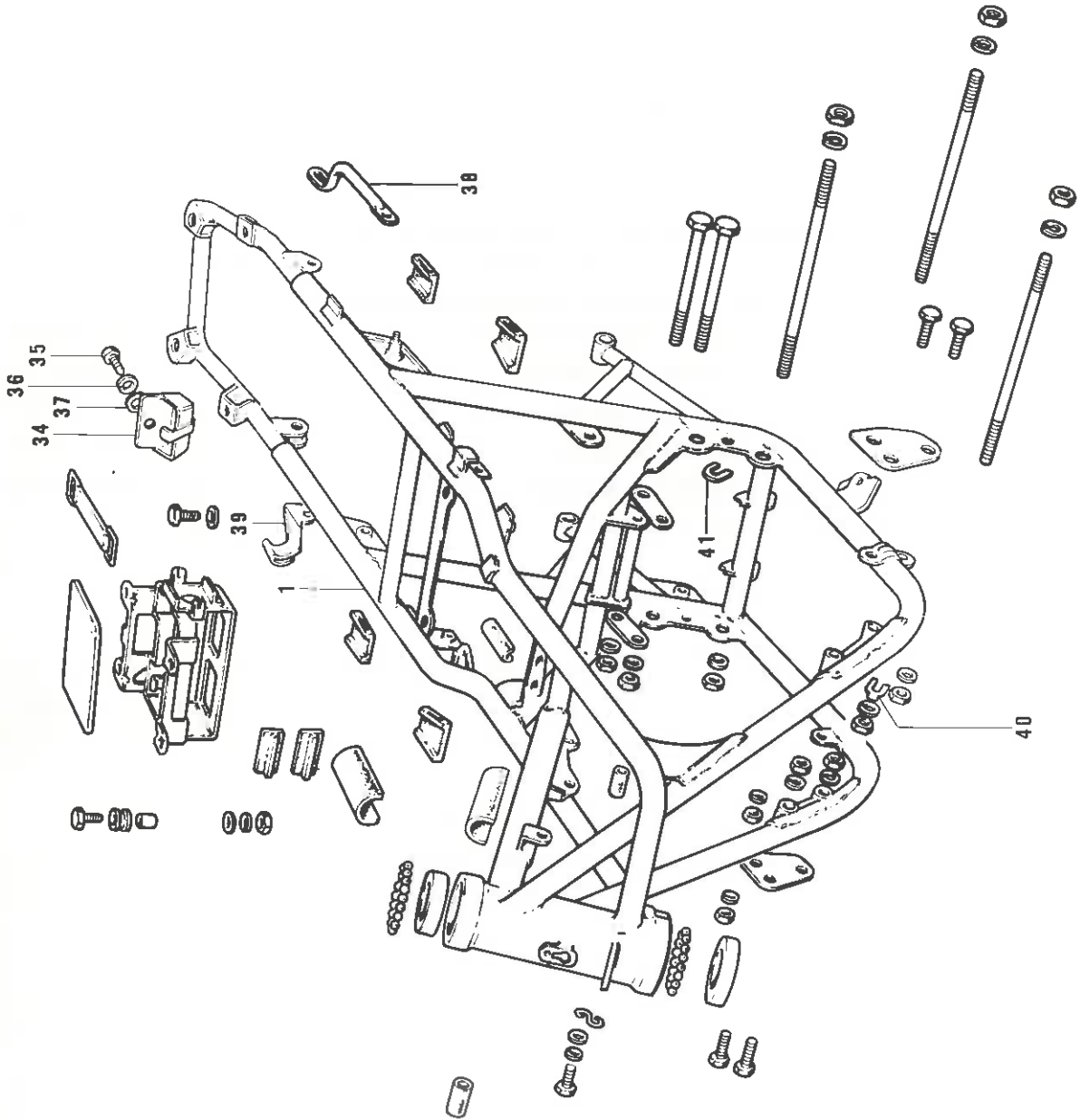

## 13. Frame

Ref. No.	Part No.	Part Name	Quantity	Remarks
1	32002-061	FRAME	1	
34	32132-001	COVER—spark plug	1	
35	110B0614	BOLT—hex head, 6 x 14	1	
	116B0614	BOLT—hex head, 6 x 14	ALT	
36	461F0600	WASHER—spring, 6 m/m	1	
37	92022-024	WASHER—plain	1	
38	32109-013	FRAME GRIP	1	
39	32122-006	BRACKET—helmet holder	1	
40	92025-048	SHIM—engine fitting, 0.5t	AR	
	92025-049	SHIM—engine fitting, 0.8t	AR	
	92025-050	SHIM—engine fitting, 1.0t	AR	
	92025-051	SHIM—engine fitting, 1.6t	AR	
	92025-052	SHIM—engine fitting, 2.0t	AR	
41	92025-053	SHIM—engine fitting, 0.5t	AR	
	92025-054	SHIM—engine fitting, 0.8t	AR	
	92025-055	SHIM—engine fitting, 1.0t	AR	
	92025-056	SHIM—engine fitting, 1.6t	AR	
	92025-057	SHIM—engine fitting, 2.0t	AR	
	92025-058	SHIM—engine fitting, 2.3t	AR	

14. Swinging Arm, Rear Shock Absorber

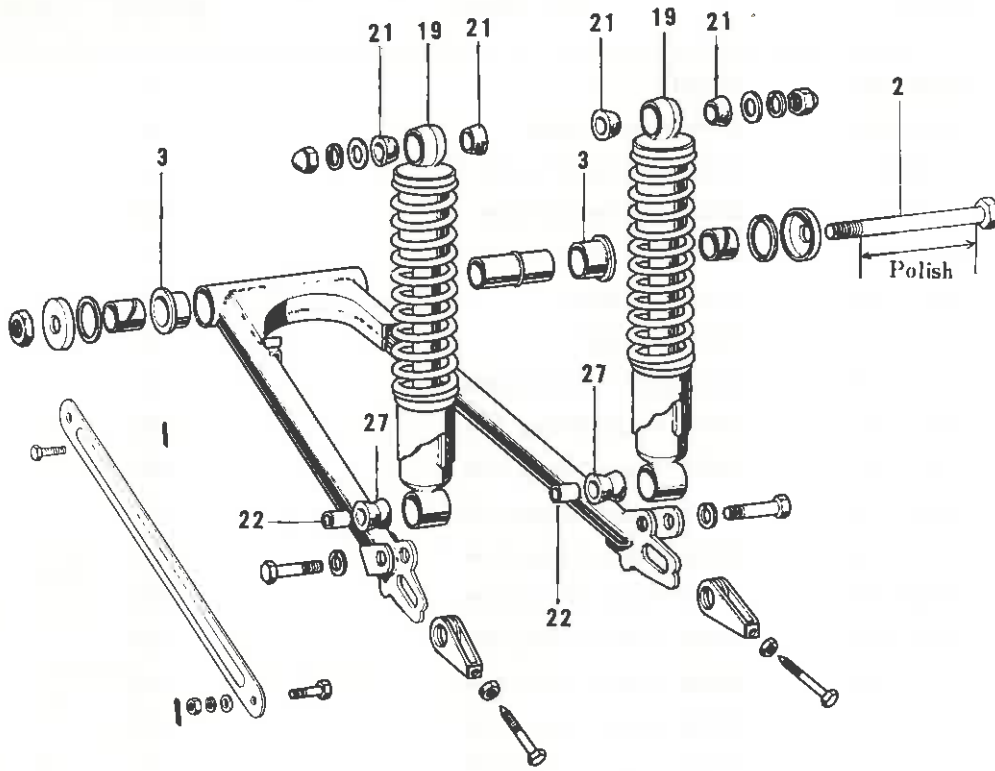

16. Handlebar, Grips

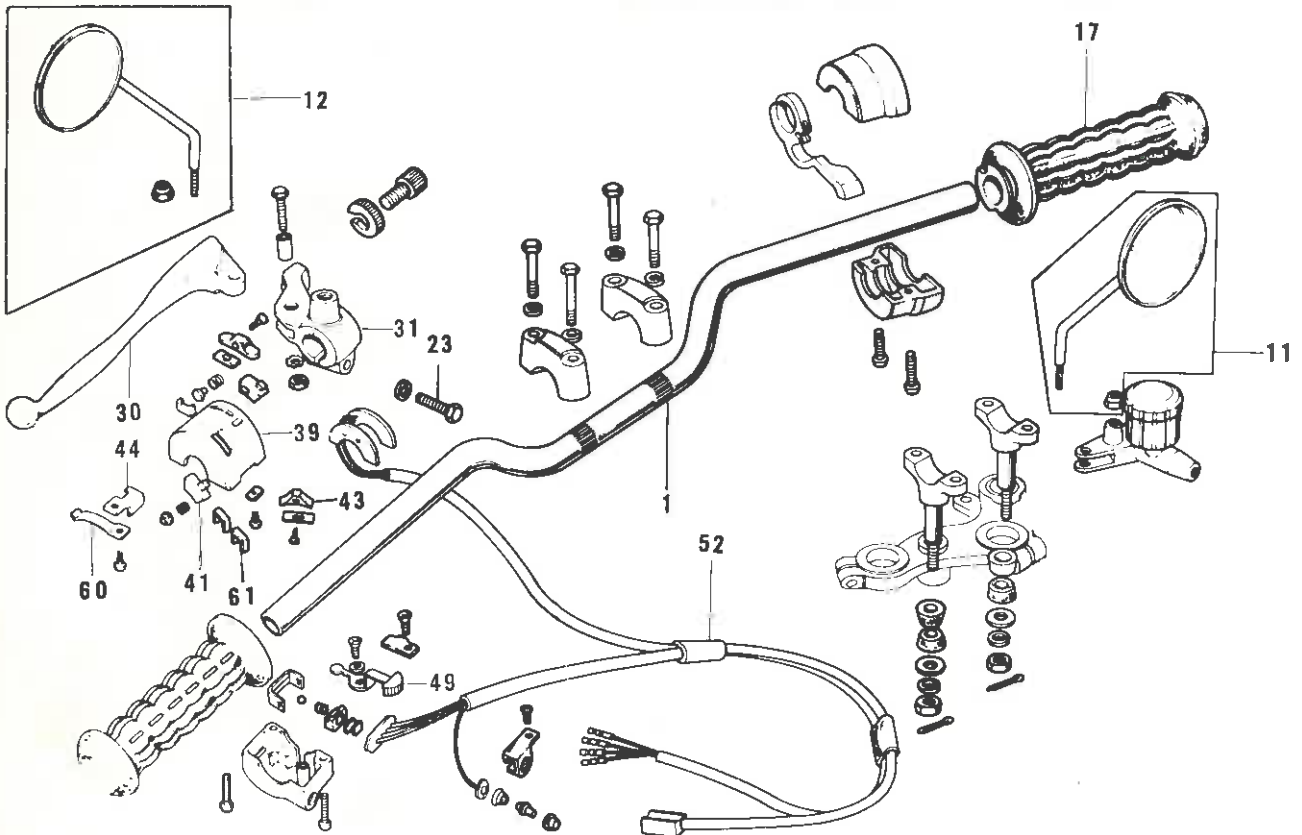

## 14. Swinging Arm, Rear Shock Absorber

Ref. No.	Part No.	Part Name	Quantity	Remarks
2	33032-037	SHAFT—swinging arm pivot	1	
3	33033-009	BUSHING—swinging arm	2	
19,21,22,27	45014-062	SHOCK ABSORBER—rear	2	
21	45017-001	BUSHING—shock absorber rubber	4	
22	45016-003	BUSHING—shock absorber	2	
27	45017-007	BUSHING—shock absorber rubber	2	

## 16. Handlebar, Grips

Ref. No.	Part No.	Part Name	Quantity	Remarks
1	46006-011	HANDLEBAR, semi-low	1	
11	56002-020	REAR VIEW MIRROR, R.H.	1	Option
12	56003-009	REAR VIEW MIRROR, L.H.	1	
14 ~ 19	46018-018	CASE ASSY, R.H.	1	
17	46019-023	GRIP ASSY—throttle	1	
23	110N0625	BOLT—hex head, 6 x 25	1	
21 ~ 28 30 ~ 31	46076-027	LEVER ASSY—clutch	1	
30	46092-015	LEVER—clutch	1	ADC5
31	46094-011-21	HOLDER—clutch lever	1	Flat Black
32 ~ 61	46091-010	CASE ASSY, L.H.	1	
39	46086-017	CASE—L.H. switch upper	1	
41	46089-011	SWITCH B—L.H.	1	
43	46044-014	KNOB A—L.H. switch	1	
44	46085-021	HOLDER A—L.H. switch upper	1	
49	46043-006	KNOB—switch	1	
52	46082-027	WIRING HARNESS—L.H. switch	1	
60	46031-008	SPRING PLATE—lighting switch	1	
61	46080-005	PLATE—L.H. switch contact	1	

15. Footrest, Stands, Brake Pedal

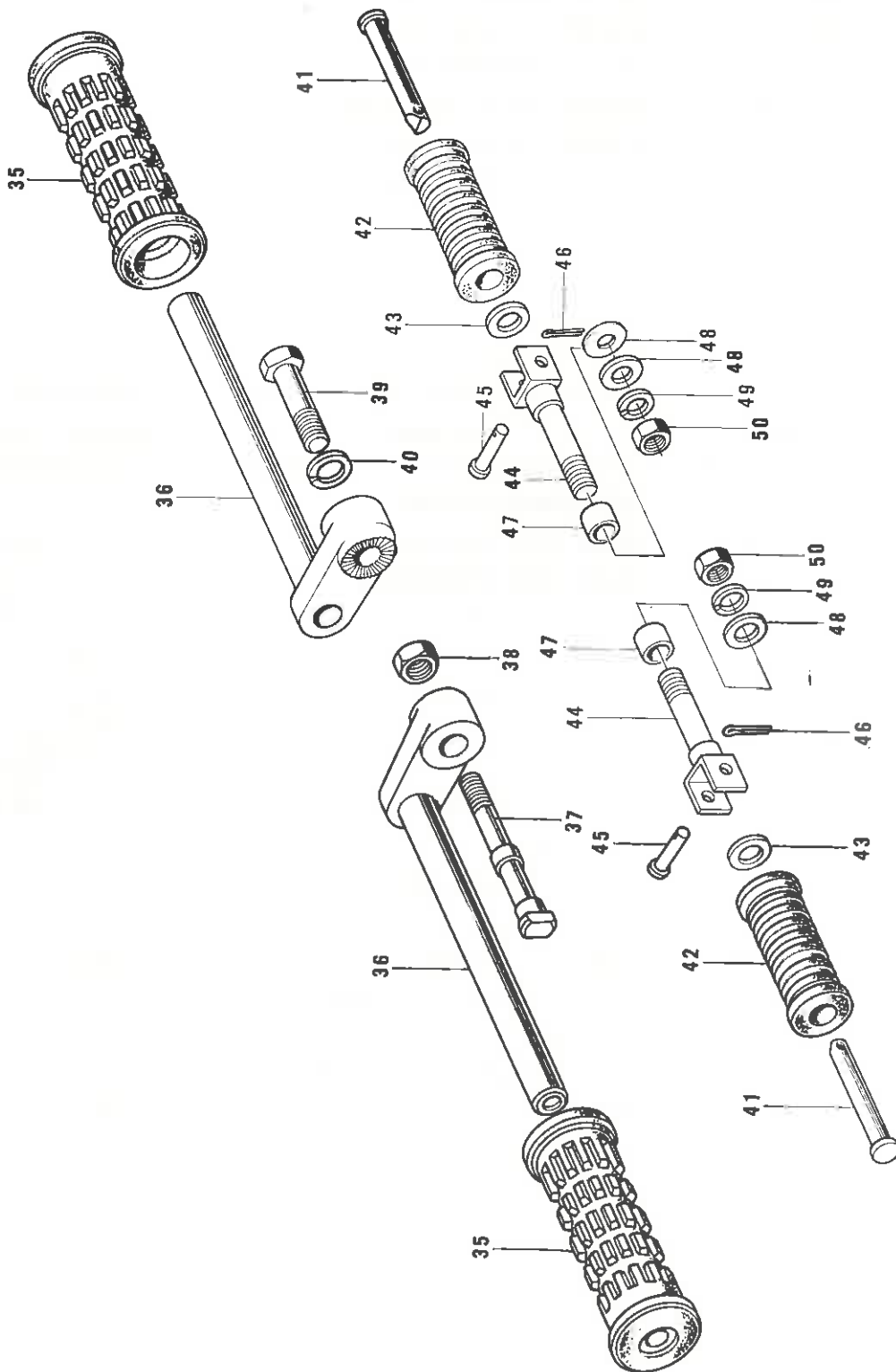

## 15. Footrests, Stands, Brake Pedal

Ref. No.	Part No.	Part Name	Quantity	Remarks
35	92076-015	RUBBER—footrest	2	
36	34003-033	BAR—footrest	2	
37	92003-076	BOLT—L.H. footrest fitting	1	
38	315B1200A	NUT, 12 m/m	1	
39	92007-025	BOLT—R.H. footrest fitting	1	
40	461F1200	WASHER—spring, 12 m/m	1	
41	34028-010	BAR—rear footrest	2	
42	92076-020	RUBBER—rear footrest	2	
43	92022-199	WASHER—plain	2	
44	34029-008	BRACKET—rear footrest	2	
45	92043-079	PIN—rear footrest fitting	2	
46	550D2012	PIN—cotter, 2.0 x 12	2	
47	92026-074	SPACER	2	
48	410B1000	WASHER—plain, 10 m/m	3	
49	461F1000	WASHER—spring, 10 m/m	2	
50	313B1000	NUT, 10 m/m	2	

17. Front Fork (1/2)

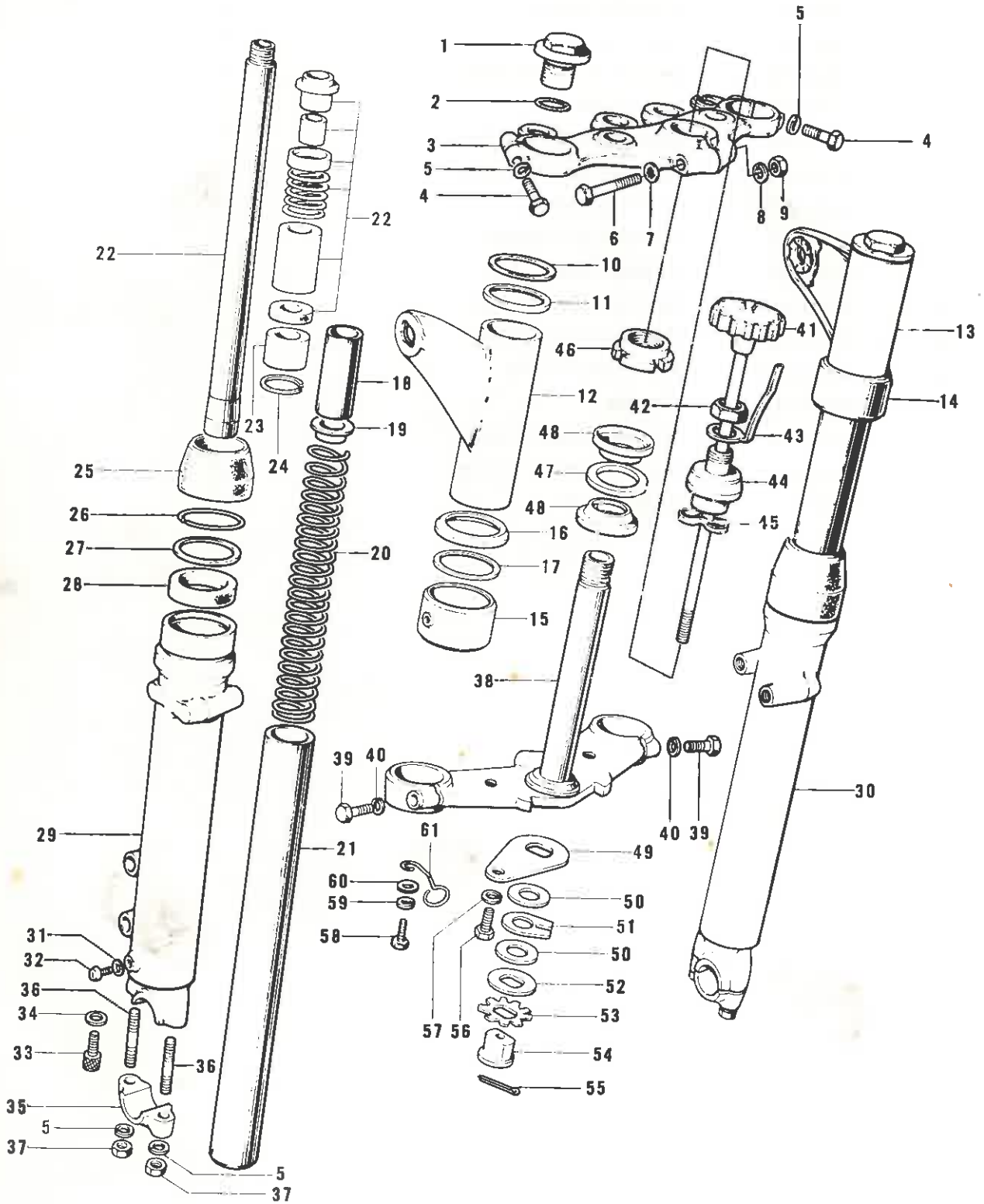

## 17. Front Fork (1/2)

Ref. No.	Part No.	Part Name	Quantity	Remarks
1 ~ 40	44001-097-21	FRONT FORK ASSY, Flat Black	1	To be modified locally for NEIMAN KEY SET
1	44041-037	BOLT—fork top	2	
2	44046-017	"O" RING—fork top bolt	2	
3	44039-051	HEAD—steering stem	1	
4	44041-044	BOLT—hex head, 8 x 30	2	
5	461F0800	WASHER—spring, 8 m/m	6	
6	44041-042	BOLT—hex head, 8 m/m	1	
7	463H0800	WASHER—lock, 8 m/m	1	
8	410B0800	WASHER—plain, 8 m/m	1	
9	92019-007	NUT, 8 m/m	1	
10	44045-039	GASKET—fork cover	2	
11	44043-047	GUIDE—fork cover	2	
12	44033-053-21	COVER—L.H. fork cover	1	Flat Black
13	44034-053-21	COVER—R.H. fork cover	1	Flat Black
14	44064-009	GUIDE—fork cover, R.H.	1	
15	44064-010	GUIDE—fork cover, L.H.	1	
16	44032-005	GUIDE—fork cover	2	
17	44045-029	GASKET—fork cover	2	
18	44028-026	SPACER—fork spring guide	2	
19	44029-019	GUIDE—fork spring	2	
20	44026-043	SPRING—fork	2	
21	44013-038	TUBE—fork inner	2	
22	44022-011	CYLINDER—fork	2	
23	44018-001	PISTON—fork	2	
24	44044-008	CIRCLIP—fork piston	2	
25	44010-019	DUST SHIELD	2	
26	44044-005	CIRCLIP	2	
27	44043-023	WASHER—plain	2	
28	44009-013	OIL SEAL	2	
29	44005-046	TUBE—L.H. fork outer	1	
30	44006-044	TUBE—R.H. fork outer	1	
31	44045-002	GASKET—fork drain plug	2	
32	220B0408A	SCREW—pan head, 4 x 8	2	
33	44041-040	BOLT—fork cylinder	2	



17. Front Fork (2/2)

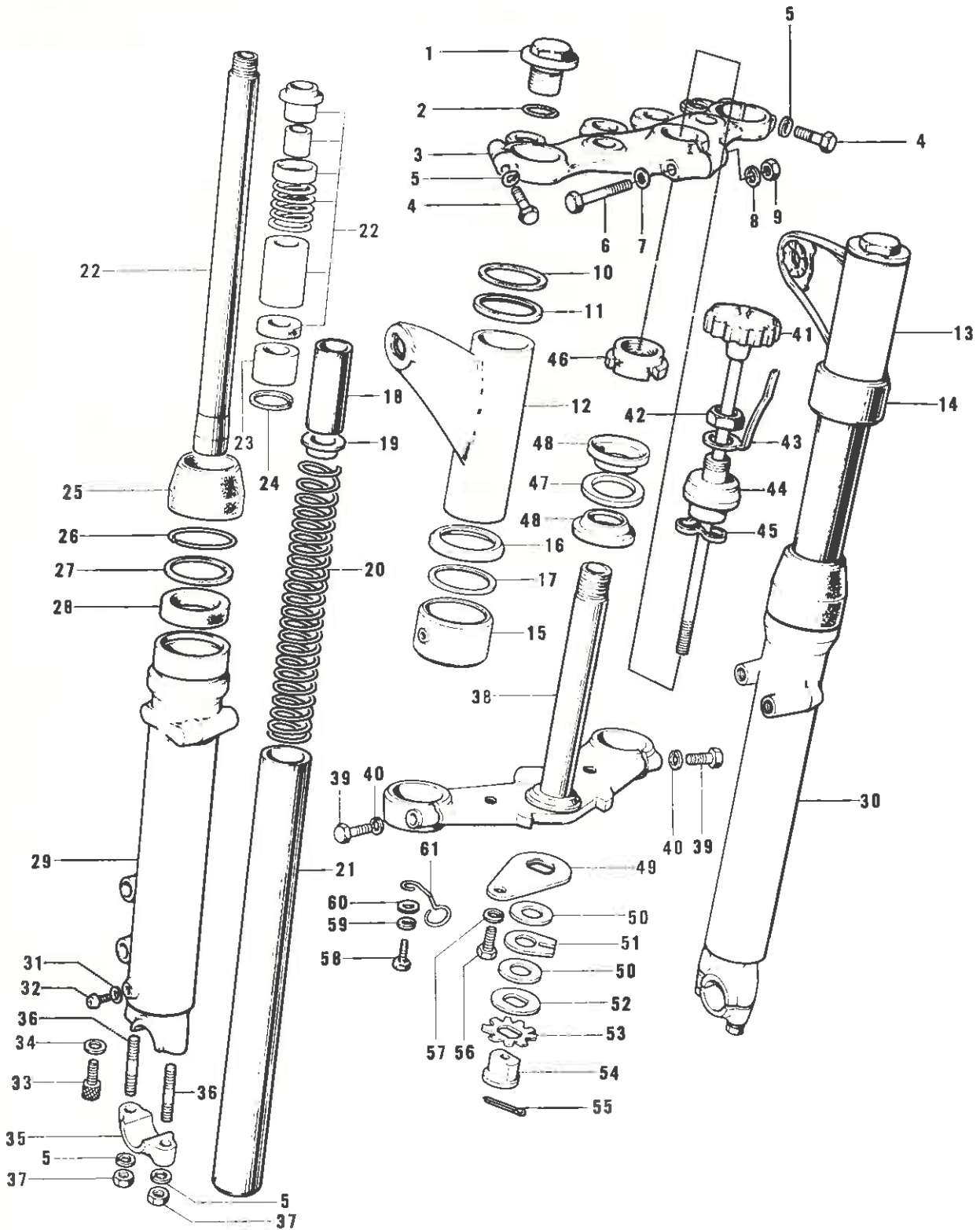

## 17. Front Fork (2/2)

Ref. No.	Part No.	Part Name	Quantity	Remarks
34	44045-034	GASKET—fork cylinder bolt	2	
35	44063-006	HOLDER—front axle	2	
36	172G0830	STUD, 8 x 30	4	
37	310B0800	NUT, 8 m/m	4	
38	44037-058	STEM—steering	1	To be modified locally for NEIMAN KEY SET
39	113B1032	BOLT—hex head, 10 x 32	2	
40	461F1000	WASHER—spring, 10 m/m	2	
41	46101-007	KNOB—steering damper	1	
42	315N1200A	NUT, 12 m/m	1	
43	46126-001	SPRING—steering damper	1	
44	92090-020	NUT—steering stem	1	
45	46100-002	WASHER—wave	1	
46	92090-007	NUT—steering stem lock	1	
47	46098-010	CAP—steering stem	1	
48	92047-006	CONE—steering stem bearing	2	
49	46106-007	PLATE—steering damper steel	1	
50	46104-005	PLATE—steering damper friction	2	
51	46105-005	PLATE—steering damper anchor	1	
52	46106-008	PLATE—steering damper steel	1	
53	46124-006	SPRING—steering damper	1	
54	46125-005	NUT—steering damper guide	1	
55	550D1615	PIN—cotter, 1.6 x 15	1	
56	114B0812	BOLT—hex head, 8 x 12	1	
57	461F0800	WASHER—spring, 8 m/m	1	
58	110B0610	BOLT—hex head, 6 x 10	1	
	116B0610	BOLT—hex head, 6 x 10	ALT	
59	461F0600	WASHER—spring, 6 m/m	1	
60	410B0600	WASHER—plain, 6 m/m	1	
61	92037-099	CLAMP—cable	1	

18. Fenders

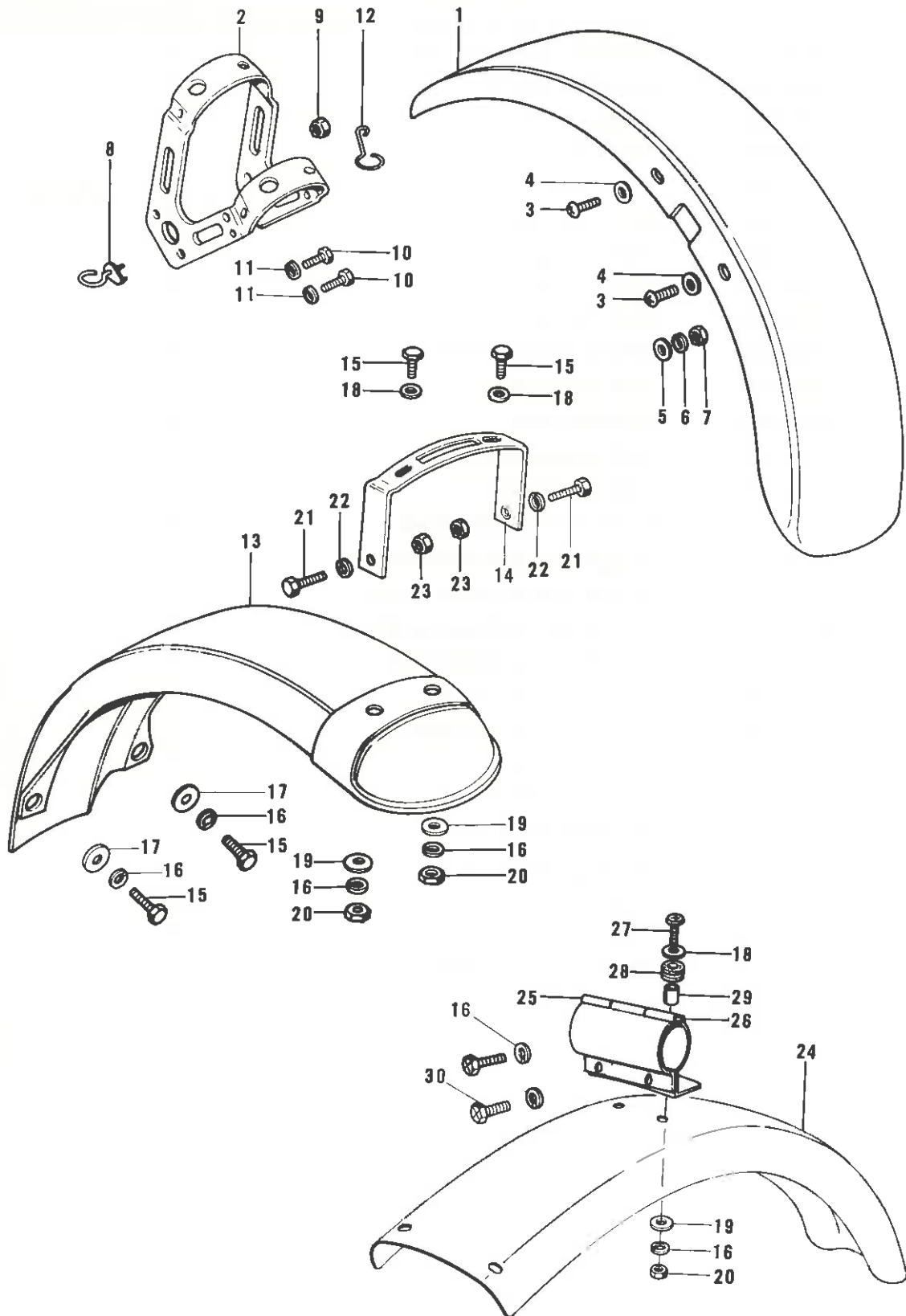

## 18. Fenders

Ref. No.	Part No.	Part Name	Quantity	Remarks
1	35004-075	FENDER—front	1	Cr-Plated
2	35009-024	BRACE—front fender	1	Cr-Plated
3	220E0614	SCREW—pan head, 6 x 14	4	
4	92022-193	WASHER—plain	4	
5	411B0600	WASHER—plain, 6 m/m	4	
6	461F0600	WASHER—spring, 6 m/m	4	
7	310B0600	NUT, 6 m/m	4	
8	92037-097	CLAMP	1	
9	92019-014	NUT—lock, 4 m/m	1	
10	110B0816	BOLT—hex head, 8 x 16	4	
11	461F0800	WASHER—spring, 8 m/m	4	
12	92037-096	CLAMP—cable	1	
13	35022-056	FENDER A—rear	1	
14	35025-021	BRACKET—rear fender	1	
15	110B0618	BOLT—hex head, 6 x 18	4	
	116B0618	BOLT—hex head, 6 x 18	ALT	
16	461F0600	WASHER—spring, 6 m/m	8	
17	92027-122	COLLAR	2	
18	92022-125	WASHER—plain, 6 m/m	4	
19	411B0600	WASHER—plain, 6 m/m	4	
20	310B0600	NUT, 6 m/m	4	
21	113N1025	BOLT—hex head, 10 x 25	2	
22	461F1000	WASHER—spring, 10 m/m	2	
23	313B1000	NUT, 10 m/m	2	
24	35022-077	FENDER B—rear	1	
25	35025-023	BRACKET—rear fender	1	
26	32111-003	PIN—oil tank	1	
27	220E0620	SCREW—pan head, 6 x 20	2	
28	92075-076	DAMPER RUBBER	2	
29	92027-129	COLLAR	2	
30	220E0612	SCREW—pan head, 6 x 12	2	

19. Tires, Rims

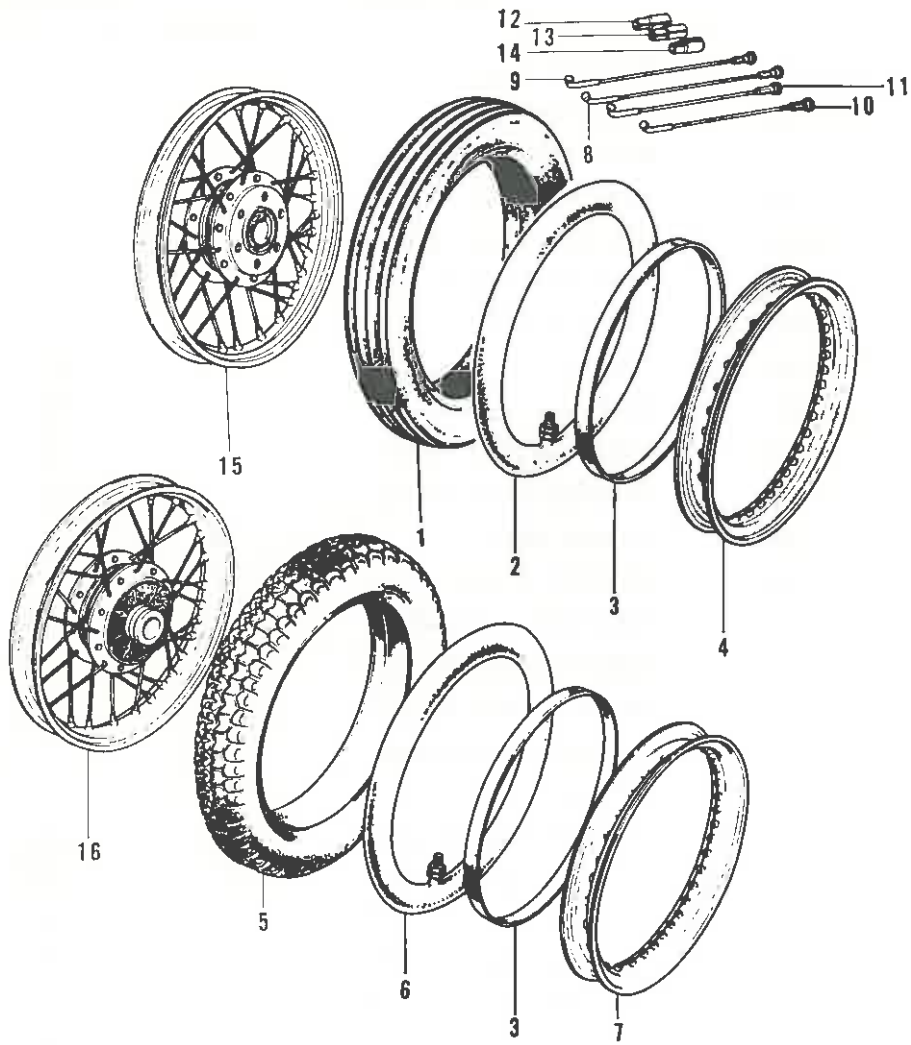

21. Rear Hub

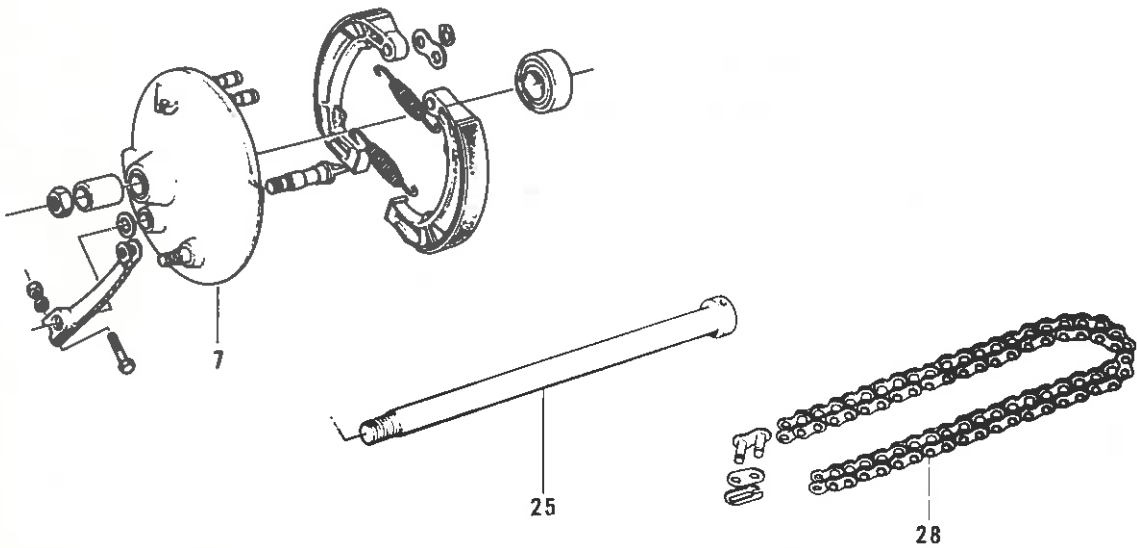

## 19. Tires, Rims

Ref. No.	Part No.	Part Name	Quantity	Remarks
1	41013-013	TIRE—front, 3.00-18 4PR	1	Y506
2	41022-020	TUBE—tire, 3.00-18	1	
3	41023-017	BAND—rim	2	
4	41025-061	RIM, 1.60A x 18W	1	
5	41014-023	TIRE—rear, 3.50-18 4PR	1	Y622
6	41022-027	TUBE—tire, 3.50-18	1	
7	41025-053	RIM, 1.85B x 18W	1	
8	41027-054	SPOKE ASSY—front inner	20	102° x 174.5 m/m
9	41028-054	SPOKE ASSY—front outer	20	83° x 174 m/m
10	41027-046	SPOKE ASSY—rear inner	20	104° x 147 m/m
11	41028-045	SPOKE ASSY—rear outer	20	85° x 146 m/m
12	41075-001	WEIGHT—balance, 10g	AR	
13	41075-002	WEIGHT—balance, 20g	AR	
14	41075-003	WEIGHT—balance, 30g	AR	
15	41074-030	WHEEL ASSY—front	1	1.60A x 18
16	42048-017	WHEEL ASSY—rear	1	1.85B x 18W

## 21. Rear Hub

Ref. No.	Part No.	Part Name	Quantity	Remarks
7 ~ 16, 32	42006-007-80	PANEL ASSY—rear brake	1	Buff Finish
25	42031-033	AXLE—rear	1	
28, 29	695X5098	CHAIN ASSY—drive	1	EK530SH

20. Front Hub

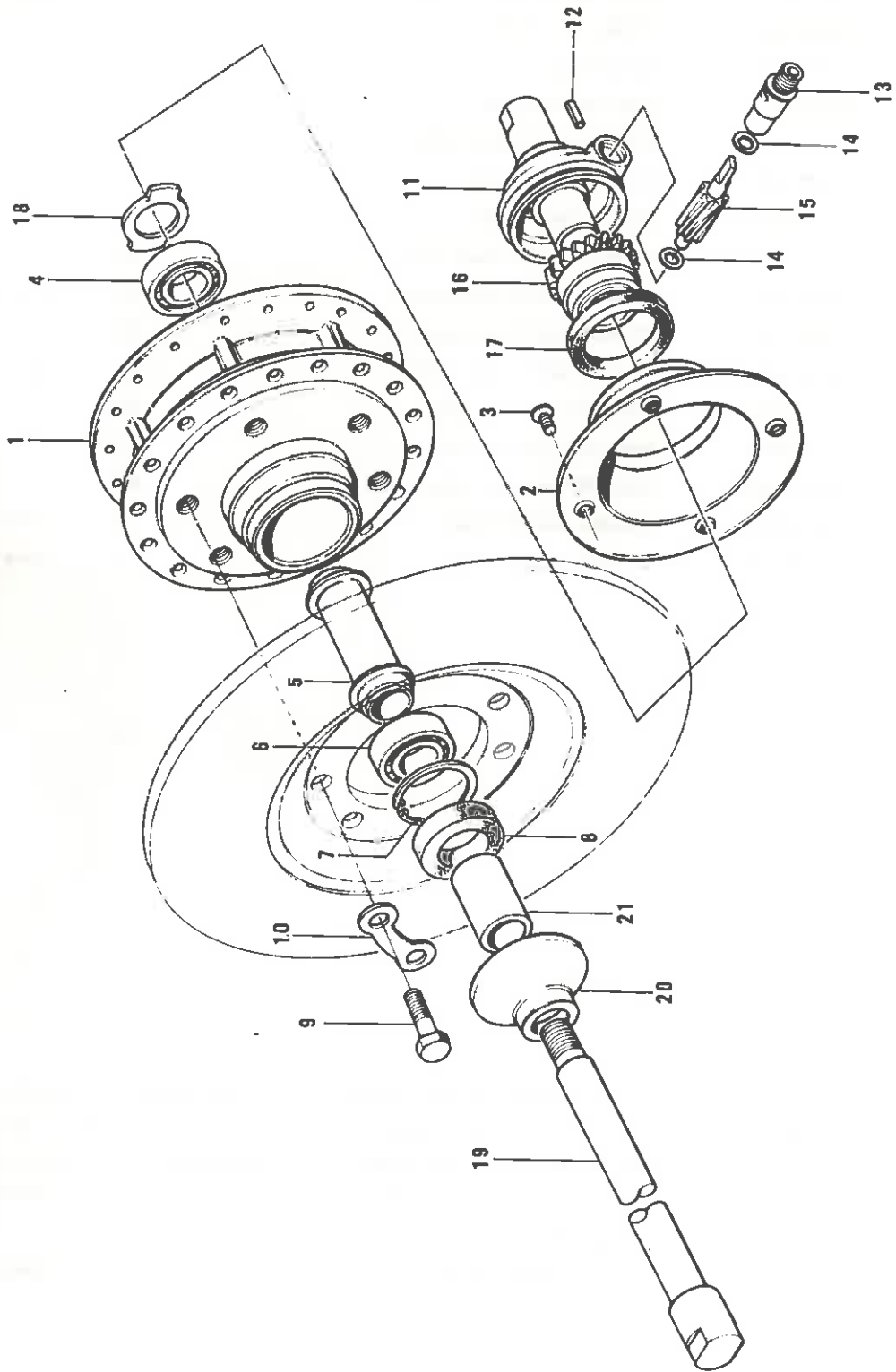

## 20. Front Hub

Ref. No.	Part No.	Part Name	Quantity	Remarks
1 ~ 10	41034-024	DRUM ASSY—front brake	1	
2	41042-011	DUST COVER	1	
3	222E0408A	SCREW—pan head, 4 x 8	4	
4	601B6302Z	BEARING—ball, #6302Z	1	
5	41039-021	SPACER—front axle bearing	1	
6	601B6302	BEARING—ball, #6302	1	
7	481J4200	CIRCLIP, 42 m/m	1	
8	92052-005	OIL SEAL	1	
9	92001-104	BOLT—hex head, 8 x 28	4	
10	92088-016	WASHER—lock	2	
11 ~ 18	41078-002	GEAR BOX ASSY	1	
12	41082-001	SPRING PIN	1	
13	41062-005	BUSHING—speedometer cable	1	
14	41063-001	WASHER—thrust	2	
15	<del>41060-013</del> N.L.	PINION—speedometer	1	
16	41059-017 N.L.	GEAR—speedometer	1	25T
17	92050-049	OIL SEAL	1	
18	41064-008	RECEIVER—gear	1	
19	41068-038	AXLE—front	1	
20	41042-012	DUST COVER	1	
21	41069-020	COLLAR—front axle	1	



22. Fuel Tank

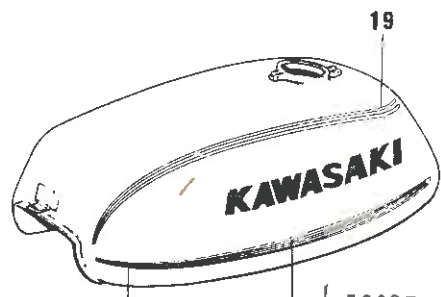
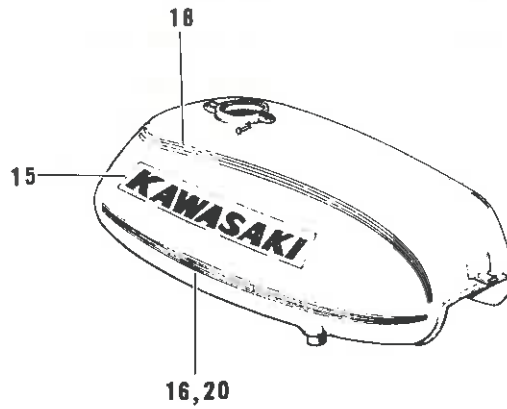
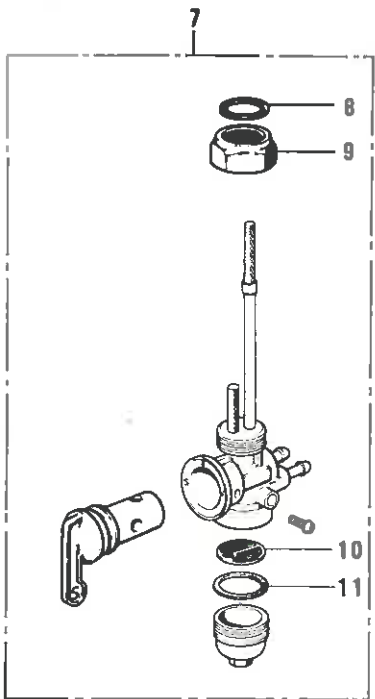
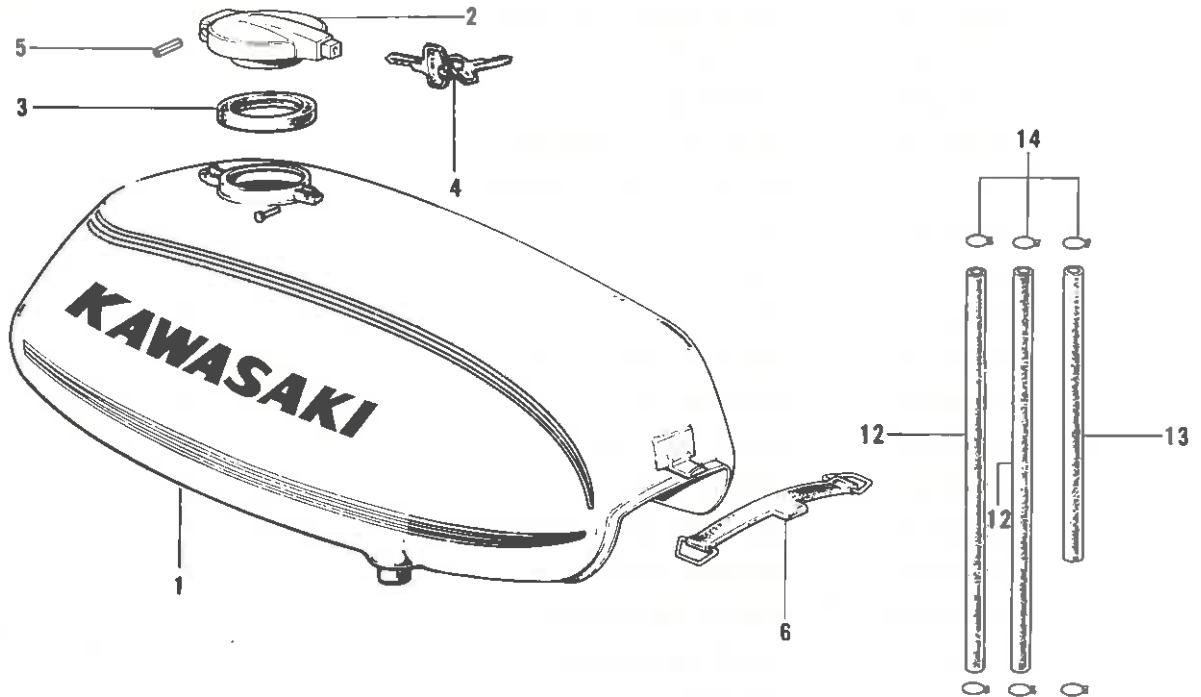

- |             |   |           |
|-------------|---|-----------|
| Orange-Red  | { | 56027-121 |
|             |   | 56027-122 |
| Blue Purple | { | 56027-133 |
|             |   | 56027-134 |

## 22. Fuel Tank

Ref. No.	Part No.	Part Name	Quantity	Remarks
1	51001-080-91	TANK—fuel, '72 Candytone Orange	1	
	51001-080-93	TANK—fuel, '72 Candytone Blue	1	
2 ~ 4	51049-020	CAP—fuel tank	1	
3	51059-008	GASKET—fuel tank cap	1	
4	27018-016-65	KEY SET, #265	1	
	27018-016-66	KEY SET, #266	1	
	27018-016-67	KEY SET, #267	1	
	27018-016-68	KEY SET, #268	1	
	27018-016-69	KEY SET, #269	1	
	27018-016-70	KEY SET, #270	1	
	27018-016-71	KEY SET, #271	1	
	27018-016-72	KEY SET, #272	1	
	27018-016-73	KEY SET, #273	1	
	27018-016-74	KEY SET, #274	1	
	27018-016-75	KEY SET, #275	1	
	27018-016-76	KEY SET, #276	1	
	27018-016-77	KEY SET, #277	1	
	27018-016-78	KEY SET, #278	1	
	27018-016-79	KEY SET, #279	1	
5	92043-094	PIN—fuel tank cap fitting	1	
6	92072-050	BAND—fuel tank	1	
7	51023-026	COCK ASSY—fuel	1	
8	92065-081	GASKET—fuel cock joint	1	
9	51035-009	NUT—fuel cock joint	1	
10	51038-007	STRAINER—fuel	1	
11	51037-010	GASKET—fuel cock cup	1	
12	92059-073	PIPE—fuel	2	L=220 m/m
13	92059-068	PIPE—fuel	1	L=130 m/m
14	92037-010	CLAMP—fuel pipe	6	
15	*56013-051	DECAL—fuel tank	2	} Transfer Type
16	*56027-133	DECAL—fuel tank stripe, L.H.	1	
17	*56027-134	DECAL—fuel tank stripe, R.H.	1	
18	*56027-123	DECAL—top fuel tank stripe, L.H.	1	
19	*56027-124	DECAL—top fuel tank stripe, R.H.	1	
20	*56027-121	DECAL—fuel tank stripe, L.H.	1	
21	*56027-122	DECAL—fuel tank stripe, R.H.	1	

\*Special Solution is required for these transfer type marks.

23. Oil Tank, Side Cover, Chain Cover

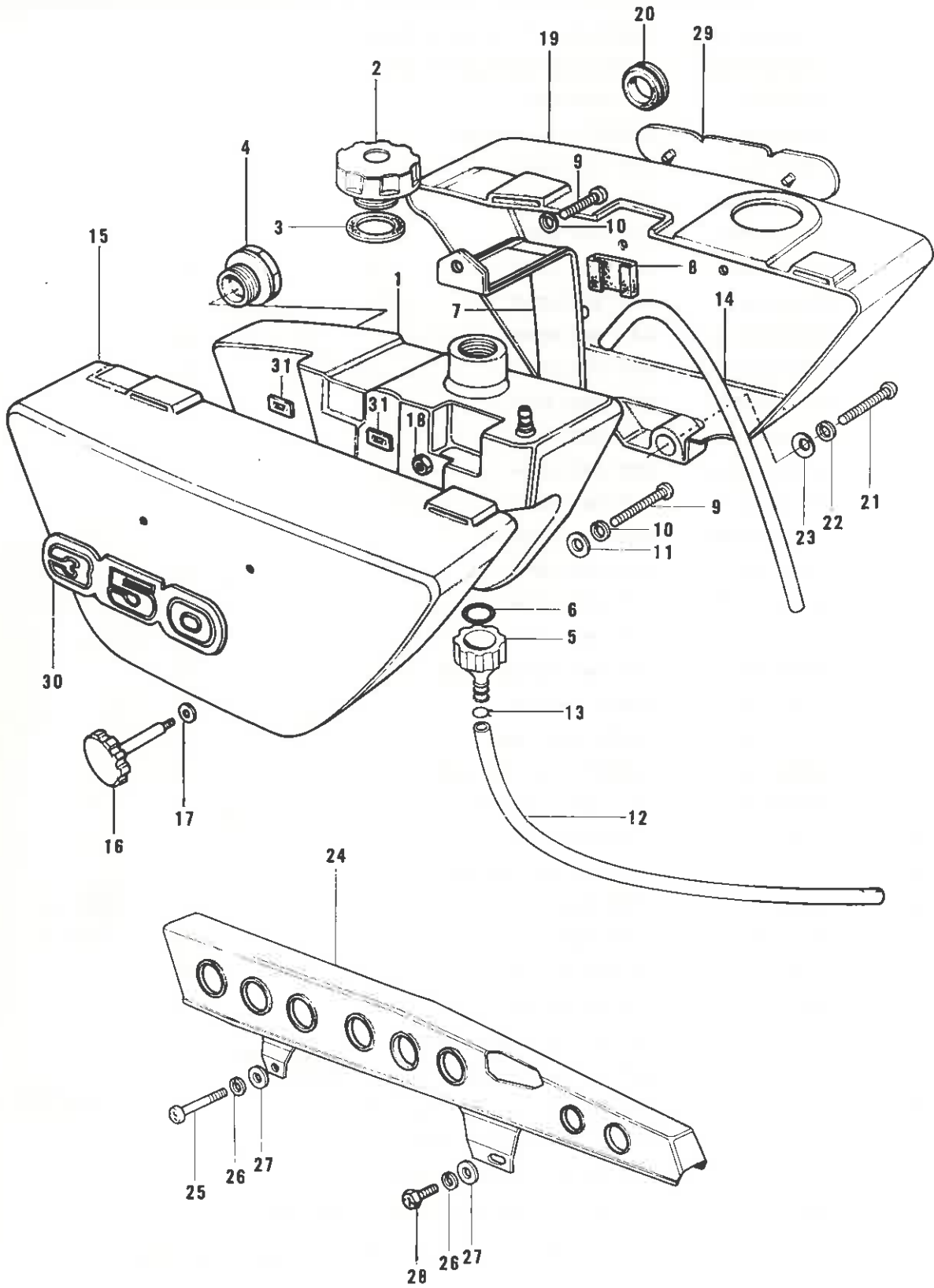

## 23. Oil Tank, Side Cover, Chain Cover

Ref. No.	Part No.	Part Name	Quantity	Remarks
1	52001-033	TANK—oil	1	
2	52003-020	CAP—oil tank	1	
3	92065-086	GASKET—oil tank cap	1	
4	52015-005	GAUGE—oil level	1	
5	52020-001	FILTER—oil	1	
6	670B2015	“O” RING, 15 m/m	1	
7	52018-002	BAND—oil tank	1	
8	31082-010	DAMPER RUBBER—oil tank band	2	
9	220B0614	SCREW—pan head, 6 x 14	2	
10	461F0600	WASHER—spring, 6 m/m	2	
11	411B0600	WASHER—plain, 6 m/m	1	
12	92059-072	PIPE—oil	1	
13	92037-010	CLAMP	2	
14	700Q05600	TUBE—vinyl, 5 x 600	1	
15	36001-039-91	COVER—L.H. side, '72 Candytone Orange	1	
	36001-039-93	COVER—L.H. side, '72 Candytone Blue	1	
16	92077-020	KNOB—side cover	1	
17	92075-041 N/L	DAMPER RUBBER—side cover	1	
18	312B0600	NUT, 6 m/m	1	
19	36007-031-91	COVER—R.H. side, '72 Candytone Orange	1	
	36007-031-93	COVER—R.H. side, '72 Candytone Blue	1	
20	92071-065	GROMMET—side cover	1	
21	220E0635	SCREW—pan head, 6 x 35	1	
22	461F0600	WASHER—spring, 6 m/m	1	
23	411D0600	WASHER—plain, 6 m/m	1	
24	36014-040-21	COVER—chain, Flat Black	1	
25	220E0655	SCREW—pan head, 6 x 55	1	
26	461F0600	WASHER—spring, 6 m/m	2	
27	92022-193	WASHER—plain	2	
28	92001-121	BOLT—hex head, 6 x 14	1	
29	56018-135	EMBLEM—R.H. side cover	1	
30	56018-136	EMBLEM—L.H. side cover	1	
31	92018-003	NUT—lock	4	

24. Dual Seat (1/2)

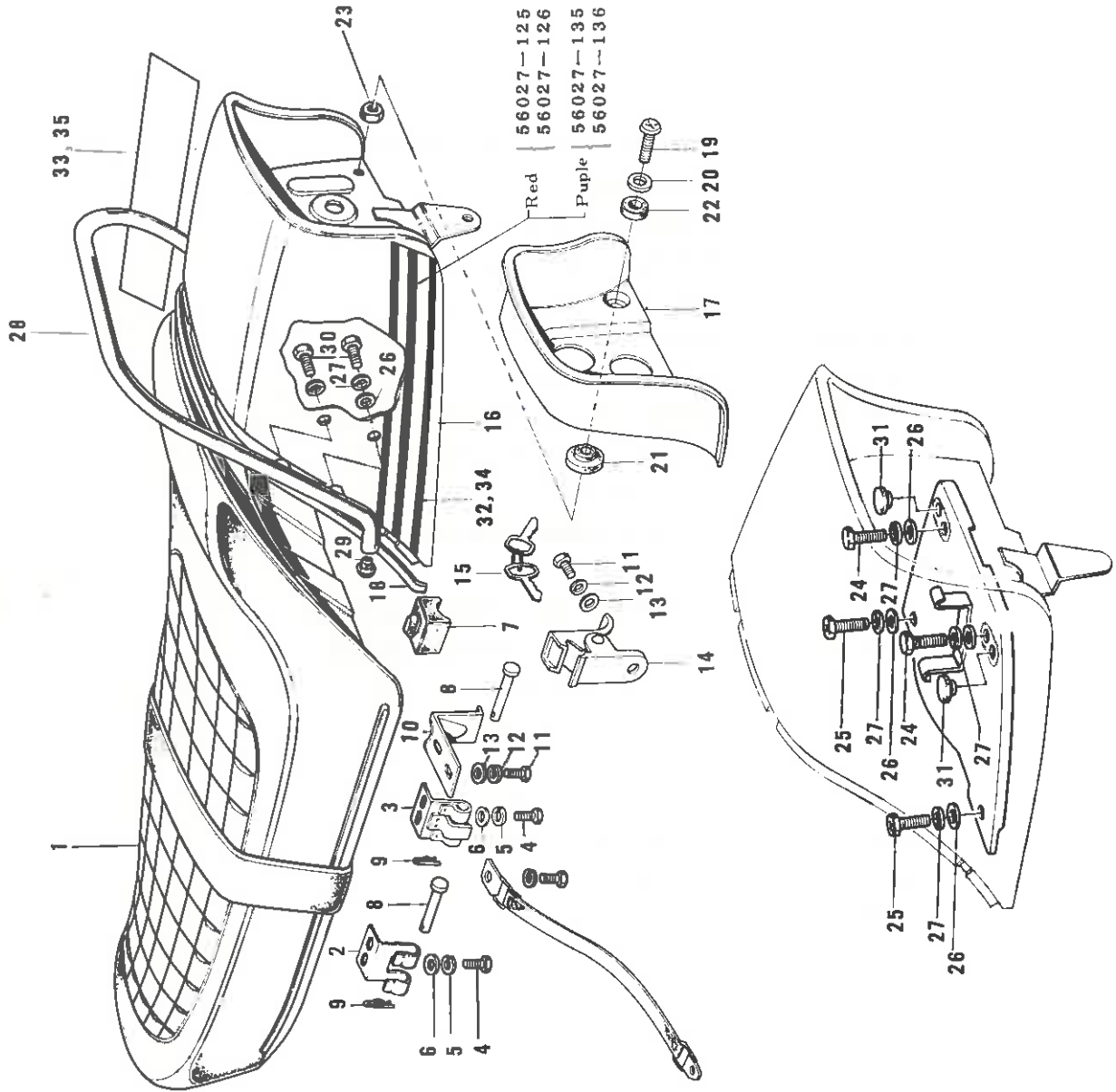

## 24. Dual Seat (1/2)

Ref. No.	Part No.	Part Name	Quantity	Remarks
1 ~ 7	53001-080	SEAT ASSY—dual	1	
2	53009-017	HINGE A	1	
3	53009-021	HINGE B	1	
4	110B0614	BOLT—hex head, 6 x 14	4	
	116B0614	BOLT—hex head, 6 x 14	ALT	
5	461F0600	WASHER—spring, 6 m/m	4	
6	411B0600	WASHER—plain, 6 m/m	4	
7	92075-156	DAMPER RUBBER—dual seat	5	
8	53011-002	PIN—dual seat pivot	2	
9	92041-003	COTTER PIN	2	
10	53008-011	HOOK	1	
11	110B0614	BOLT—hex head, 6 x 14	3	
	116B0614	BOLT—hex head, 6 x 14	ALT	
12	461F0600	WASHER—spring, 6 m/m	3	
13	411B0600	WASHER—plain, 6 m/m	3	
14, 15	53045-003	HOOK ASSY	1	
15	27018-016-65	KEY SET, #265	1	
	27018-016-66	KEY SET, #266	1	
	27018-016-67	KEY SET, #267	1	
	27018-016-68	KEY SET, #268	1	
	27018-016-69	KEY SET, #269	1	
	27018-016-70	KEY SET, #270	1	
	27018-016-71	KEY SET, #271	1	
	27018-016-72	KEY SET, #272	1	
	27018-016-73	KEY SET, #273	1	
	27018-016-74	KEY SET, #274	1	
	27018-016-75	KEY SET, #275	1	
	27018-016-76	KEY SET, #276	1	
	27018-016-77	KEY SET, #277	1	
	27018-016-78	KEY SET, #278	1	
	27018-016-79	KEY SET, #279	1	
16	53043-005-91	BACK REST, '72 Candytone Orange	1	
	53043-005-93	BACK REST, '72 Candytone Blue	1	
17	53057-001	COVER—back rest	1	
18	53044-003	MOLE	1	

24. Dual Seat (2/2)

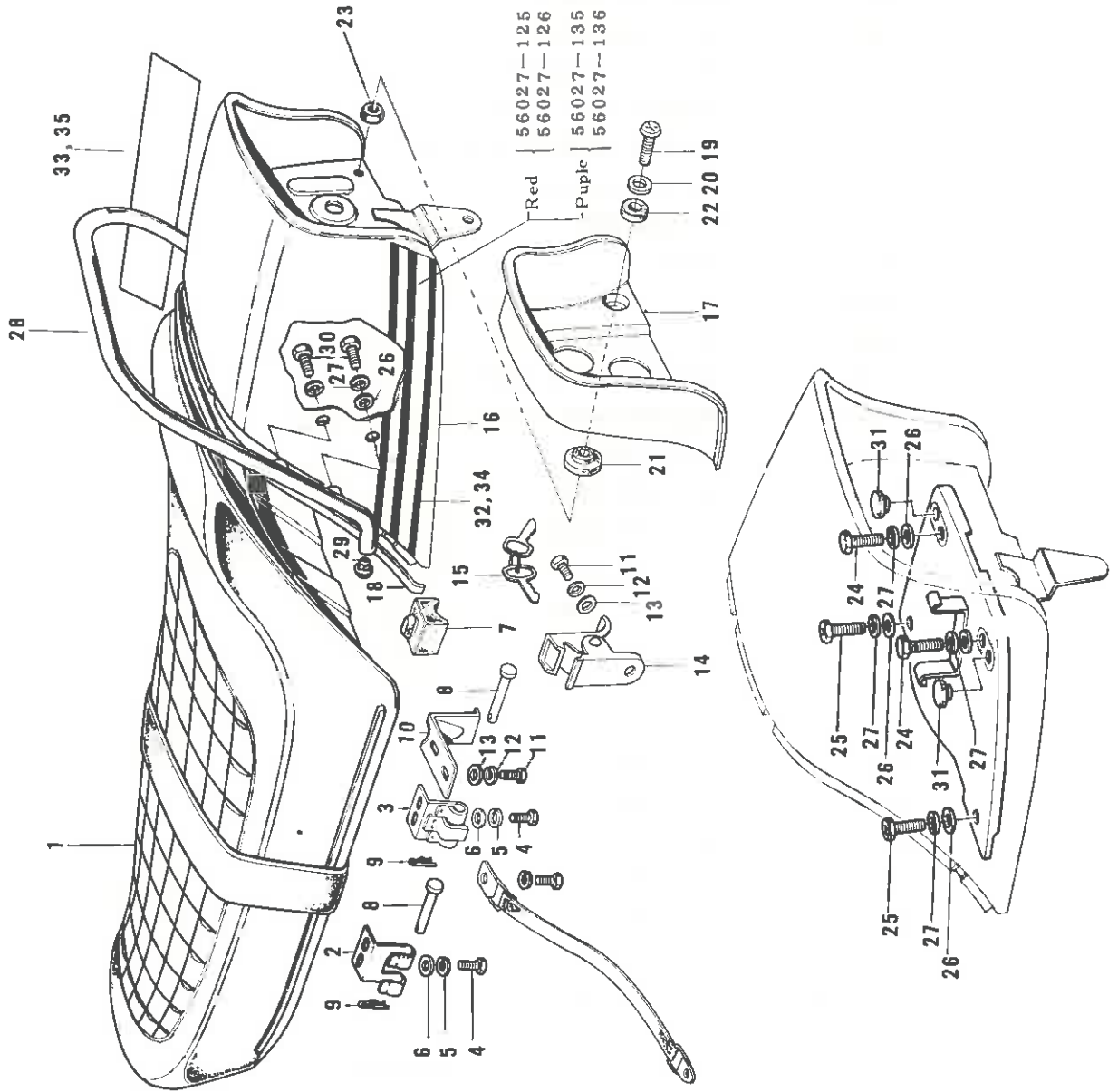

## 24. Dual Seat (2/2)

Ref. No.	Part No.	Part Name	Quantity	Remarks
19	92011-030	SCREW—pan head, 6 x 30	4	
20	92022-240	WASHER—plain	4	
21	92075-169	DAMPER RUBBER B—back rest cover	4	
22	92075-168	DAMPER RUBBER A—back rest cover	4	
23	311B0600	NUT, 6 m/m	4	
24	110B0816	BOLT—hex head, 8 x 16	2	
25	92001-122	BOLT—hex head, 8 x 16	2	
26	411B0800	WASHER—plain, 8 m/m	6	
27	461F0800	WASHER—spring, 8 m/m	8	
28	53042-005	GRIP—seat	1	
29	32112-005	PLUG—seat grip	2	
30	110B0812	BOLT—hex head, 8 x 12	4	
31	92068-007	PLUG	2	
32	*56027-135	DECAL—back rest stripe, L.H.	1	} Transfer Type
33	*56027-136	DECAL—back rest stripe, R.H.	1	
34	*56027-125	DECAL—back rest stripe, L.H.	1	
35	*56027-126	DECAL—back rest stripe, R.H.	1	

\*Special solution is required for these transfer type marks.



25. Cables

---

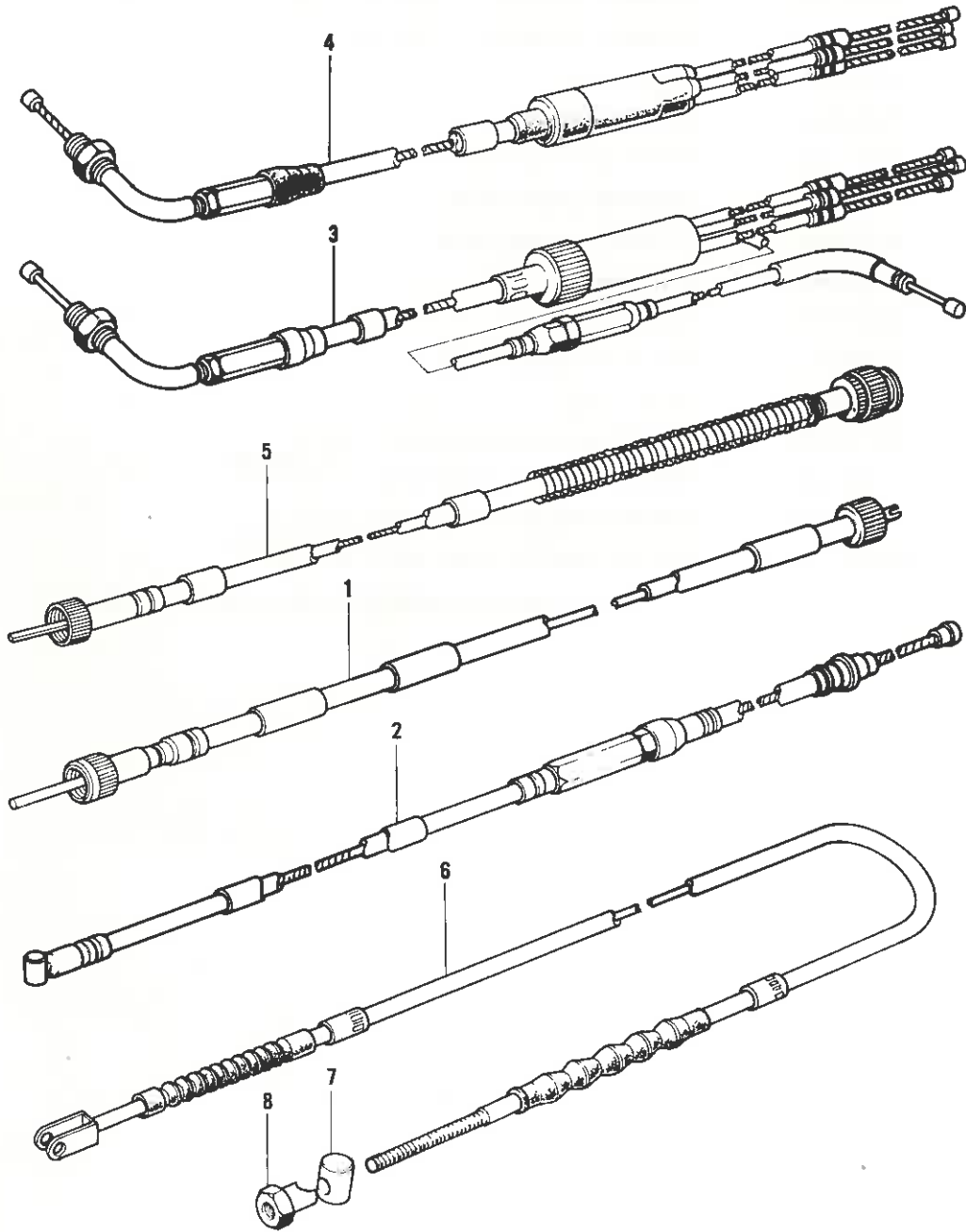

## 25. Cables

Ref. No.	Part No.	Part Name	Quantity	Remarks
1	54001-041	CABLE—speedometer	1	
2	54011-049	CABLE—clutch	1	
3	54012-084	CABLE—combination	1	
4	54017-052	CABLE—starter	1	
5	54018-016	CABLE—tachometer	1	
6 ~ 8	54022-021 <i>NL</i>	CABLE—rear brake	1	
7	92043-053	JOINT—brake cable	2	
8	92015-041	NUT—brake cable adjusting	2	

26-1. Electrical Equipment A

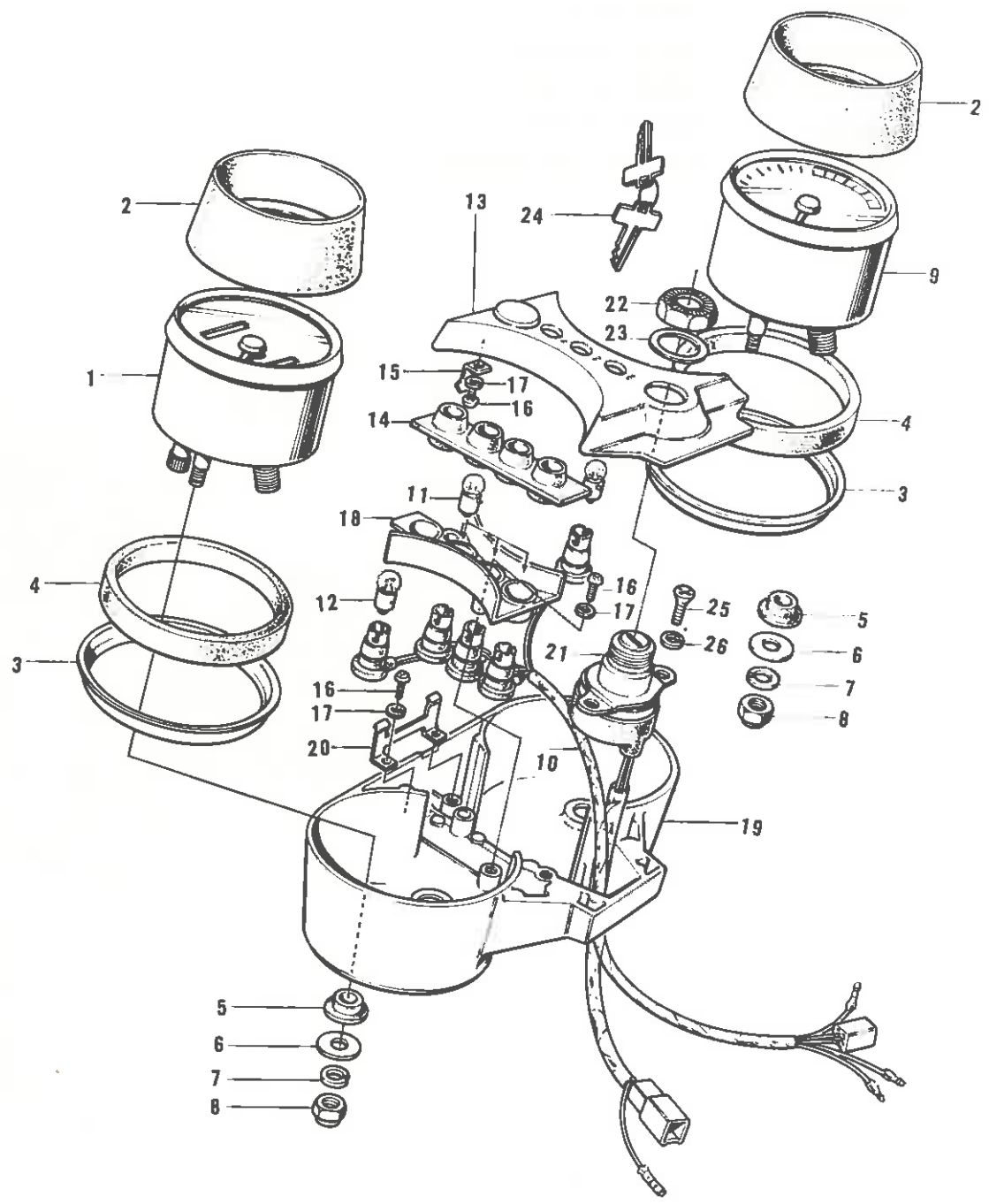

## 26-1. Electrical Equipment A

Ref. No.	Part No.	Part Name	Quantity	Remarks
1 ~ 8	25005-074	SPEEDOMETER ASSY, MPH	1	
	25005-076	SPEEDOMETER ASSY, KPH	1	
2	25012-012	COVER—meter	2	
3	25026-001	RING—meter	2	
4	25019-015	DAMPER RUBBER—meter	2	
5	25019-013	DAMPER RUBBER—meter case fitting	4	
6	411B0500	WASHER—plain, 5 m/m	4	
7	461E0500	WASHER—spring, 5 m/m	4	
8	92015-059	NUT, 5 m/m	4	
2 ~ 9	25016-020	TACHOMETER ASSY	1	
10	25011-029	SOCKET—meter	1	
11	92069-017	BULB, 12V 1.5W	1	
12	92069-018	BULB, 12V 3W	5	
13	25023-002	COVER—meter case	1	
14	25019-014	DAMPER—meter shock	1	
15	25014-004	HOLDER B—meter case cover	2	
16	220B0408A	SCREW—pan head, 4 x 8	6	
17	461F0400	WASHER—spring, 4 m/m	6	
18	25023-003	COVER—meter socket	1	
19	25008-026	CASE—meter	1	
20	25014-003	HOLDER A—meter case	1	
21 ~ 24	27005-047	SWITCH ASSY—ignition	1	
22	27007-003	NUT—ignition switch	1	
23	27019-002	WASHER—ignition switch	1	
24	27008-048-86	KEY SET, #186	1	
	27008-048-87	KEY SET, #187	1	
	27008-048-88	KEY SET, #188	1	
	27008-048-89	KEY SET, #189	1	
	27008-048-90	KEY SET, #190	1	
25	220B0508A	SCREW—pan head, 5 x 8	2	
26	461F0500	WASHER—spring, 5 m/m	2	

26-2. Electrical Equipment B

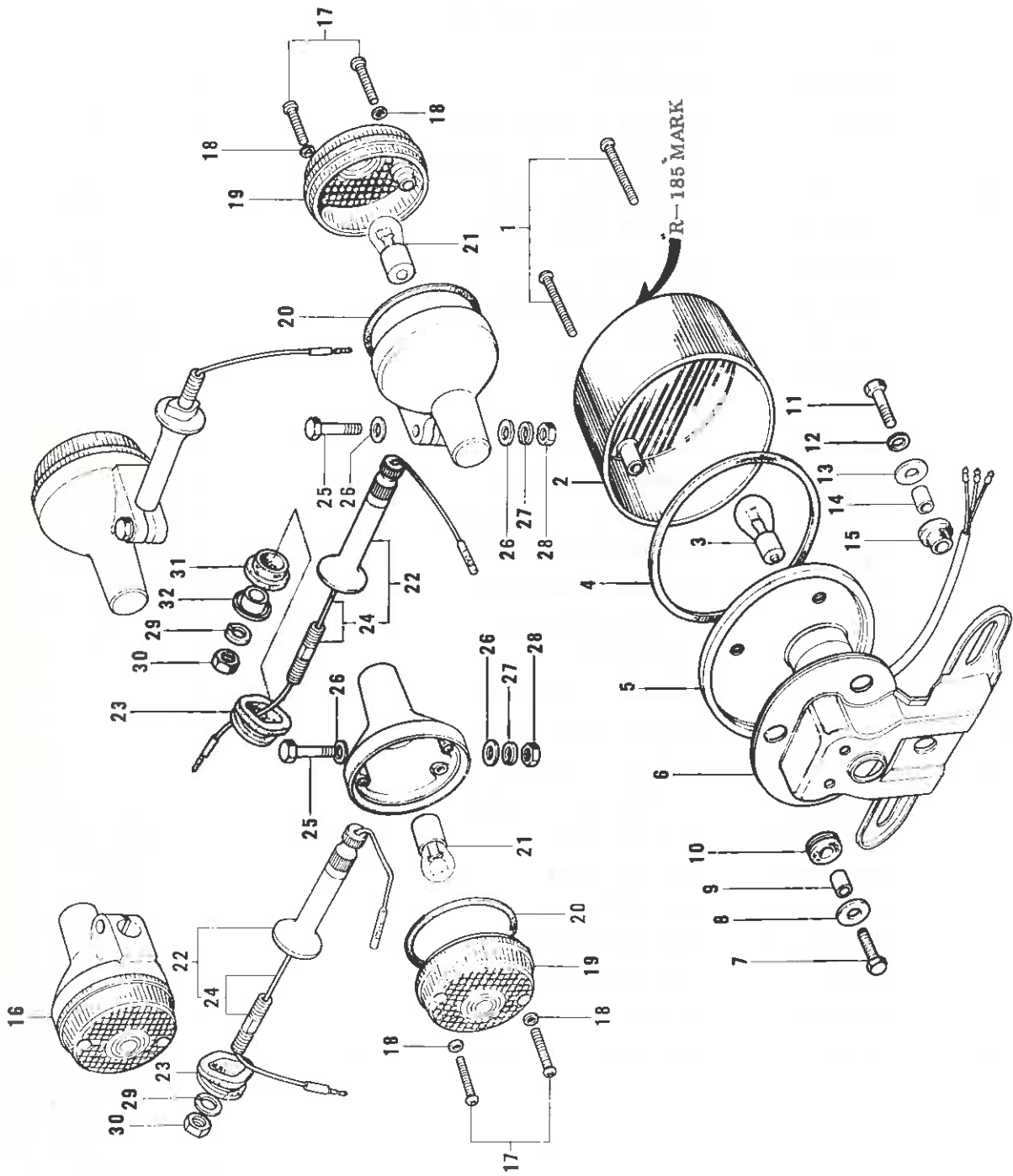

## 26-2. Electrical Equipment B

Ref. No.	Part No.	Part Name	Quantity	Remarks
1 ~ 10	23024-030-21	LAMP ASSY—tail	1	Flat Black
1	220E0435A	SCREW—pan head, 4 x 35	2	
2	23026- <del>027</del> 1073	LENS—tail lamp	1	
3	92069-063	BULB, 12V 21/5W	1	
4	23028-018	GASKET—tail lamp	1	
5	23027-036	CASE—tail lamp	1	
6	23036-027-21	BRACKET—license plate	1	Flat Black
7	110B0622	BOLT—hex head, 6 x 22	3	
	116B0622	BOLT—hex head, 6 x 22	ALT	
8	92022-125	WASHER—plain	3	
9	92027-129	COLLAR	3	L=8.5 m/m
10	92075-076	DAMPER RUBBER	3	
11	110B0622	BOLT—hex head, 6 x 22	3	
	116B0622	BOLT—hex head, 6 x 22	ALT	
12	461F0600	WASHER—spring, 6 m/m	3	
13	92022-125	WASHER—plain	3	
14	92027-120	COLLAR	3	L=10.5 m/m
15	92075-112	DAMPER RUBBER	3	
16	23040-037	LAMP ASSY—turn signal	4	
17	220E0420A	SCREW—pan head, 4 x 20	8	
18	23058-002	WASHER—plain, 4 m/m	8	
19	23048-013	LENS—turn signal lamp	4	
20	23050-003	GASKET—turn signal lamp lens	4	
21	92069-055	BULB, 12V 32CP	4	
22	23078-001	BRACKET—turn signal lamp	4	
23	92075-128	DAMPER RUBBER	4	
24	23073-001	BOLT SET—signal lamp bracket	4	
25	116N0630	BOLT—hex head, 6 x 30	4	
26	410D0600	WASHER—plain, 6 m/m	8	
27	461F0600	WASHER—spring, 6 m/m	4	
28	310N0600	NUT, 6 m/m	4	
29	461F1000	WASEHR—spring, 10 m/m	4	
30	315B1000	NUT, 10 m/m	4	
31	92075-158	DAMPER RUBBER	2	
32	92027-147	COLLAR	2	

26-3. Electrical Equipment (German Type)

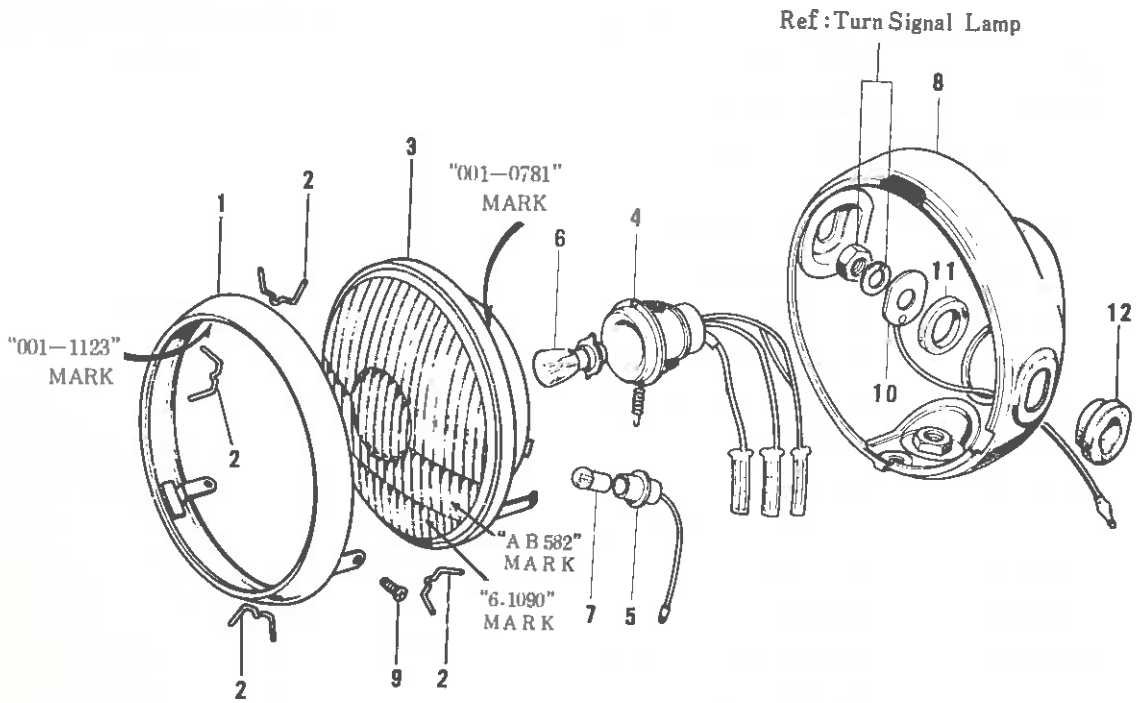

26-4. Electrical Equipment (French Type)

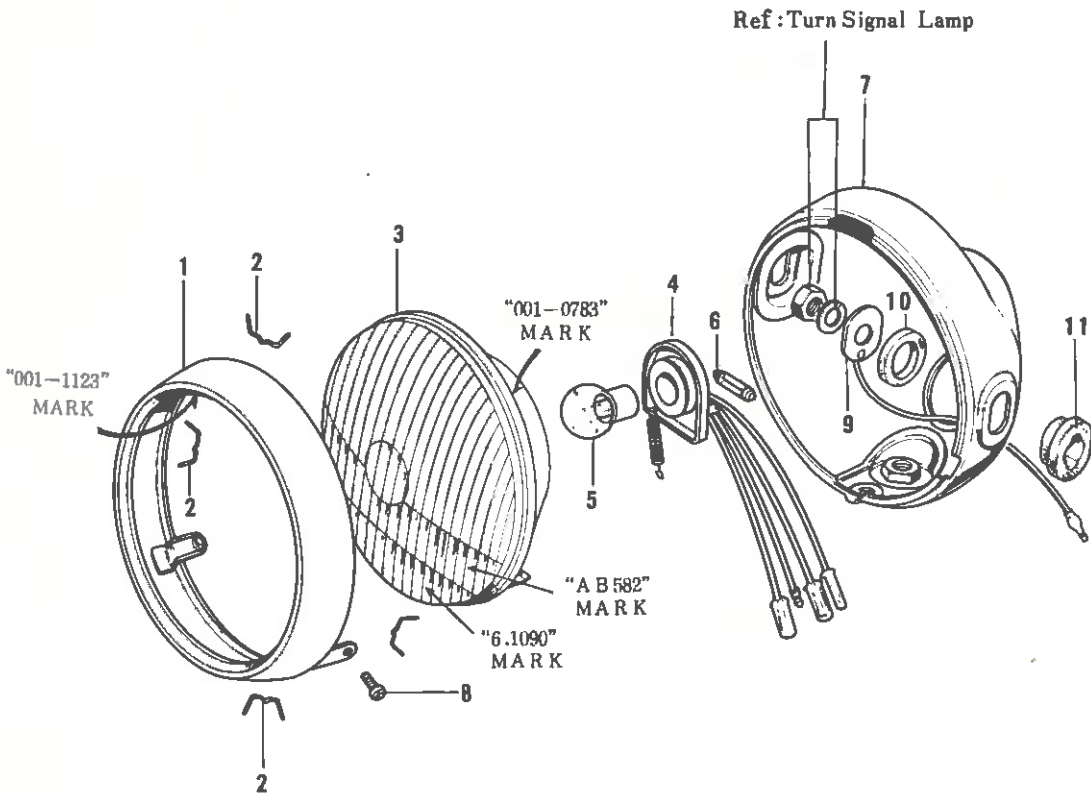

## 26-3. Electrical Equipment (German Type)

Ref. No.	Part No.	Part Name	Quantity	Remarks
1 ~ 7	23004-043	LAMP UNIT—head	1	
1	23006-036	RIM—head lamp	1	
2	23009-013	CLAMP—head lamp lens unit	4	
3	23007-042	LENS UNIT—head lamp	1	
4	23008-035	SOCKET—head lamp	1	
5	23008-036	SOCKET—parking lamp	1	
6	92069-069	BULB, 12V 35/35W	1	
7	92069-071	BULB, 12V 4W	1	
8	23005-038-21	BODY—head lamp, Flat Black	1	
9	23019-022	SCREW—pan head, 5 m/m	2	
10	23076-001	COLLAR SET	2	
11	23066-001	DAMPER RUBBER A	2	
12	23066-005	DAMPER RUBBER B	2	

## 26-4. Electrical Equipment (French Type)

Ref. No.	Part No.	Part Name	Quantity	Remarks
1 ~ 6	23004-044	LAMP UNIT—head	1	
1	23006-036	RIM—head lamp	1	
2	23009-013	CLAMP—head lamp lens unit	4	
3	23007-047	LENS UNIT—head lamp	1	
4	23008-034	SOCKET—head lamp	1	
5	92069-070	BULB, 12V 36/36W	1	
6	92069-072	BULB, 12V 4W	1	
7	23005-038-21	BODY—head lamp, Flat Black	1	
8	23019-022	SCREW—pan head, 5 m/m	2	
9	23076-001	COLLAR SET	2	
10	23066-001	DAMPER RUBBER A	2	
11	23066-005	DAMPER RUBBER B	2	



27. Electrical Equipment C

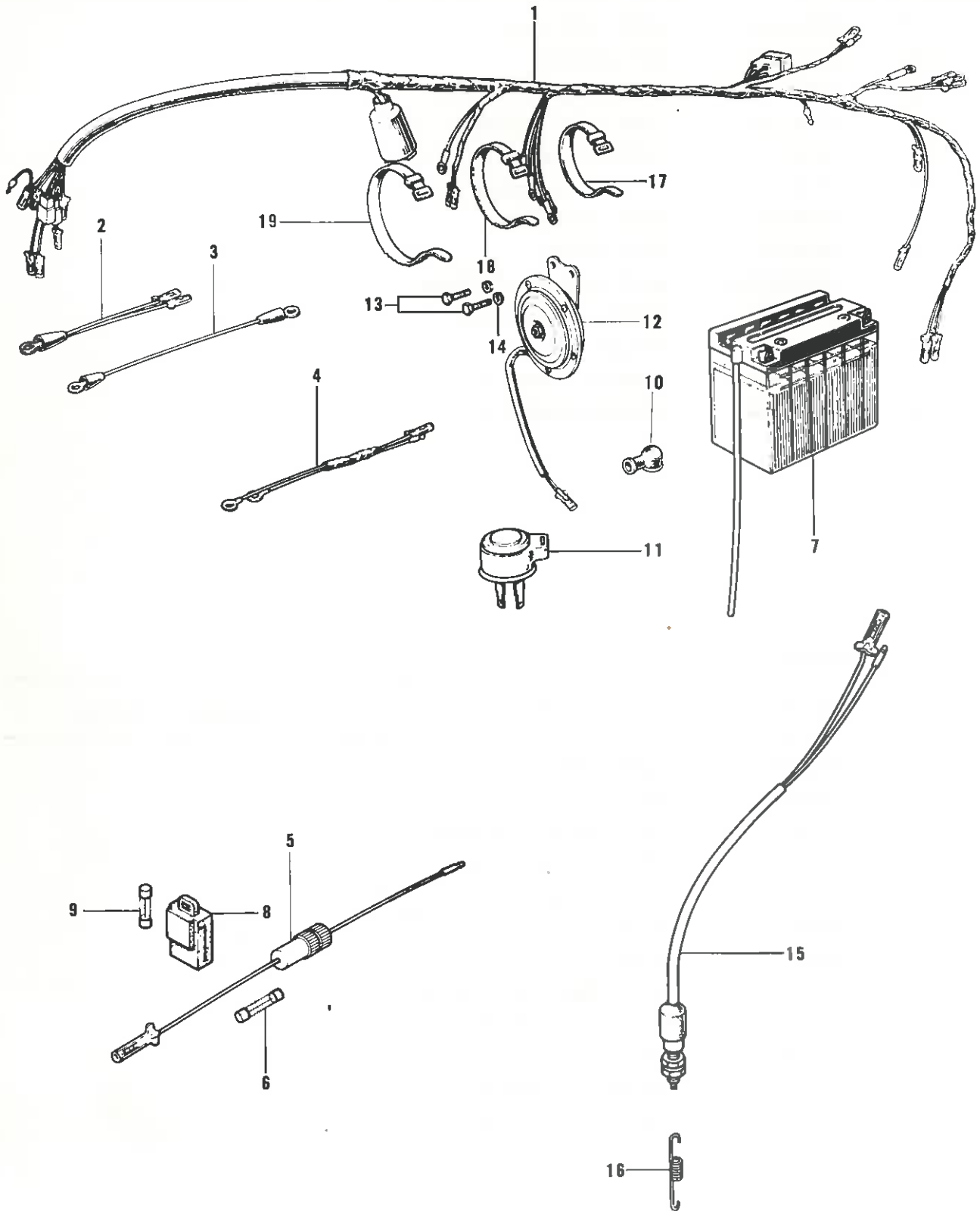

## 27. Electrical Equipment C

Ref. No.	Part No.	Part Name	Quantity	Remarks
1	26001-081	WIRING HARNESS—main	1	
2	26010-015	WIRE—lead	1	
3	26010-017	WIRE—battery ground	1	
4	26011-064	WIRE—signal lamp lead	1	
5, 6	26004-015	FUSE ASSY	1	
6	26006-005	FUSE, 20A	1	
7	26012-022	BATTERY, 12V 6AH	1	
8	26016-004	HOLDER—spare fuse	1	
9	26006-005	FUSE, 20A	1	
10	92073-001	RUBBER CAP—battery	1	
11	27002-011	RELAY—turn signal	1	
12	27003-026	HORN	1	
13	116B0816	BOLT—hex head, 8 x 16	2	
14	461F0800	WASHER—spring, 8 m/m	2	
15	27010-020	SWITCH—brake lamp	1	
16	27011-013	SPRING—brake lamp switch	1	
17	92072-030	BAND, short	5	
18	92072-031	BAND, middle	1	
19	92072-032	BAND, large	1	

30. Disc Brake Equipment A

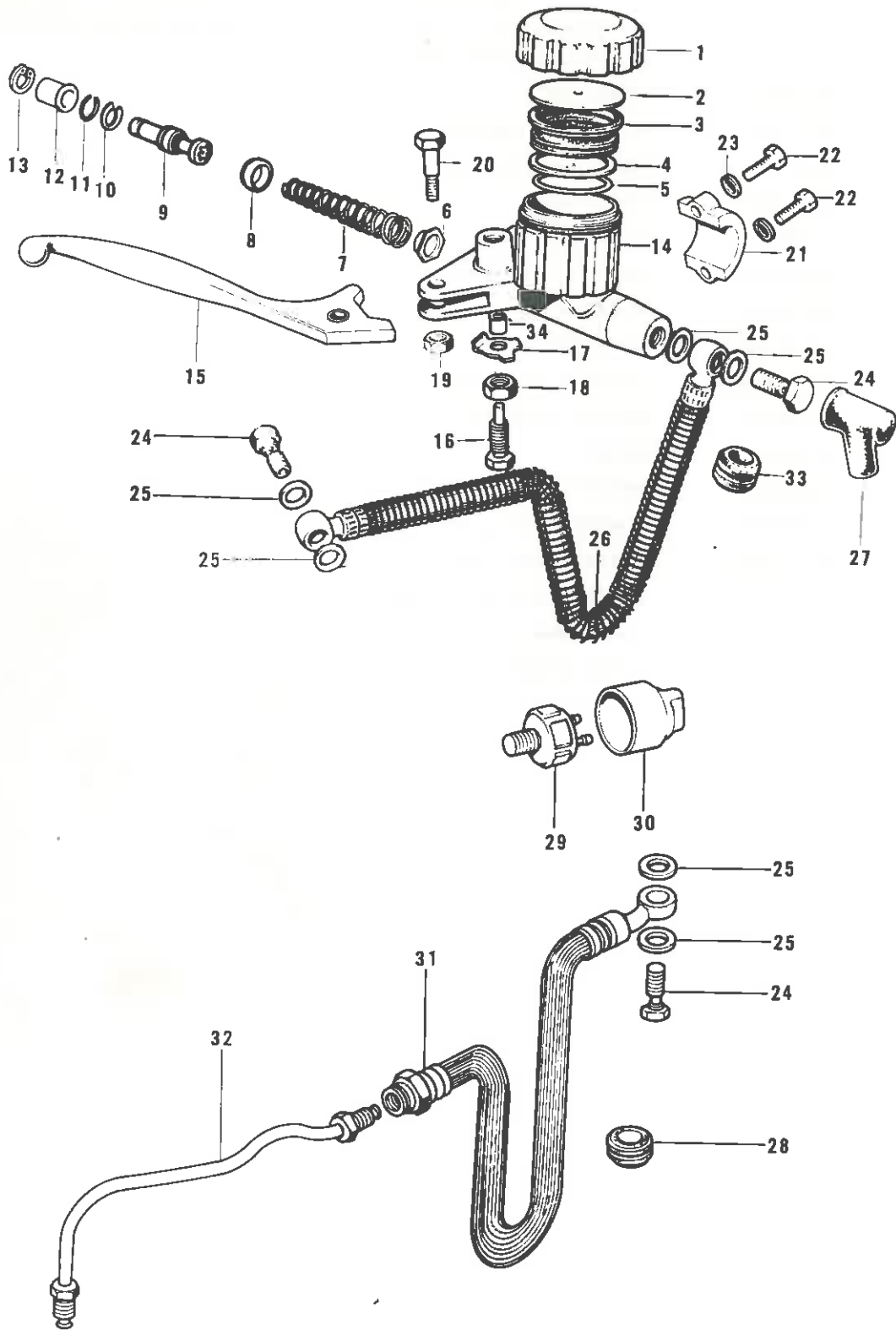

## 30. Disc Brake Equipment A

Ref. No.	Part No.	Part Name	Quantity	Remarks
1 ~ 23	43015-003	CYLINDER ASSY—master	1	
1	43026-001	CAP—oil cup	1	
2	43027-001	PLATE—diaphragm	1	
3	43028-001	DIAPHRAGM	1	
4	43053-003	RING—seal	1	
5	43079-001	“O” RING	1	
6 ~ 13	43073-001	REPAIR SET—master cylinder	1	
6	43017-001	VALVE ASSY—check	1	
7	43018-001	SPRING ASSY—return	1	
8	43019-001	CUP—primary	1	
9	43072-001	PISTON ASSY	1	
10	43022-001	STOPPER	1	
11	481J1800	CIRCLIP, 18 m/m	1	
12	43024-001	DUST COVER	1	
13	43025-001	STOPPER—dust cover	1	
14	43016-003	CYLINDER—master	1	
15	43029-001	LEVER—front brake	1	
16	43030-002	BOLT—lever adjust	1	
17	43031-001	WASHER—lock	1	
18	312N0600	NUT, 6 m/m	1	
19	313N0800	NUT, 8 m/m	1	
20	43033-001	BOLT—handle lever pivot	1	
21	43034-001	HOLDER—master cylinder	1	
22	110N0625	BOLT—hex head, 6 x 25	2	
23	410B0600	WASHER—plain, 6 m/m	2	
24	43066-001	BOLT—oil	3	
25	43067-001	WASHER—oil bolt	6	
26	43059-010	HOSE—master cylinder brake	1	
27	43069-001	DUST COVER	1	
28	43064-001	DAMPER RUBBER—brake hose	1	I.D=13.5φ
29	43065-001	SWITCH ASSY—front brake	1	
30	92073-023	RUBBER CAP—front brake switch	1	
31	43059-008	HOSE—calliper brake	1	
32	43060-008	PIPE—bridge	1	
33	43064-005	DAMPER RUBBER—brake hose	1	I.D=15 φ
34	43074-001	TUBE	1	

31. Disc Brake Equipment B

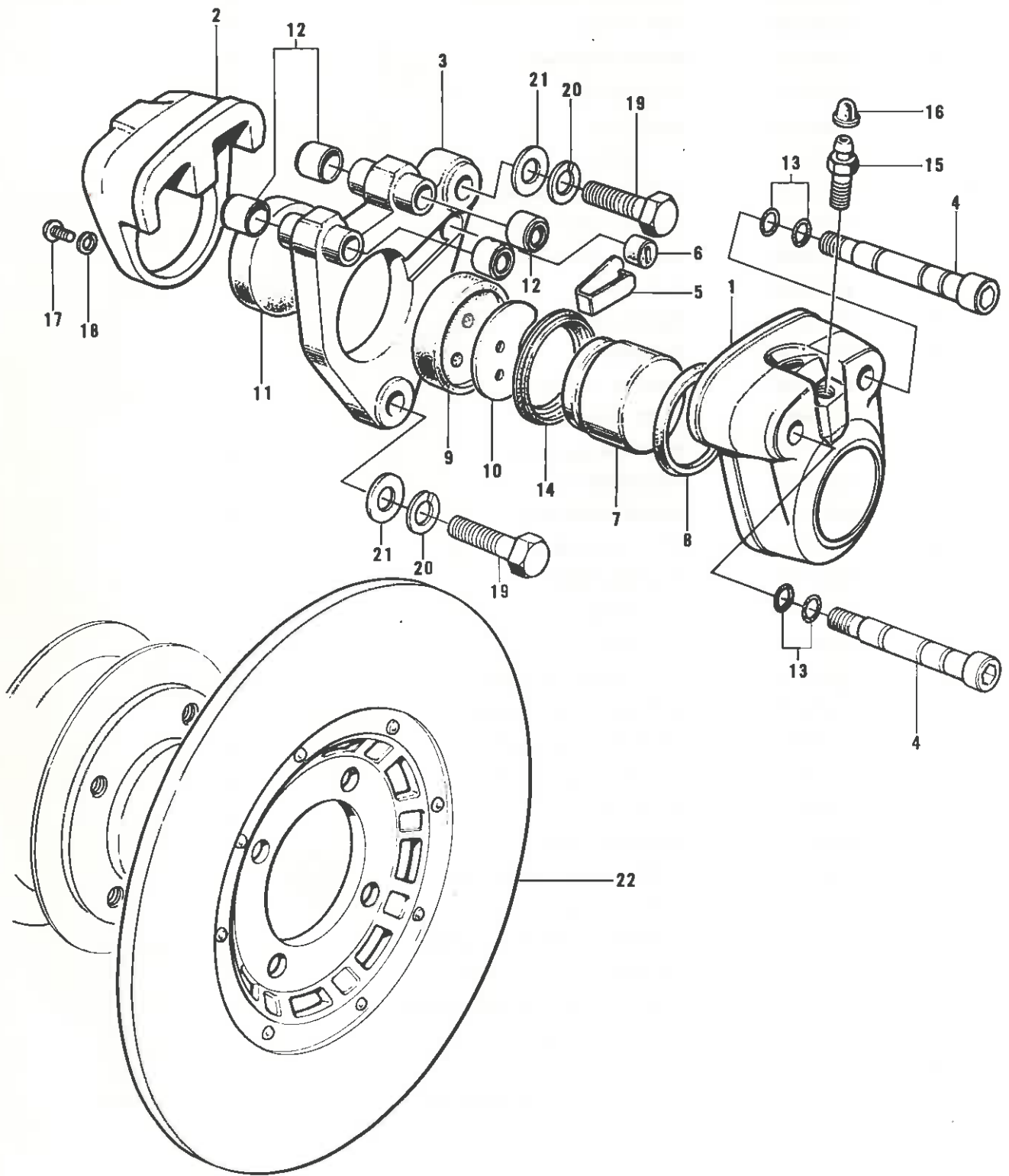

## 31. Disc Brake Equipment B

Ref. No.	Part No.	Part Name	Quantity	Remarks
1 ~ 18	43041-003	CALLIPER ASSY	1	
1	43042-003	CALLIPER A	1	
2	43043-002	CALLIPER B	1	
3	43044-003	HOLDER—calliper	1	
4	43045-002	SHAFT	2	
5	43046-001	STOPPER—pad	1	
6	43047-001	BUSHING—rubber	1	
7	43048-001	PISTON	1	
8, 12 ~ 14	43073-003	REPAIR SET—calliper	1	
8	43049-001	SEAL—piston	1	
9	43050-001	PAD A	1	
10	43076-001	SHIM	1	
11	43051-001	PAD B	1	
12	43052-002	DUST SHIELD—shaft	4	
13	43053-001	"O" RING	4	
14	43054-002	DUST SHIELD—rubber	1	
15	43056-002	BREEDER	1	
16	43057-002	CAP—breeder	1	
17	220B0612	SCREW—pan head, 6 x 12	1	
18	461F0600	WASHER—spring, 6 m/m	1	
19	92007-032	BOLT—hex head, 10 m/m	2	
20	461F1000	WASHER—spring, 10 m/m	2	
21	410B1000	WASHER—plain, 10 m/m	2	
22	41080-002	DISC COMPLETE	1	

## Numerical Parts Index (New Part No. Sequence)

\* : Indicates the Newly developed parts for Kawasaki 350 Model S2-A

Part No.	Part Name	Page	Quantity
* 11001-053-80	2	2	
13008-039	2	3	
13024-047	2	3	
13025-043	2	3	
13031-040	2	1	
13081-052	2	1	
13087-033	2	1	
13245-003	4	1	
* 14026-008-36	4	1	
14027-010-36	4	1	
14030-030-36	4	1	
* 14031-052-36	4	1	
* 14032-061-36	4	1	
16082-041	4	1	
16115-017	4	1	
21130-013	4	3	
21156-003	4	1	
21156-004	4	1	
21156-005	4	1	
* 23004-043	36	1	
* 23004-044	36	1	
* 23005-038-21	36	1	
* 23005-038-21	36	1	
* 23006-036	36	1	
* 23006-036	36	1	
* 23007-042	36	1	
* 23007-047	36	1	
23008-034	36	1	
23008-035	36	1	
23008-036	36	1	
23009-013	36	4	
23009-013	36	4	
23019-022	36	2	
23019-022	36	2	
* 23024-030-21	34	1	
* 23026-027	34	1	
* 23027-036	34	1	
23028-018	34	1	
* 23036-027-21	34	1	
* 23040-037	34	4	
23048-013	34	4	
23050-003	34	4	
23058-002	34	8	
23066-001	36	2	
23066-001	36	2	
* 23066-005	36	2	
* 23066-005	36	2	
* 23073-001	34	4	
* 23076-001	36	2	
* 23076-001	36	2	
* 23078-001	34	4	
* 25005-074	32	1	
* 25005-076	32	1	
* 25008-026	32	1	
* 25011-029	32	1	
* 25012-012	32	2	
* 25014-003	32	1	
* 25014-004	32	2	
* 25016-020	32	1	
* 25019-013	32	4	
* 25019-014	32	1	
* 25019-015	32	2	
* 25023-002	32	1	
* 25023-003	32	1	
* 25026-001	32	2	
* 26001-093	38	1	
26004-015	38	1	
26006-005	38	1	
26006-005	38	1	
26010-015	38	1	
26010-017	38	1	
* 26011-064	38	1	
26012-022	38	1	
* 26016-004	38	1	
27002-011	38	1	
27003-026	38	1	
* 27005-047	32	1	
* 27007-003	32	1	
* 27008-048-86	32	1	
* 27008-048-87	32	1	
* 27008-048-88	32	1	
* 27008-048-89	32	1	
* 27008-048-90	32	1	
27010-020	38	1	
27011-013	38	1	
27018-016-65	22	1	
27018-016-65	26	1	
27018-016-66	22	1	
27018-016-66	26	1	
27018-016-67	22	1	
27018-016-67	26	1	
27018-016-68	22	1	
27018-016-68	26	1	
27018-016-69	22	1	
27018-016-69	26	1	
27018-016-70	22	1	
27018-016-70	26	1	
27018-016-71	22	1	
27018-016-71	26	1	
27018-016-72	22	1	
27018-016-72	26	1	
27018-016-73	22	1	
27018-016-73	26	1	
27018-016-74	22	1	
27018-016-74	26	1	
27018-016-75	22	1	
27018-016-75	26	1	
27018-016-76	22	1	
27018-016-76	26	1	
27018-016-77	22	1	
27018-016-77	26	1	
27018-016-78	22	1	

## Numerical Parts Index (New Part No. Sequence)

\* : Indicates the Newly developed parts for Kawasaki 350 Model S2-A

Part No.		Part Name	Page	Quantity
27018-016-78	26	1	* 42006-007-80	18 1
27018-016-79	22	1	42031-033	18 1
27018-016-79	26	1	42048-C17	18 1
* 27019-002	32	1	43015-003	40 1
* 32002-061	6	1	43016-003	40 1
31082-010	24	2	43017-001	40 1
* 32109-013	6	1	43018-001	40 1
32111-003	16	1	43019-001	40 1
* 32112-005	28	2	43022-001	40 1
* 32122-006	6	1	43024-001	40 1
* 32132-C01	6	1	43025-001	40 1
* 33032-037	8	1	43026-C01	40 1
* 33033-C09	8	2	43027-001	40 1
34003-033	10	2	43028-C01	40 1
34028-C10	10	2	43029-001	40 1
34029-008	10	2	43030-002	40 1
* 35004-C75	16	1	43031-001	40 1
* 35009-024	16	1	43033-001	40 1
35022-056	16	1	43034-001	40 1
* 35022-077	16	1	* 43041-003	42 1
35025-021	16	1	* 43042-003	42 1
* 35025-023	16	1	* 43043-002	42 1
* 36001-039-91	24	1	* 43044-003	42 1
* 36001-039-93	24	1	* 43045-002	42 2
* 36007-C31-91	24	1	43046-001	42 1
* 36007-C31-93	24	1	43047-001	42 1
36014-040-21	24	1	43048-001	42 1
41013-C13	18	1	43049-001	42 1
41014-023	18	1	43050-002	42 1
41022-020	18	1	43051-001	42 1
41022-027	18	1	* 43052-002	42 4
41023-C17	18	2	43053-001	42 4
41025-053	18	1	43053-003	40 1
* 41025-C61	18	1	43054-C02	42 1
41027-046	18	20	* 43056-C02	42 1
* 41027-C54	18	20	* 43057-002	42 1
41028-045	18	20	* 43059-C08	40 1
* 41028-C54	18	20	* 43059-010	40 1
* 41034-024	20	1	* 43060-008	40 1
* 41039-021	20	1	43064-001	40 1
* 41042-C11	20	1	* 43064-005	40 1
* 41042-012	20	1	43065-001	40 1
* 41059-017	20	1	43066-001	40 3
* 41060-013	20	1	43067-001	40 6
41062-005	20	1	43069-001	40 1
41063-001	20	2	43072-C01	40 1
* 41064-C08	20	1	43073-001	40 1
* 41068-C38	20	1	43073-003	42 1
* 41069-C20	20	1	43074-001	40 1
* 41074-C30	18	1	43076-C01	42 1
41075-001	18		43079-001	40 1
41075-C02	18		* 44001-097-21	12 1
41075-C03	18		* 44005-C46	12 1
* 41078-C02	20	1	* 44006-044	12 1
* 41080-C02	42	1	44009-013	12 2
41082-C01	20	1	44010-019	12 2



## Numerical Parts Index (New Part No. Sequence)

\* Indicates the Newly developed parts for Kawasaki 350 Model S2-A

New Part No.	Old Part No.	Part Name	Page	Quantity	
* 44013-038	12	2	* 51001-080-91	22	1
44018-001	12	2	* 51001-080-93	22	1
* 44022-011	12	2	51023-026	22	1
* 44026-043	12	2	51035-009	22	1
* 44028-026	12	2	51037-010	22	1
44029-019	12	2	51038-007	22	1
44032-005	12	2	51049-020	22	1
* 44033-053-21	12	1	51059-008	22	1
* 44034-053-21	12	1	* 52001-033	24	1
* 44037-058	14	1	52003-020	24	1
* 44039-051	12	1	* 52015-005	24	1
44041-037	12	2	52018-002	24	1
44041-040	12	2	52020-001	24	1
44041-042	12	1	* 53001-080	26	1
44041-044	12	2	53008-011	26	1
44043-023	12	2	53009-017	26	1
44043-047	12	2	* 53009-021	26	1
44044-005	12	2	53011-002	26	2
44044-008	12	2	* 53042-005	28	1
44045-002	12	2	* 53043-005-91	26	1
44045-029	12	2	* 53043-005-93	26	1
44045-034	14	2	* 53044-003	26	1
44045-039	12	2	53045-003	26	1
44046-017	12	2	* 53057-001	26	1
* 44063-006	14	2	* 54001-041	30	1
* 44064-009	12	1	* 54011-049	30	1
* 44064-010	12	1	* 54012-084	30	1
45014-062	8	2	* 54017-052	30	1
45016-003	8	2	* 54018-016	30	1
45017-001	8	4	54022-021	30	1
45017-007	8	2	56002-020	8	1
* 46006-011	8	1	56003-009	8	1
46018-018	8	1	56013-051	22	2
46019-023	8	1	* 56018-135	24	1
* 46031-008	8	1	* 56018-136	24	1
46043-006	8	1	* 56027-121	22	1
46044-014	8	1	* 56027-122	22	1
* 46076-027	8	1	* 56027-123	22	1
* 46080-005	8	1	* 56027-124	22	1
* 46082-027	8	1	* 56027-125	28	1
* 46085-021	8	1	* 56027-126	28	1
46086-017	8	1	* 56027-133	22	1
* 46089-011	8	1	* 56027-134	22	1
46091-010	8	1	* 56027-135	28	1
46092-015	8	1	* 56027-136	28	1
46094-011-21	8	1	92001-104	20	4
46098-010	14	1	92001-121	24	1
46100-002	14	1	* 92001-122	28	2
* 46101-007	14	1	92003-076	10	1
46104-005	14	2	92007-025	10	1
46105-005	14	1	* 92007-032	42	2
46106-007	14	1	* 92011-030	28	4
46106-008	14	1	92015-041	30	2
46124-006	14	1	* 92015-059	32	4
46125-005	14	1	* 92018-003	24	4
46126-001	14	1	92019-007	12	1

## Numerical Parts Index (New Part No. Sequence)

\*: Indicates the Newly developed parts for Kawasaki 350 Model S2- A

New Part No.	Old Part No.	Part Name	Page	Quantity	
* 92019-014	16	1	92072-050	22	1
92022-024	6	1	92073-C01	38	1
92022-125	16	6	* 92073-023	40	1
92022-125	34	3	92075-041	24	1
92022-125	34	3	92075-076	15	2
92022-193	16	4	92075-076	34	3
92022-193	24	2	92075-112	34	3
92022-199	10	2	* 92075-128	34	4
* 92022-240	28	4	* 92075-156	26	5
92025-048	6		92075-158	34	2
92025-049	6		* 92075-168	28	4
92025-050	6		* 92075-169	28	4
92025-051	6		92076-C15	10	2
92025-052	6		92076-C20	10	2
92025-053	6		92077-020	24	1
92025-054	6		* 92088-C16	20	2
92025-055	6		92090-C07	14	1
92025-056	6		92090-020	14	1
92025-057	6				
92025-C58	6				
92026-074	10	2			
92027-120	34	3			
92027-122	16	2			
92027-129	16	2			
92027-129	34	3			
92027-147	34	2			
92037-010	22	6			
92037-010	24	2			
* 92037-096	16	1			
* 92037-097	16	1			
* 92037-099	14	1			
92041-003	26	2			
92043-053	30	2			
92043-079	10	2			
92043-094	22	1			
92047-006	14	2			
* 92050-049	20	1			
92052-005	20	1			
92059-068	22	1			
92059-072	24	1			
92059-073	22	2			
92065-081	22	1			
92065-086	24	1			
* 92068-C07	28	2			
92069-C17	32	1			
92069-018	32	5			
92069-055	34	4			
92069-063	34	1			
* 92069-069	36	1			
* 92069-070	36	1			
* 92069-071	36	1			
* 92069-072	36	1			
* 92071-065	24	1			
92072-030	38	5			
92072-031	38	1			
92072-032	38	1			

## Standard Hardwares Index (Part No. Sequence)

\* : Indicates the Newly developed parts for Kawasaki 350 Model S2-A

Part No.		Part Name	Page	Quantity
110B0610	14	1	411B0500	32 4
110B0614	6	1	411B0600	16 4
110B0614	26	3	411B0600	16 4
110B0614	26	4	411D0600	24 1
110B0618	16	4	411E0600	24 1
110B0622	34	3	411B0600	26 3
110B0622	34	3	411B0600	26 4
110B0812	28	4	411B0800	28 6
110B0816	16	4	410D0600	34 8
110B0816	28	2	461E0500	32 4
110N0625	8	1	461F0400	32 6
110N0625	40	2	461F0500	32 2
113B1032	14	2	461F0600	6 1
113N1025	16	2	461F0600	14 1
114B0812	14	1	461F0600	16 4
116B0610	14		461F0600	16 8
116B0614	6		461F0600	24 1
116B0614	26		461FC600	24 2
116B0614	26		461F0600	24 2
116B0618	16		461F0600	26 3
116B0622	34		461F0600	26 4
116B0622	34		461FG600	34 3
116B0816	38	2	461FG600	34 4
116N0630	34	4	461F0600	42 1
172G0830	14	4	461F0800	12 6
220B0408A	12	2	461F0800	14 1
220B0408A	32	6	461F0800	16 4
220B0508A	32	2	461FG800	28 8
220B0612	42	1	461F0800	38 2
220B0614	24	2	461F1000	10 2
220EG420A	34	8	461F1000	14 2
220E0435A	34	2	461F1000	16 2
220EG612	16	2	461F1000	34 4
220EG614	16	4	461F1000	42 2
220E0620	16	2	461F1200	10 1
220F0635	24	1	463H0800	12 1
220E0655	24	1	481J1800	40 1
222F0408A	20	4	481J4200	20 1
310B0600	16	4	550D1615	14 1
310B0600	16	4	550D2012	10 2
310B0800	14	4	601B6302	20 1
310N0600	34	4	601B6302Z	20 1
311B0600	28	4	67GB2015	24 1
312B0600	24	1	695X5098	18 1
312N0600	40	1	700QC5600	24 1
313B1000	10	2		
313B1000	16	2		
313N0800	40	1		
315B1000	34	4		
315B1200A	10	1		
315N1200A	14	1		
410B0600	14	1		
410B0600	40	2		
410B0800	12	1		
410B1000	10	3		
410B1000	42	2		