

Kawasaki

KV75

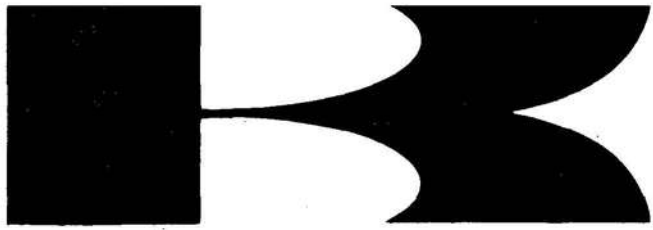

**Motorcycle
Service Manual**



Kawasaki

KV75



Motorcycle Service Manual

TABLE OF CONTENTS

Foreword	1
Model Identification	2
Specifications	3
Engine Adjustments	5
Chassis	9
Disassembly.....	11
Disassembly - Engine Installed.....	13
Disassembly - Engine Removed	29
Disassembly - Chassis.....	37
Maintenance	47
Appendix - Periodic Maintenance.....	77
Appendix - Troubleshooting Guide.....	77
Appendix - Wiring Diagram.....	83

Model Identification

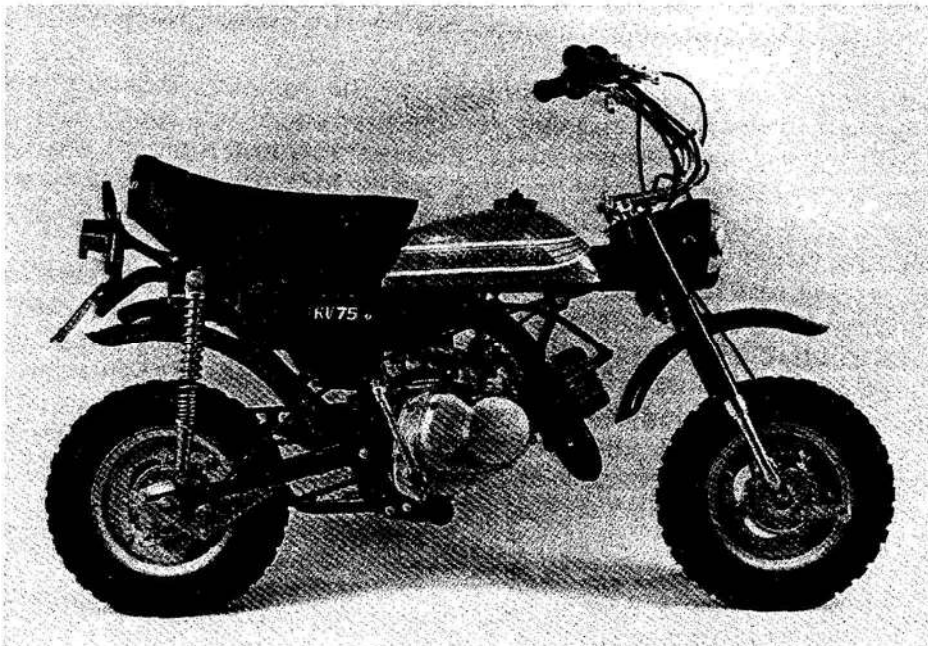
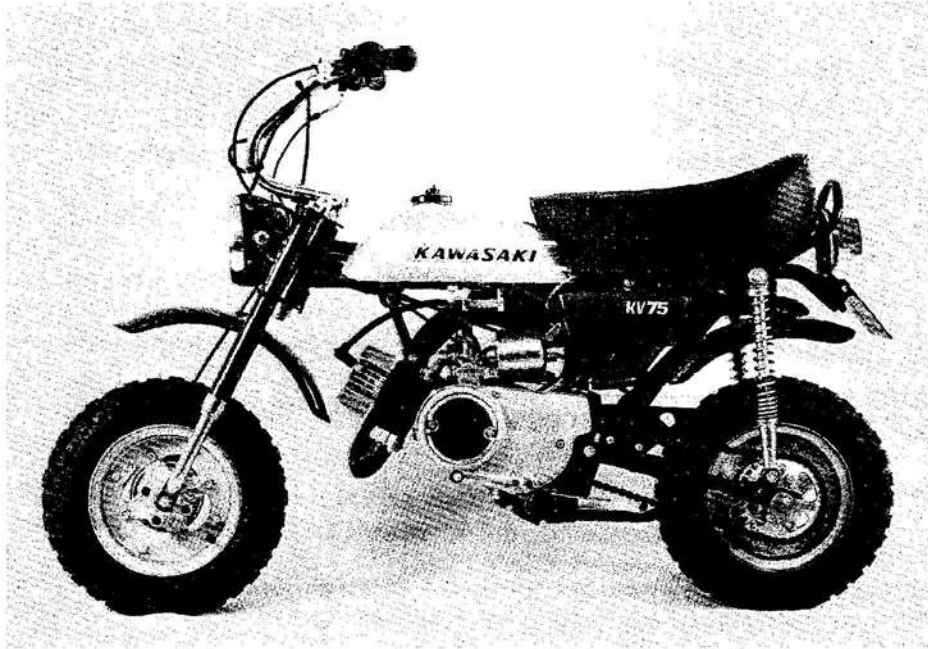

SPECIFICATIONS

Dimensions

Overall length	1350mm (53.1 in.)
Overall width	600mm (23.6 in.)
Overall height	875mm (34.4 in.)
Wheelbase	965mm (38.0 in.)
Road clearance	155mm (6.1 in.)
Fuel tank capacity	3.0 l (0.8 U.S. gal.)
Oil tank capacity	1.0 l (1.1 U.S. qt.)

Performance

Climbing ability	30°
Minimum turning radius	1.5m (59.0 in.)

Engine

Type	2 stroke, single cylinder, piston valve
Bore and stroke	46.0 x 44.0mm (1.81 x 1.73 in.)
Displacement	73cc (4.45 cu. in.)
Compression ratio	6.7:1
Maximum horsepower	4.2 HP at 6,500 rpm
Maximum torque	0.57 kg-m at 5,500 rpm (4.12 lb-ft at 5,500 rpm)

Port Timing

Intake	Open	63° BTDC
	Close	63° ATDC
Scavenging	Open	54°30' BBDC
	Close	54°30' ABDC
Exhaust	Open	73° BBDC
	Close	73° ABDC
Carburetor type		Mikuni VM15SC
Lubrication system		Superlube (oil injection)
Engine oil		2 stroke oil
Starting system		Kick
Ignition system		Magneto
Ignition timing		21° BTDC/1.85mm (0.073 in.) BTDC
Spark plug		NGK B7HS

Transmission

Type	3-speed, constant mesh, return shift	
Clutch	Wet, multi-disc, automatic	
Gear Ratios:	1st	2.91 (32/11)
	2nd	1.53 (26/17)
	3rd	1.05 (22/21)
Primary reduction ratio	3.35 (57/17)	
Final reduction ratio	2.54 (33/13)	
Overall drive ratio	8.92 (3rd)	
Transmission oil capacity	0.6 l (0.63 U.S. qt.)	

4 SPECIFICATIONS

Electrical equipment

Flywheel magneto

Mitsubishi FAZ-1W1L

('74 and earlier)

Mitsubishi F000T03471 ('75 on)

Ignition coil

Mitsubishi F006T40197

Headlight type

Semi sealed beam

Headlight

6V 25/25W

Tail light bulb

6V 3W

Frame

Type

Tubular, backbone

Castor

63°

Trail

60mm (2.4 in.)

Tire size

Front

3.50-8 2PR

Rear

3.50-8 2PR

Suspension

Front

Telescopic fork

Rear

Swing arm

Brakes

Type

Internal expanding, leading-trailing

Inside diameter

Front

105 x 15mm (4.13 x 0.59 in.)

Rear

105 x 15mm (4.13 x 0.59 in.)

Specifications subject to change without notice.

ENGINE ADJUSTMENTS

THROTTLE CONTROL CABLE

The throttle control cable is actually an assembly of three cables: the throttle grip cable, the carburetor cable, and the oil pump cable. The throttle grip cable runs from the throttle grip to the cable assembly junction where it connects to the carburetor cable, which leads to the carburetor, and the oil pump cable, which leads to the oil pump.

Since the throttle grip controls both the carburetor and the oil pump simultaneously, it is important that each cable be adjusted to its designated base position so that the quantity of oil and fuel/air mixture reaches the engine in the correct proportion at all throttle openings. Stretching of the cables creates excess play at the throttle grip and alters the base positions of the cables at the carburetor and the oil pump, necessitating periodic adjustment.

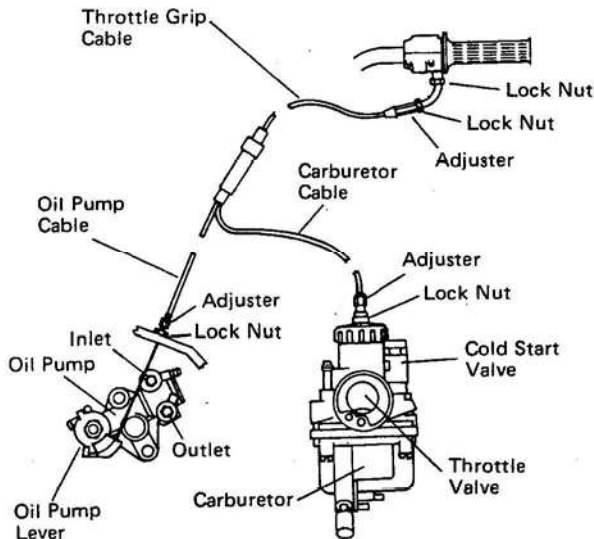

THROTTLE GRIP CABLE

The throttle grip cable, connecting to both the carburetor cable and the oil pump cable, controls both the carburetor throttle valve and the oil pump lever. If there is too much play in the cable, neither the carburetor nor the oil pump will respond immediately when the grip is turned. Most of this excess play must be adjusted out. However, a small amount has to be left so that the steering movement will have no effect on the throttle valve or oil pump lever.

ADJUSTMENT

- Loosen the lock nut at the throttle grip end of the throttle grip cable.
- Turn the adjusting nut until the desired amount of throttle grip play is reached.

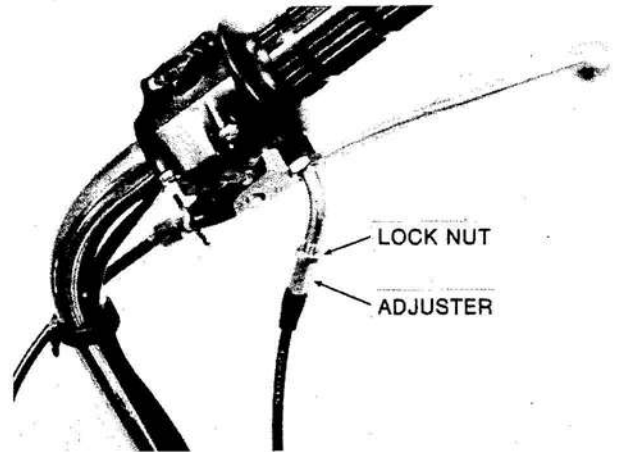

- Tighten the lock nut.

CARBURETOR CABLE

The carburetor cable forms one of the two lower branches of the throttle control cable assembly. It is adjusted so that if the throttle valve were to be closed fully (not at idle but all the way down), all the play in the carburetor cable would be taken up.

The play that develops as the cable stretches will cause a delayed engine response, and should faulty adjustment cause the cable to pull the throttle valve out of its rest position, proper idling cannot be achieved. If the carburetor cable is out of adjustment, the oil and fuel/air mixture ratio will be incorrect, resulting in over or underlubrication. Adjust the carburetor cable whenever the throttle does not respond properly and at least every 3,000 km (2,000 mi.) to compensate for cable stretch.

ADJUSTMENT

- Warm up the engine for about 5 minutes, and then turn off the engine.
- Check to see that the throttle grip has the proper amount of play (Pg 5).
- Turn out the idling screw (throttle stop screw) until the throttle valve reaches its lowest position.

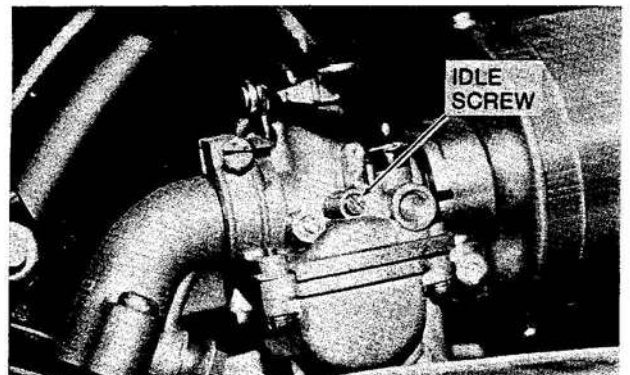

6 ENGINE ADJUSTMENTS

- Loosen the lock nut at the lower end of the carburetor cable, and with the adjuster, eliminate the play between the cable and the throttle valve so that the slightest tug on the outer cable will affect the throttle valve. Be careful not to turn the adjuster so far that the throttle valve rises out of zero position.

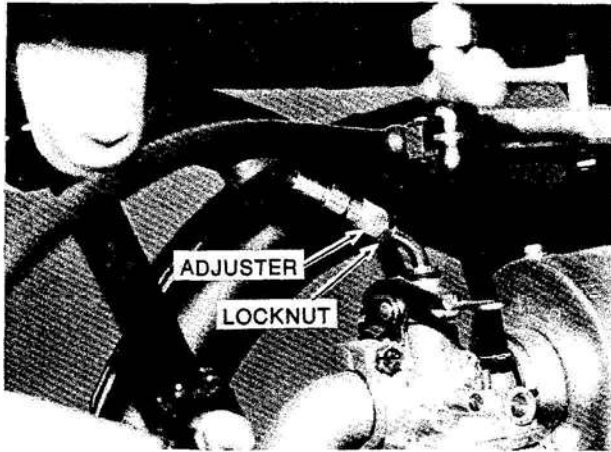

- Tighten the lock nut.
- Adjust the idling speed (Page 6). After the idling speed has been adjusted, a small amount of play will exist between the carburetor cable and the throttle valve. This play should not be altered.

OIL PUMP CABLE

The oil pump cable forms one of the two lower branches of the throttle control cable assembly and connects to the oil pump lever. The cable must be kept adjusted so that the oil pump output which is dependent on throttle movement is minimal at zero throttle and increases at a predetermined throttle opening. This adjustment is correct when the mark on the oil pump lever lines up with the mark on the oil pump lever stopper at zero throttle.

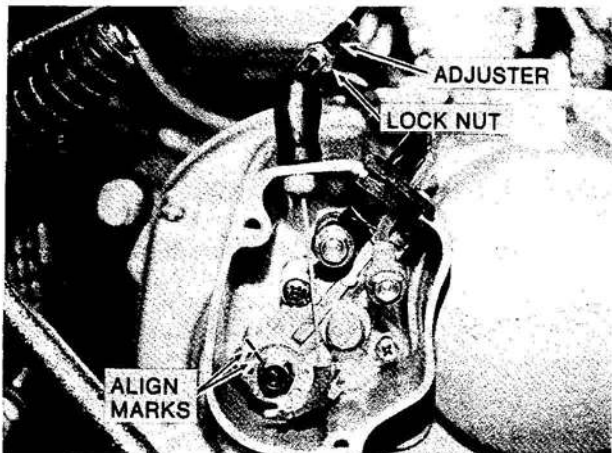

If adjustment is neglected or not carried out properly whenever necessary, the oil supply to the engine will become too low or too high, resulting in piston seizure from under lubrication or poor performance and spark plug trouble from over lubrication. The oil pump cable must be adjusted whenever the oil pump marks are found to be misaligned at zero throttle. At least every 3,000 km (2,000 mi.) and whenever white exhaust smoke is observed or an oil insufficiency is suspected, check the oil pump alignment marks, and then, if necessary, adjust the oil pump cable.

- Check that the throttle grip has the proper amount of play. See (Pg. 5).
- Remove the oil pump cover.
- If the marks are not properly aligned, loosen the oil pump cable lock nut, and turn the adjuster until the marks on the oil pump lever and lever stopper line up. After turning the adjuster, make sure that there is no space between the end of the outer cable and where it should seat in the adjuster.
- Tighten the lock nut.
- Replace the oil pump cover.

CARBURETOR

Although some internal carburetor parts can be adjusted by replacement, repositioning, etc., these adjustments are covered in the Maintenance Section of this manual. The following procedure covers the idling adjustment, which is the adjustment necessary in periodic maintenance and whenever the idling setting has been disturbed.

When the idling speed is too low, the engine may stall, and when the idling speed is too high, the fuel consumption becomes excessive, and a resulting lack of engine brake may make the motor cycle difficult to control. For a proper fuel/air mixture at idling and low speed, it is important when adjusting the idling that the proper setting of the air screw is not neglected.

- Screw in the air screw fully, but not tightly, and then back it out 1 ½ turns. This sets the low speed mixture.

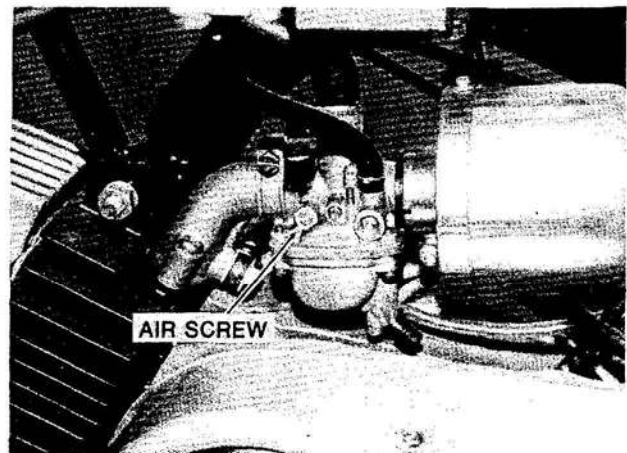

- Warm up the engine for about 5 minutes.
- Screw out the idling screw until the engine is at its lowest possible r.p.m., and then screw it in until the engine reaches its lowest stable r.p.m.

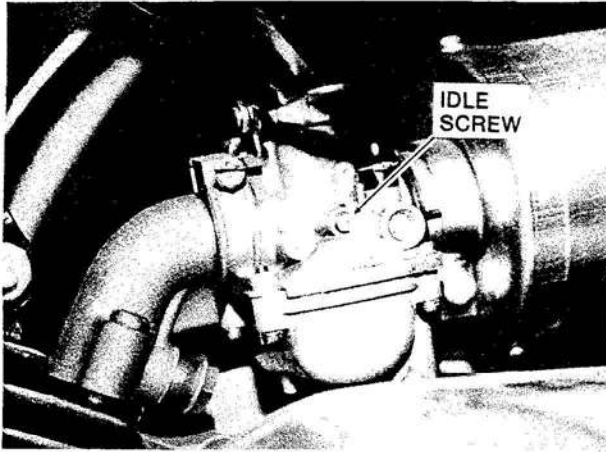

NOTE: The ignition timing must be correct for proper idling adjustment.

SPARK PLUG

Spark plug electrode wear will widen the gap and cause missing and difficulty in starting. Too narrow a gap as a result of maladjustment will also result in poor performance since the small gap will produce only a weak spark.

- Remove the spark plug using a spark plug wrench.
- Clean off the electrodes, and measure the gap with a wire-type thickness gauge. The gap should be 0.7mm (0.028 in.); if it is not, bend the outer electrode with a suitable tool to obtain the correct gap.

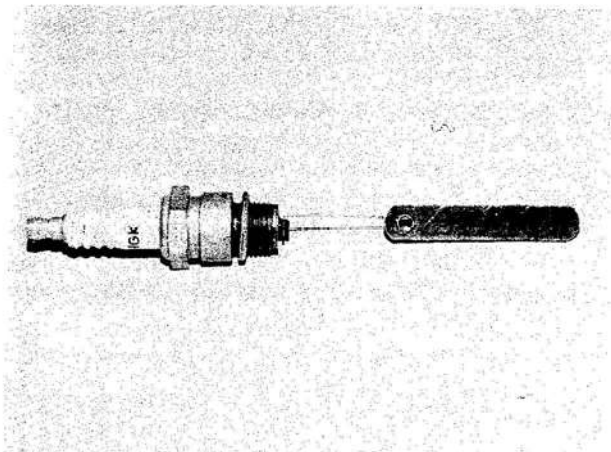

- The spark plug should be tightened to 2.5 - 3.0 kg-m (18.5 - 21.0 ft-lbs) of torque.

IGNITION TIMING

Incorrect ignition timing can cause poor performance, knocking, overheating, and serious engine damage. Periodic adjustment will be necessary to compensate for wear of parts, and the ignition timing must be checked whenever ignition related parts have been disassembled or replaced.

Correct ignition timing is achieved by adjusting through the inspection window of the magneto flywheel the position of the contact breaker base so that the points are just beginning to open when the timing mark on the outer circumference of the flywheel aligns with the timing mark on the crankcase, or when the piston is positioned 1.85mm (0.073 in.) BTDC (before top dead center) by the use of a dial gauge. When the timing marks are aligned, the piston is positioned close to 1.85mm (0.073 in.) BTDC, by which the ignition can be set for good performance. However, best performance is generally achieved by having ignition take place as close as possible to 1.85mm BTDC. When precise ignition timing is desired, a dial gauge is used in place of the timing marks to set the position of the piston. Once the timing has been adjusted, it may be checked for accuracy by the use of a strobe light. there is no adjustment for maximum point gap.

- Mark the position of the shift pedal so that it can later be replaced on the shaft in the same position, and then remove the shift pedal and the left engine cover.
- Disconnect the black magneto lead from where it connects below the fuel tank to the black ignition coil lead.
- Rotate the magneto flywheel counterclockwise until the timing mark on the flywheel lines up with the timing mark on the crankcase.

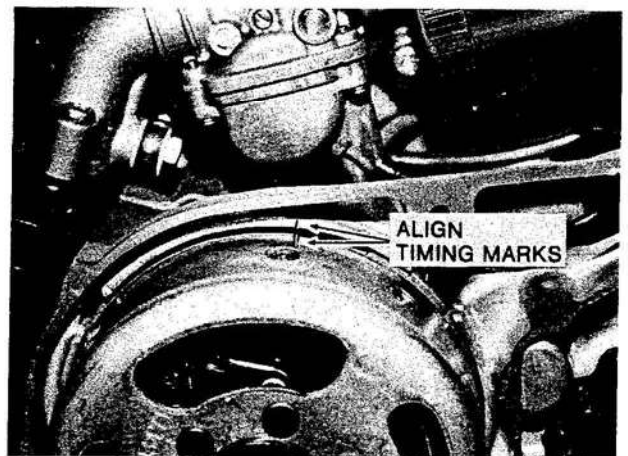

- Connect an ohmmeter (or buzzbox or light) set to the R x 1 range across the contact points by securing one lead to chassis ground (such as the crankcase) and securing

8 ENGINE ADJUSTMENTS

the other lead to the black magneto lead. Be sure that the ohmmeter leads are connected with firm electrical contact.

Ignition Timing Test

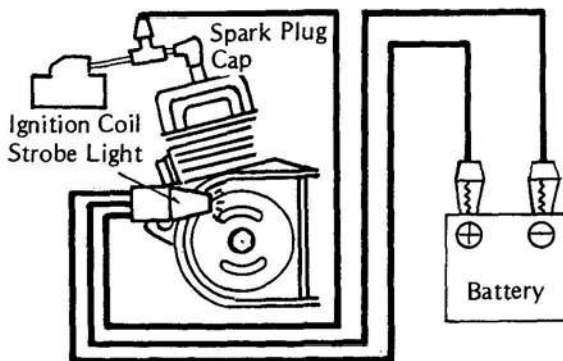

- Loosen the contact breaker base screw just enough to allow the base to move.
 - Use a screwdriver on the pry points to adjust the position of the contact breaker base until the contact breaker points are just at the point of opening. The ohmmeter needle starts to rise when the points just begin to open. Note that total needle travel as the points open is only about 1.5Ω .
 - Once the base seems properly positioned, tighten the base screw, rotate the flywheel a little clockwise, and then slowly rotate it counterclockwise. When the needle starts to rise, the timing marks should be aligned. If they are not, readjust and recheck until the correct contact breaker base position is reached.
 - Disconnect the ohmmeter, and reconnect the leads that were disconnected.
- To check to see whether or not the ignition timing is correctly set, a strobe light may be used.
- Connect the light in the manner prescribed by the manufacturer. One example is shown in the illustration.

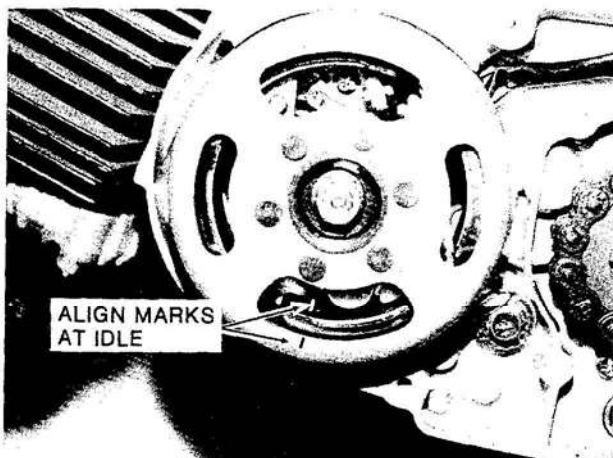

- With the engine idling, direct the light at the timing mark on the crankcase. If the marks are aligned when the light flashes, the ignition timing is correctly set.

NOTE: For even better accuracy, a dial gauge can be used to set the position of the piston. Instead of aligning the timing marks, the following steps can be substituted:

- Remove the cylinder head. See Pg. 18.
- Rotate the magneto flywheel counterclockwise until the position of the piston is close to the top.
- Using a suitable adapter, mount a dial gauge on the cylinder, rotate the flywheel to set the piston at exact TDC, and set the dial to zero.

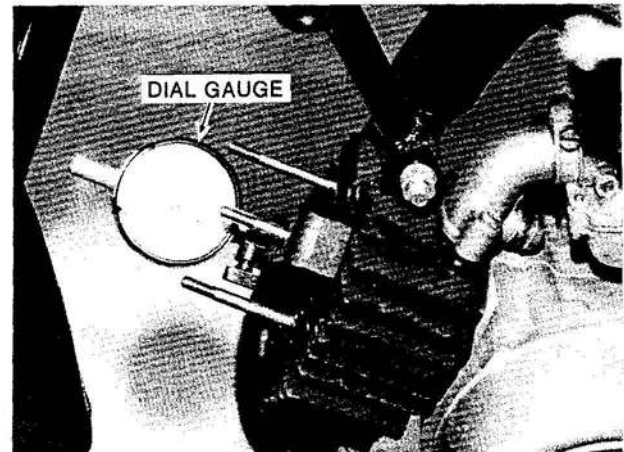

- Rotate the flywheel clockwise until the dial gauge reads about 2.5mm (0.10 in.) and then counterclockwise until the dial gauge reads 1.85mm (0.073 in.). At this point the piston is properly positioned such that, while using an ohmmeter or another timing device, the contact breaker base can be adjusted to set the timing. When replacing the cylinder head, be sure that the nuts are tightened in a cross-pattern to 0.6 – 0.9 kg-m (4.5 – 6.5 ft-lbs) of torque.

NOTE: When setting the ignition timing by the use of a dial gauge to determine piston position, the flywheel timing marks cannot be relied upon to check the timing. The dial gauge reading is referred to throughout the entire adjustment instead of the timing marks. Before checking with a strobe light, first make a new timing mark on the flywheel by marking the flywheel just under the mark on the crankcase once the piston has been set at 1.85mm (0.073 in.) BTDC.

CHASSIS ADJUSTMENTS

STEERING

For safety, the steering should always be kept adjusted so that the handlebar will turn freely but not have excessive play.

If the steering is too tight, it will be difficult to turn the handlebar quickly, the motorcycle may pull to one side, and the steering stem bearings may become damaged. If the steering is too loose, the handlebar will vibrate, and the motorcycle will be unstable and difficult to steer in a straight line.

To check the steering adjustment, first support the motor cycle so that the front wheel is raised off the ground. Push the handlebar lightly to either side; if it continues moving under its own momentum, the steering is not too tight. Squatting in front of the motorcycle, grasp the lower ends of the front fork outer tubes, and shake it back and forth; if no play is felt, the steering is not too loose.

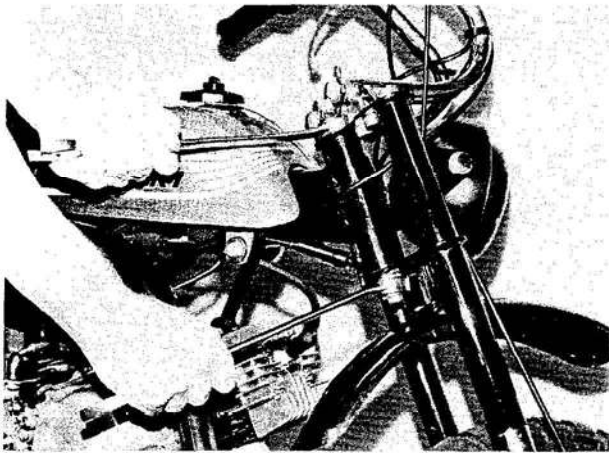

- Tighten or loosen the nut on the steering stem bolt to achieve the proper adjustment as described.

BRAKES

Brake lining and drum wear causes the brakes to go out of adjustment, increasing lever play and decreasing braking effectiveness. Brake adjustment to compensate for this consists of adjusting the brake lever travel.

Once the brakes have been adjusted, spin or turn the wheels to check for drag. If any drag is heard or felt, disassemble the brake, and inspect for wear or damage. Also, if the brake levers do not return to rest position quickly upon release, check the brake for wear.

BRAKE LEVERS

- Loosen the lock nut at each brake lever, screw the adjuster fully in, and tighten the lock nut.

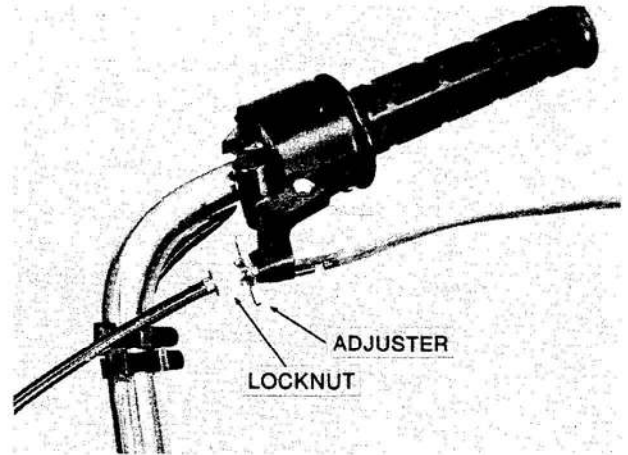

- Adjust the adjusting nut on the lower end of the brake cable so that when the brake is fully applied, there is 55 - 65mm (2 - 2 1/2 in.) of space left between the throttle grip and the end of the brake lever.

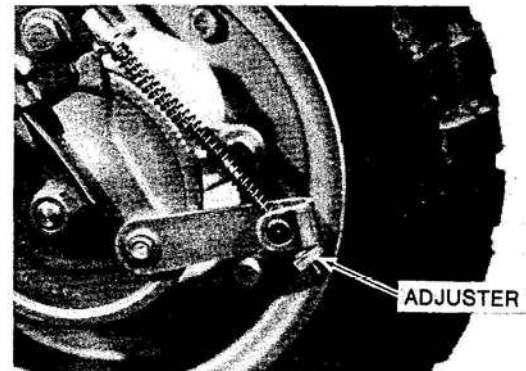

- Check for brake drag.
- For additional adjustment or minor corrections while riding, use the adjuster at the front brake lever.

10 CHASSIS ADJUSTMENTS

DRIVE CHAIN

Chain and sprocket wear causes the chain to become loose and results in power loss, increased wear, and noise. A loose chain may break or slip off the sprockets during operation. A chain that is too tight will also wear quickly and possibly break.

With the motorcycle off its side stand and vertical to the ground, the chain should have a maximum of about 15 - 20mm (5/8 - 3/4 in.) of vertical movement at its greatest point. If the slack exceeds this amount, adjust the chain.

Chain Slack

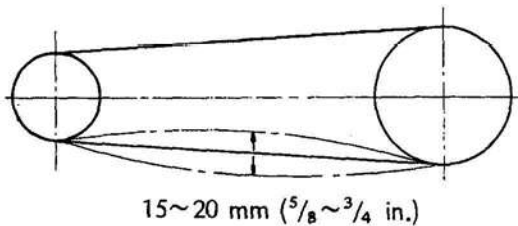

CAUTION A chain worn past the service limit should be replaced. Such wear cannot be adequately compensated by adjustment.

- Loosen the torque link nut.
- Loosen the rear axle nut.
- If the chain is too tight, turn the scroll adjusters and then kick the wheel forward until the chain becomes overly loose.

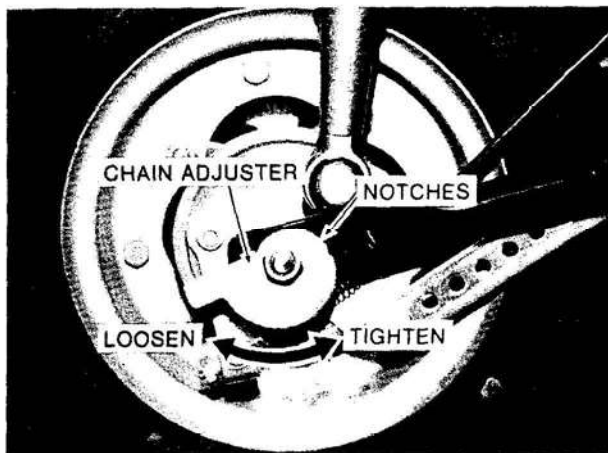

- Turn the right and left scroll chain adjusters evenly until the chain has the correct amount of slack. To keep the chain and wheel aligned, each adjuster must be turned to the same notch.
- Tighten the axle nut to 4.5 - 6.2 kg-m (33 - 45 ft-lbs) of torque. Then turn the wheel and check the adjustment, redoing it if necessary.

- Tighten the torque link nut to 3.0 - 3.5 kg-m (22 - 25 ft-lbs) of torque.
- Check the rear brake (Pg. 9) adjustment.

HEADLIGHT

The headlight beam is adjustable only vertically.

To adjust the vertical direction of the beam, loosen the headlight assembly mounting bolts on both sides, set the headlight assembly in the desired position, and retighten the mounting bolts.

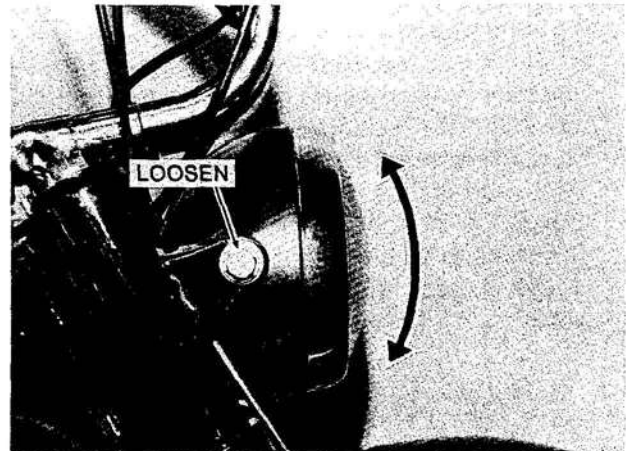

DISSASSEMBLY

INTRODUCTION TO DISSASSEMBLY

Detail has not been spared in this section in order that the motorcycle can not only be taken apart but also put back together properly. Photographs, diagrams, notes, cautions, warnings, and detailed descriptions have been included wherever necessary. Nevertheless, even a detailed account has limitations; a certain amount of basic knowledge is also required for successful work. Especially note the following:

(1) Edges

Watch for sharp edges, especially during major engine disassembly and assembly. Protect your hands with gloves or a piece of thick cloth when lifting the engine or turning it over.

(2) Dirt

Before removal and disassembly, clean the motorcycle. Any dirt entering the engine, carburetor or other parts will work as an abrasive and shorten the life of the motorcycle. For the same reason, before installing a new part, clean off any dust or metal filings.

(3) Tightening Sequence

Where there is a tightening sequence indication in this Service Manual; the bolts, nuts, or screws must be tightened in the order and method indicated. When installing a part with several bolts, nuts, or screws; they should all be started in their holes and tightened to a snug fit. Then tighten them evenly, according to the tightening sequence, to the specified torque. This is to avoid distortion of the part and/or causing gas or oil leakage. Conversely, when loosening the bolts, nuts, or screws; loosen all of them about a quarter of turn and then remove them.

(4) Torque

The torque values given in this Service Manual should always be used. Either too little or too much torque may lead to serious damage. Use a good quality, reliable torque wrench.

(5) Force

Common sense should dictate how much force is necessary in assembly and disassembly. If a part seems especially difficult to remove or install, stop and examine what may be causing the problem. Whenever tapping is necessary, tap lightly using a wooden or plastic-faced mallet. Use an impact driver for screws (particularly for the removal of screws held by a locking agent) in order to avoid damaging the screw heads.

(6) Lubricant

Don't use just any oil or grease. Some oils and greases in particular should be used only in certain applications and may be harmful if used in an application for which they are not intended.

(7) Lubrication

Engine wear is generally at its maximum while the engine is warming up and before all the rubbing surfaces have an adequate lubricative film. During assembly, oil or grease (whichever is more suitable) should be applied to any rubbing surface which has lost its lubricative film. Oil grease and dirty oil should be cleaned off. Deteriorated grease has lost its lubricative quality and may contain abrasive foreign particles.

(8) Press

A part installed using a press or driver, such as a wheel bearing, should first be coated with oil on its outer or inner circumference so that it will go into place smoothly.

(9) Oil Seal, Grease Seal

An oil seal guide is required for certain oil seals during installation to avoid damage to the oil seal lips. Before a shaft passes through an oil seal, apply a little oil, preferably high temperature grease on the lips to reduce rubber to metal friction.

(10) Gasket, O-Ring

When in doubt as to the condition of a gasket or O-ring, replace it with a new one. The mating surfaces around the gasket should be free of foreign matter and perfectly smooth to avoid oil or compression leaks.

(11) Liquid Gasket, Non-permanent Locking Agent

Before using liquid gasket or a non-permanent locking agent, wash or wipe the surfaces where the liquid gasket or non-permanent locking agent are to be applied. Do not use too much, because excessive amounts could block the engine oil passages and cause serious engine damage.

(12) Ball Bearing, Oil Seal, Grease Seal Installation

When installing a ball bearing, the bearing race which is affected by friction should be pushed by a suitable driver. This prevents severe stress on the balls and races, and prevents the races and balls from being dented. Press a ball bearing until it stops at the stop in the hole or on the shaft. Seals should be pressed into place using a suitable driver, which evenly contacts the side

12 INTRODUCTION TO DISSASSEMBLY

of the seal until the face of the seal is even with the end of the hole.

(13) Circlip, Retaining Ring

Replace any circlips and retaining rings that were removed with new ones, as removal weakens and deforms them. When installing circlips and retaining rings, take care to compress or expand them only enough to install them and no more.

TORQUE

Tighten all bolts and nuts to the proper torque using an accurate torque wrench. If insufficiently tightened, a bolt or nut may become damaged or fall off, possibly resulting in damage to the motorcycle and injury to the rider. A bolt or nut which is overtightened may become damaged, strip an internal thread, or break and then fall out. The following table lists the tightening torque for the major bolts and nuts.

When checking the tightening torque of the bolts and nuts, first loosen the bolt or nut by half a turn and tighten to the specified torque.

ENGINE PART	METRIC (kg-m)	ENGLISH (lb-ft)
Exhaust Stud Nuts	0.35 - 0.50	(2.5 - 3.5)
Cylinder Head Nuts	0.6 - 0.9	(4.5 - 6.5)
Engine Sprocket Nut	4.5 - 6.2	(33 - 45)
Flywheel Nut	2.6 - 3.5	(19.0 - 25.0)
Clutch Hub Nut	4.5 - 6.2	(33 - 45)
Input Shaft Gear Nut	5.4 - 7.5	(39 - 54)
Engine Mount Bolts	2.6 - 3.5	(19 - 25)
Cylinder Stay Bolts	1.4 - 1.9	(10.0 - 13.5)
CHASSIS PART		
Axle Nuts	4.5 - 6.2	(32.5 - 44.8)
Brake Drum Bolts	3.0	(22)
Brake Torque Link Bolts	3.0 - 3.5	(21.6 - 25.3)
Rear Sprocket Bolts	3.0	(22)
Hub to Rim Bolts	2.55 - 3.50	(18.4 - 25.3)
Rim Bolts (8mm)	1.35 - 1.85	(9.8 - 13.4)
Rim Bolts (10mm)	2.55 - 3.50	(18.4 - 25.3)
Sg Arm Pivot Nut	2.55 - 3.50	(18.4 - 25.3)
Shock Absorber Bolts	4.5 - 6.2	(32.5 - 44.8)

The table below, relating tightening torque to thread diameter and pitch, lists the basic torque for the bolts and nuts used on Kawasaki Motorcycles. However, the actual torque that is necessary may vary among bolts and nuts with the same thread diameter and pitch. All of these values are for use with dry solvent-cleaned threads.

Coarse threads

dia (mm)	Pitch (mm)	kg-m	lb-ft
5	0.90	0.35-0.50	2.5-3.5
6	1.00	0.6-0.9	4.5-6.5
8	1.25	1.6-2.2	11.5-16.0
10	1.50	3.1-4.2	22-30
12	1.75	5.4-7.5	39-54
14	2.00	8.3-11.5	60-83
16	2.00	13-18	94-130
18	2.50	18-25	130-181
20	2.50	26-35	188-253

Fine threads

dia (mm)	Pitch (mm)	kg-m	lb-ft
5	0.50	0.35-0.50	2.5-3.5
6	0.75	0.6-0.8	4.5-5.5
8	1.00	1.4-1.9	10.0-13.5
10	1.25	2.6-3.5	19.0-25
12	1.50	4.5-6.2	33-45
14	1.50	7.4-10.2	54-74
16	1.50	11.5-16	83-116
18	1.50	17-23	123-166
20	1.50	23-33	166-239

DISASSEMBLY-ENGINE INSTALLED

TABLE OF CONTENTS

Flow Chart	14
Fuel Tank	15
Fuel Tap	15
Air Cleaner Element	15
Carburetor	16
Muffler	18
Ignition Coil	18
TOP END	
Cylinder Head	18
Cylinder	18
Piston, Piston Rings	19
LEFT SIDE	
Engine Sprocket Cover and Sprocket	20
Magneto Flywheel	21
Magneto Stator	21
RIGHT SIDE	
Oil Pump	22
Clutch	24
Shift Mechanism	26
Kickstarter	26

FLOW CHART ENGINE DISASSEMBLY

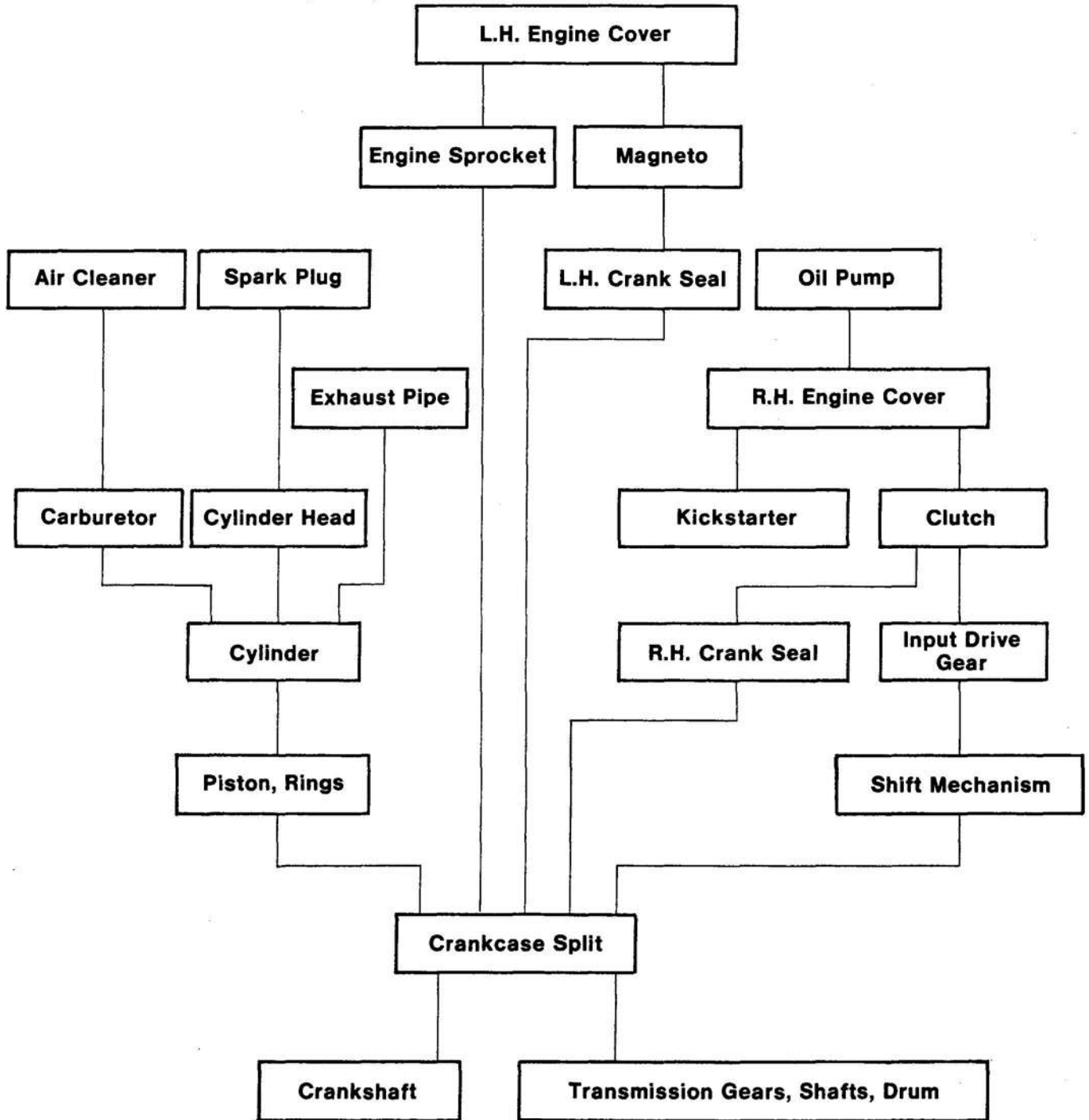

Fuel Tank

Removal:

- Turn the fuel tap to the "OFF" position and then slide the fuel hose off the tap.
- Loosen the top shock absorber nuts, and then lift the rear of the seat straight up. Pull the seat off toward the rear. On 1976 and later models, the seat is removed by pulling up the two seat latches (located one on each side of the rear of the seat), and then pulling the seat off to the rear.

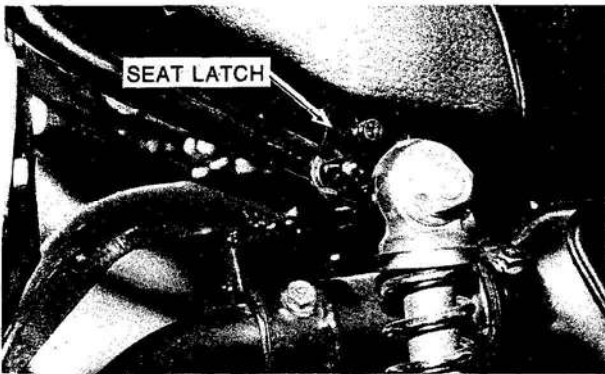
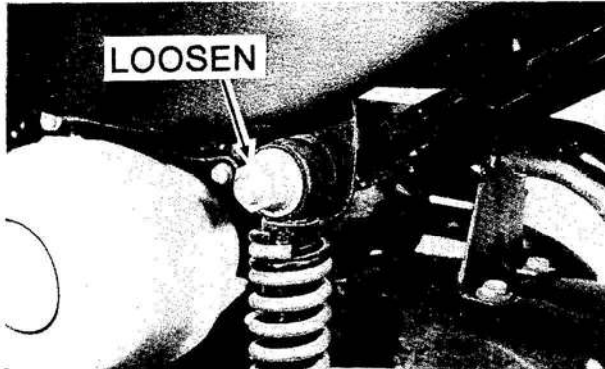

- Remove the fuel tank bolts, and then lift the tank straight up and off the frame.

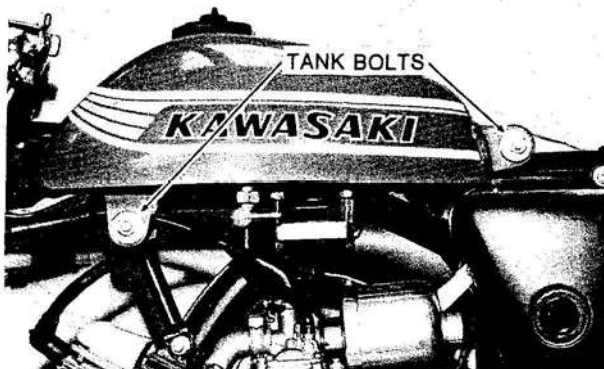

Installation Notes:

- Be careful not to pinch the wiring between the tank and the frame.

Fuel Tap

Removal:

- Remove the fuel tank (p. 15).
- Drain the fuel into a suitable container.
- Loosen the large ring nut holding the tap to the tank.

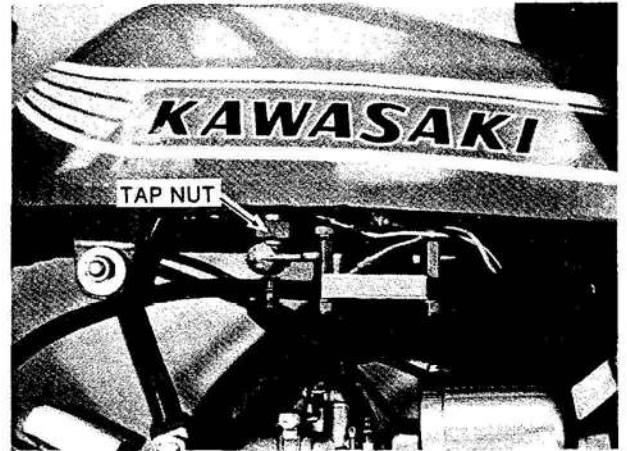

- Pull the tap straight out of the tank. Be careful not to damage the fuel strainer screens on the end of the inlet tube.

Installation Notes:

- Installation is the reverse of removal.

Air Cleaner

Removal:

1971 through 1975 models

- Loosen the clamp screw that holds the air cleaner to the carburetor.

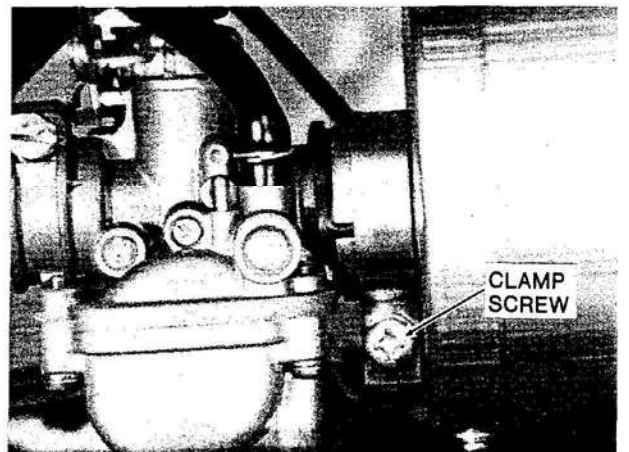

- Pull the air cleaner straight back off the carburetor, and then remove the two screws on the sides of the air cleaner. Separate the air cleaner shell and remove the element.

1976 and newer models

- Remove the seat (see Fuel Tank Removal).

16 DISASSEMBLY - ENGINE INSTALLED

- Temporarily remove the oil tank by taking out the screw that holds it to the frame. Be sure the cap vent is turned to the "OFF" position. Lift the tank to pull the tab on the bottom of the tank out of the socket in the frame. Rest the tank on the foot peg.

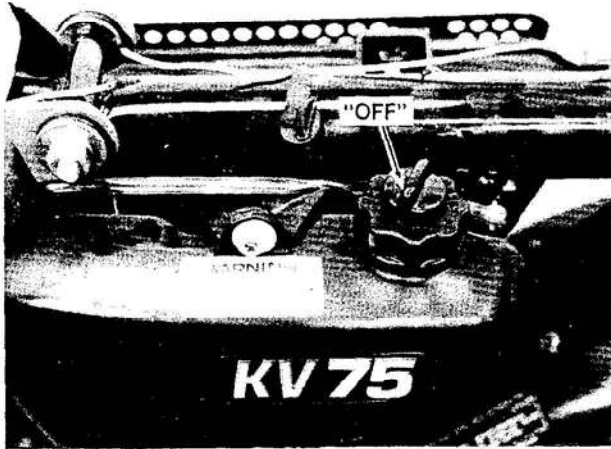

- Remove the screw on the air cleaner brace, and then follow the instructions above for 1971 through 1975 models.

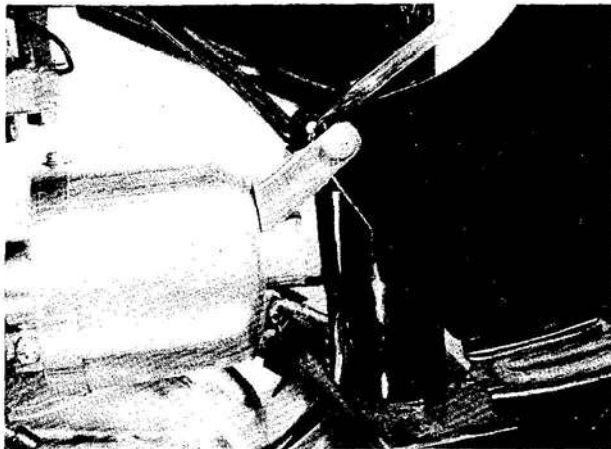

Installation Notes:

- If the foam material of the air filter element is torn or otherwise damaged, it must be replaced.

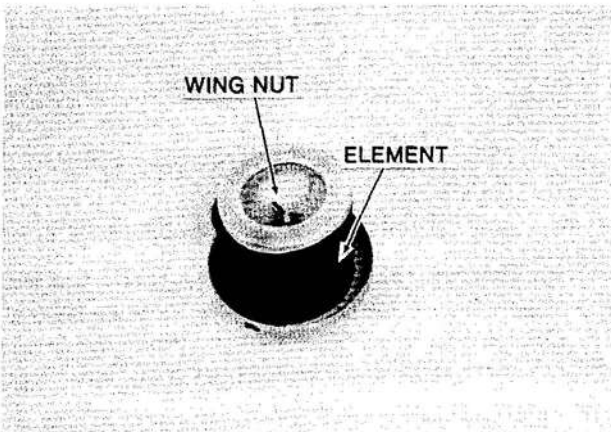

Carburetor

Removal:

- Remove the air cleaner (p. 15).
- Turn the fuel tap to the "OFF" position, and then slip the fuel hose off the carburetor.
- Loosen the carburetor clamp screw, and then pull the carburetor off the holder.

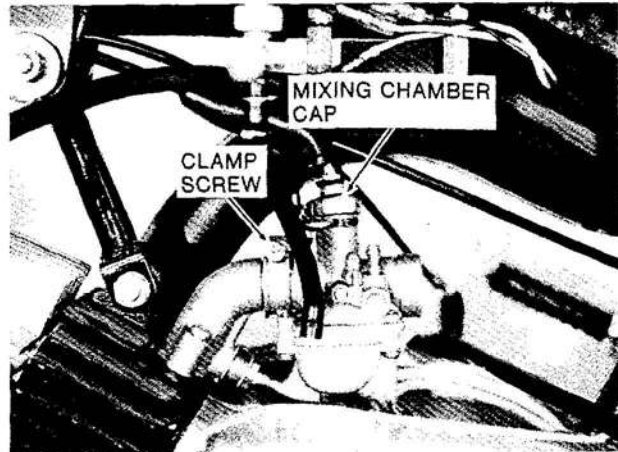

- Unscrew the mixing chamber cap, and pull the slide out of the carburetor. The slide can be removed from the cable by pushing the needle into the slide to dislodge the keeper and then moving the cable to the other side of the keyhole slot.



- Remove the four screws, and take off the fuel bowl.
- Pull out the pivot rod to remove the float. The needle valve will fall out of the inlet needle valve body. The main jet and pilot jet can be removed with a screwdriver. The main jet screws into the needle jet, which is removed by pushing it out the top of the carburetor.

Installation Notes:

- Be sure all parts are clean, and that the needle valve and the jet needle show no wear. Check the specifications (main jet number, jet needle clip position, etc.) against the table in the maintenance section of this manual (p. 77).

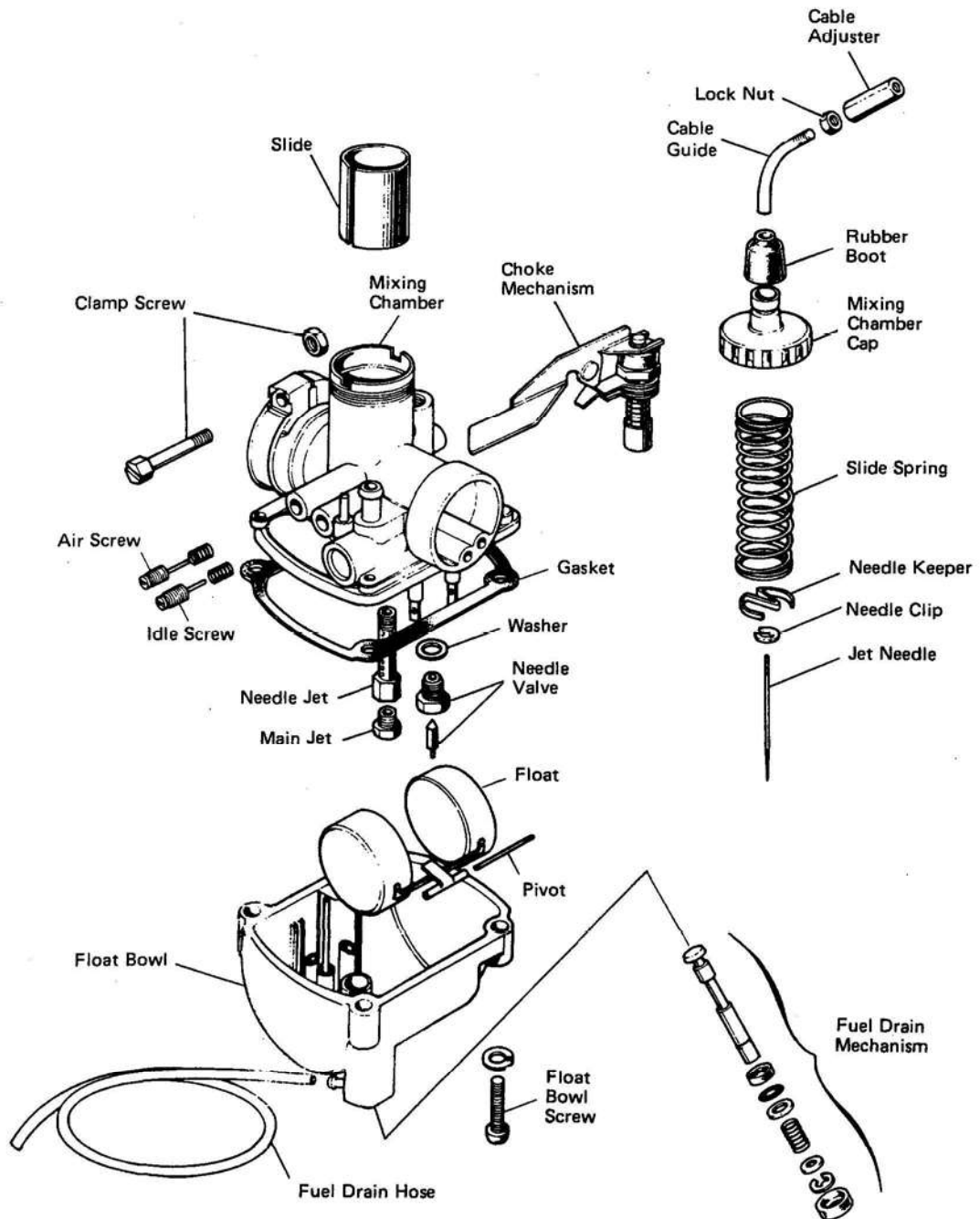
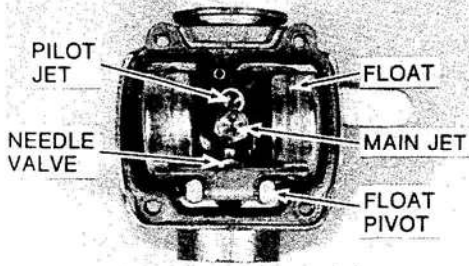

Muffler

Removal:

- Remove the exhaust stud nuts, each with one flat washer and one lockwasher. Remove the bolt holding the muffler to the frame under the edge of seat.

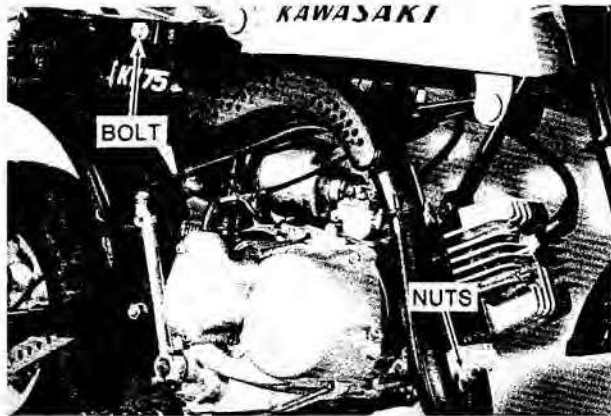

- Pull the muffler forward and off.
- Take out the bolts holding the spark arrestor and baffle tube in the rear of the muffler.

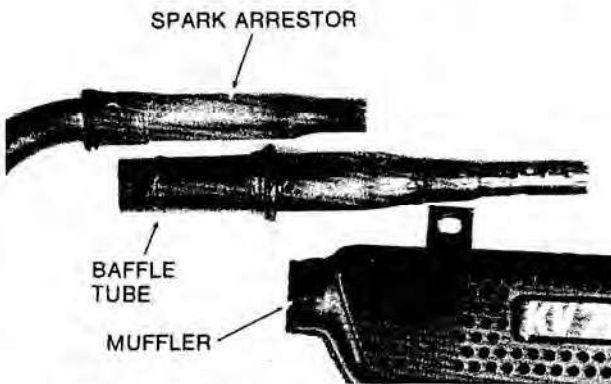

Installation Notes:

- Clean the spark arrestor and the baffle tube of as much carbon and debris as possible. Be sure all the holes in the baffle tube are clean.
- Use a new exhaust gasket at the cylinder to prevent leaks.
- Tighten the exhaust stud nuts to 0.35 to 0.50 kg-m (2.5 to 3.5 lb-ft) of torque.

Ignition Coil

Removal:

- Remove the fuel tank (p. 15).
- Take the spark plug cap off the spark plug by giving it a twist and then pulling.
- Unscrew the bolts with nuts and lockwashers holding the coil to the frame bracket. Pull apart the connector located on the black wire which runs to the coil.

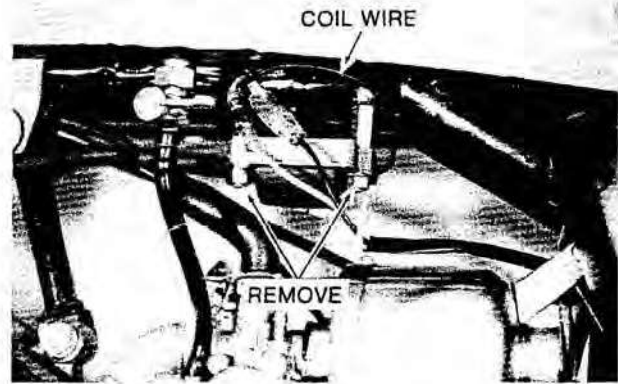

Installation Notes:

- Be sure the coil is well grounded to the frame through its mounting bolts. There is no separate ground wire.

TOP END

Cylinder Head

Removal:

- Pull off the spark plug cap with a twisting motion. Remove the spark plug.
- Take off the four cylinder head nuts, washers, and lockwashers. Slide the head off the studs. Remove the head gasket.

Installation Notes:

- Use a new gasket to assure a good seal.
- Clean out the carbon in the combustion chamber. Be careful not to scratch the aluminum cylinder head. Check the head for warp (p. 54).
- Tighten the cylinder head nuts in a criss-cross pattern to 0.6 - 0.9 kg-m (4.5 - 6.5 lb-ft) of torque.

Cylinder

Removal:

- Remove the muffler (p. 18).
- Remove the carburetor (p. 16).
- Remove the carburetor holder. If the oil pressure line is not to be replaced, do not loosen the banjo fitting on the carburetor holder.
- Remove the cylinder head (p. 18).
- Move the cylinder stay aside by removing the bolt in the cylinder lug and loosening the one below the tank.

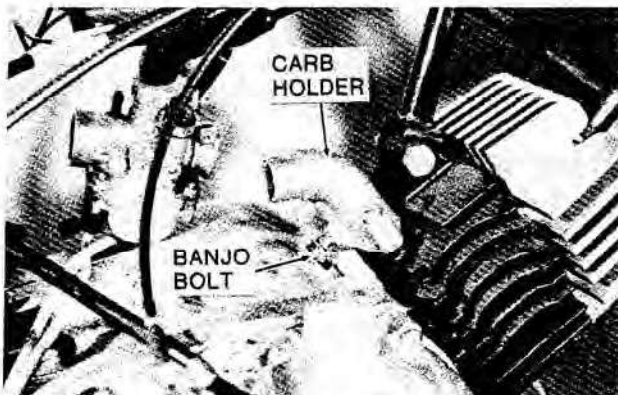

IWASAKI

- Slide the cylinder off. Be careful that the piston does not fall against the cylinder studs when it comes loose.

Installation Notes:

- Use a new cylinder base gasket.
- Put a little oil on the piston rings before assembly.
- Set the piston at bottom dead center, and fit the base of the cylinder over the rings, pressing in on opposite sides as necessary. Be certain the rings do not slip out of the proper position.

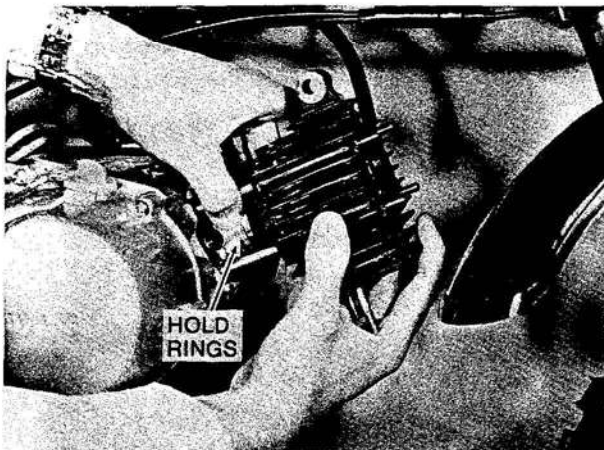

- Tighten the cylinder head nuts in a criss-cross pattern to 0.6 - 0.9 kg-m (4.5 - 6.5 lb-ft) of torque.

Piston, Piston Rings**Removal:**

- Remove the cylinder head (p. 18).
- Remove the cylinder (p. 18).
- Pull the piston up to top dead center.
- Stuff a clean rag around the connecting rod to prevent anything from falling into the crankcase.
- Carefully remove one piston pin circlip and slide the piston pin out.

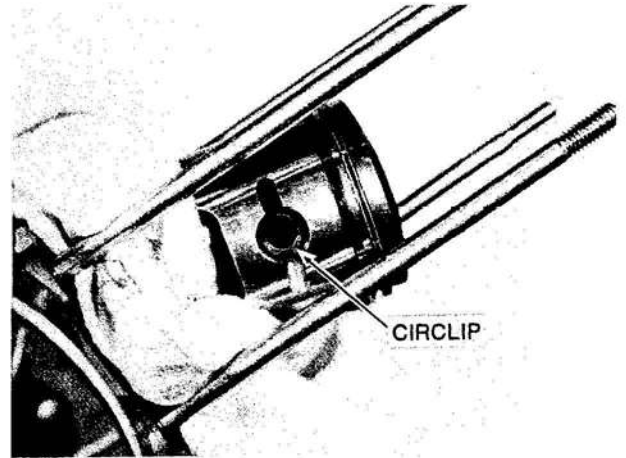

- Lift the piston off the rod, and slip the small end bearing out of the rod eye.
- Remove the piston rings by spreading gently between your thumbs and then lifting them off the piston.

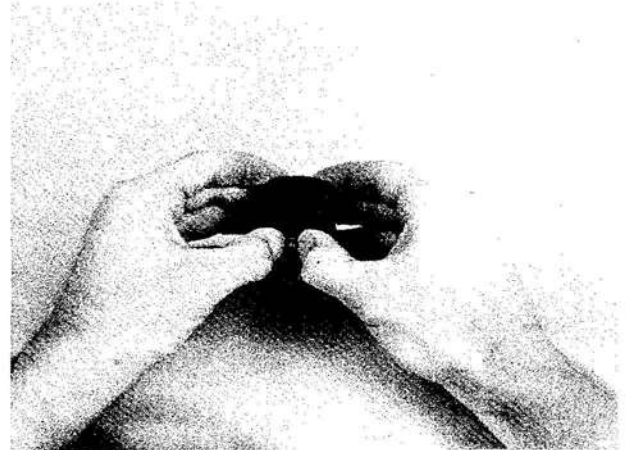
**Installation Notes:**

- Clean the piston head and the ring grooves (p. 51).
- If the piston is to be replaced with a new one, piston to cylinder clearance changes (to measure clearance, see p. 51).
Also, when a new piston pin is used, check that the piston to pin clearance is 0.002 to 0.014mm (0.00008 to 0.00055 in.).

To the dealer: When possible, match parts from stock so that a marked pin is assembled with an "A" piston and an unmarked pin with a "B" piston.

- Install the piston rings so that the marked side faces upward.
- When replacing the piston rings by hand, first fit one end of the piston ring against the pin in the ring groove, spread the ring opening with the other thumb, and then slip the ring into the groove.

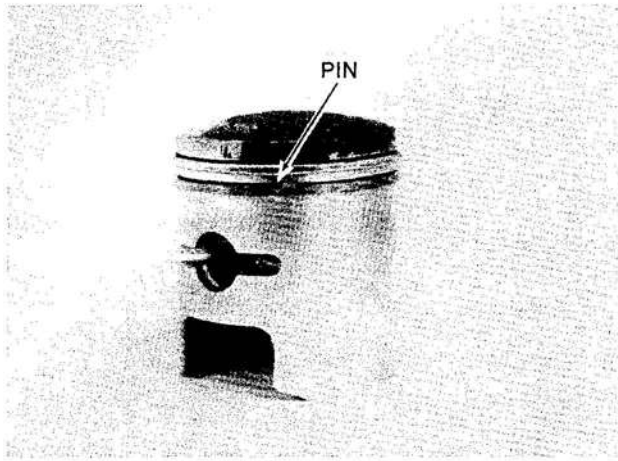

- The arrow on the piston top must point toward the front.

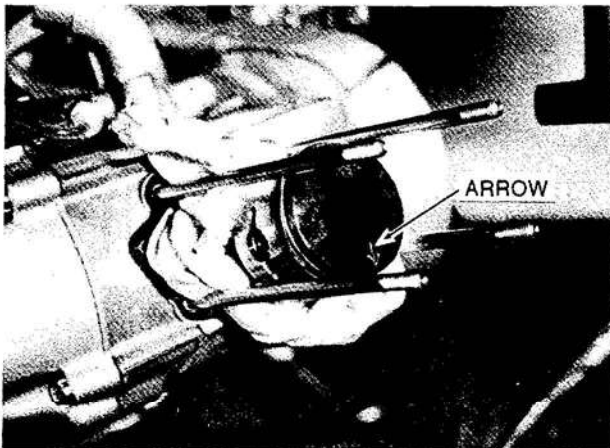

- Oil the piston pin and small end bearing before assembly.
- Use a new piston pin circlip in place of every one removed, as removal weakens and deforms the circlip. After installation, turn the circlip so that its opening is either up or down; it must not coincide with either groove in the side of the piston.

LEFT SIDE

Left Hand Engine Cover and Sprocket Removal:

- Remove the footpeg bar by taking out the four bolts with nuts and lockwashers holding it to the frame.

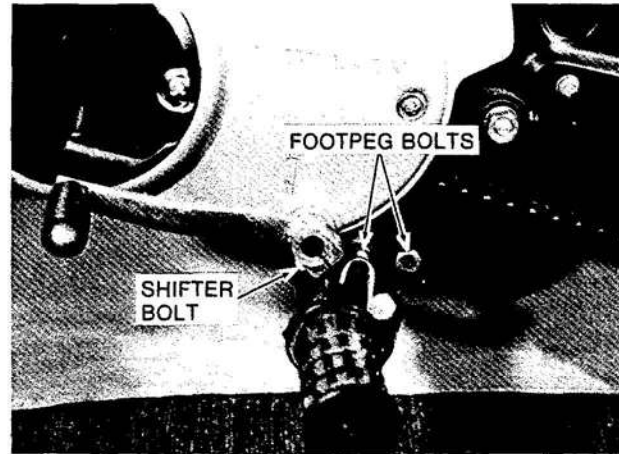

- Remove the shift pedal clamp bolt and slip the shift pedal off the shaft.
- Take out the three screws holding the left hand engine cover to the crankcase. Remove the cover.
- Flatten the lockwasher tab, and then use a sprocket holder (P/N T57001-165) and a socket wrench to remove the sprocket nut (the rear brake can also be used to prevent the sprocket from turning.)

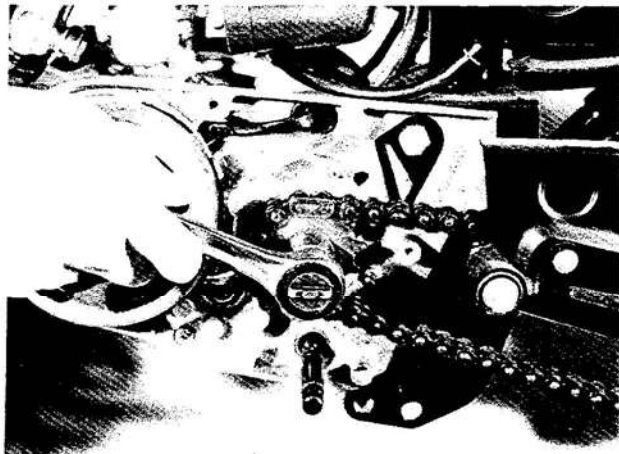

- If necessary, loosen the rear axle nut, turn the adjusters and kick the rear wheel forward to loosen the chain.

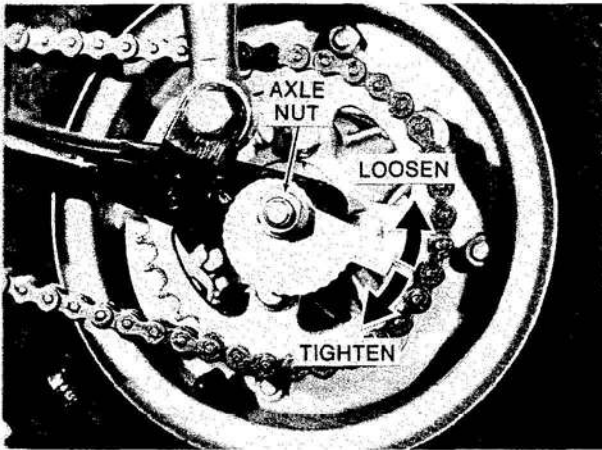

- Lift chain off the sprocket and slip the sprocket off the output shaft.

Installation Notes:

- Tighten the engine sprocket nut to 4.5 - 6.2 kg-m (33 - 45 lb-ft) of torque. Be sure to bend up the side of the lockwasher onto one flat of the nut.

Magneto Flywheel

Removal:

- Remove the left hand engine cover (p. 20).
- Hold the flywheel with the special tool (P/N 57001-155) or a strap wrench. Take off the flywheel nut with a socket wrench. Take off the flywheel nut with a socket wrench.

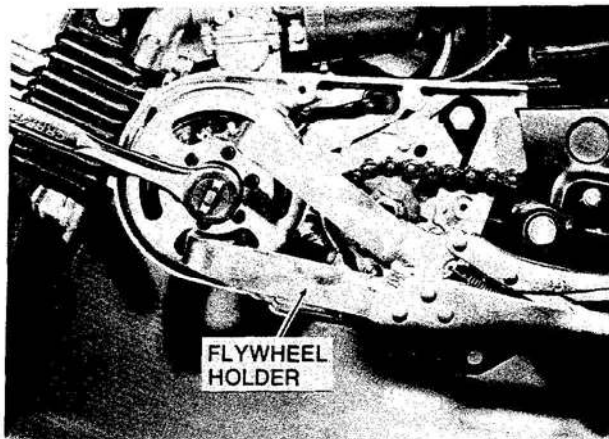

- Use the special tool flywheel puller (P/N 57001-252) to remove the flywheel.

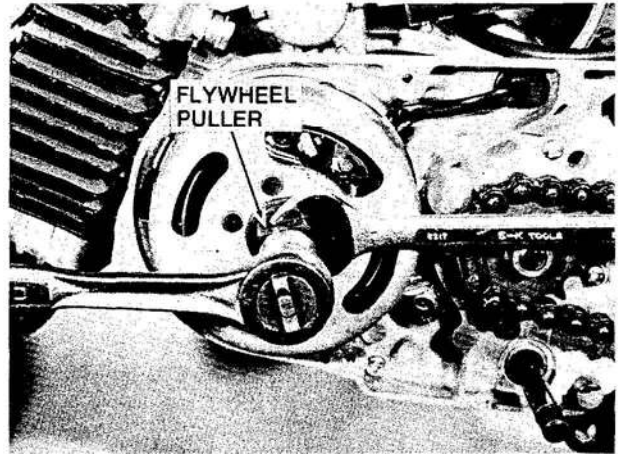

Installation Notes:

- Be sure the inside of the flywheel and the tapers of both the flywheel and the crankshaft are clean and free of foreign objects.
- If the key shows signs of wear, replace it with a new one.
- Tighten the flywheel nut to 2.6 - 3.5 kg-m (19.0 - 25.0 lb-ft) of torque.

Magneto Stator

Removal:

- Remove the left engine cover (p. 20)
- Remove the magneto flywheel (p. 20).
- Pull apart the connectors on the yellow and black wires from the magneto to the main wiring harness.

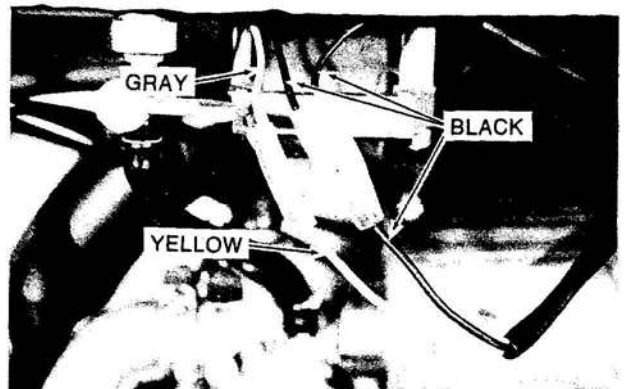

- Take out the three screws holding the magneto stator to the crankcase, and then remove the stator. The grommet will pull out of the notch in the crankcase.

22 DISASSEMBLY - ENGINE INSTALLED

Installation Notes:

- On models with a cast aluminum flywheel, install the stator so that the points are to the rear of the shaft.

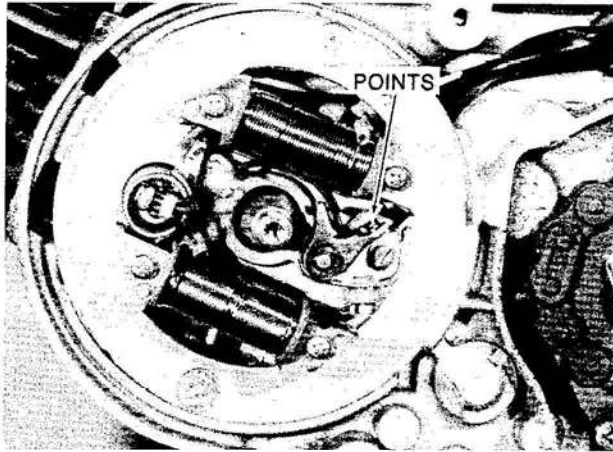

- On models with a stamped steel flywheel, install the stator so that the points are above the shaft.

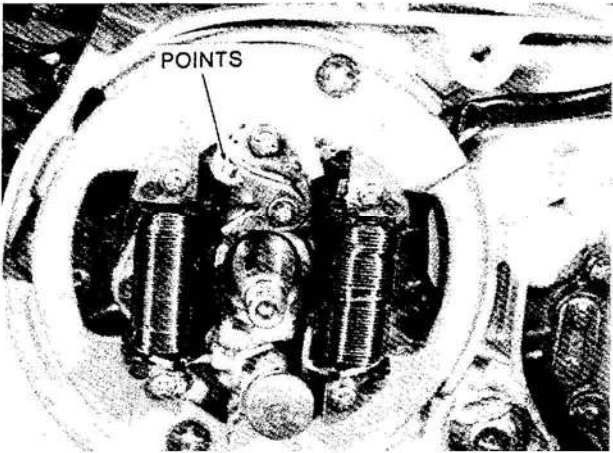

- To preset the ignition timing to minimize later adjustments, set the point gap to 0.35mm (0.014 in.) at the widest position. See ignition timing adjustment (p. 7).

RIGHT SIDE

Oil Pump

Removal:

- Take off the oil pump cover. Bend up the tab on the oil pump lever, and slip the cable off the lever.

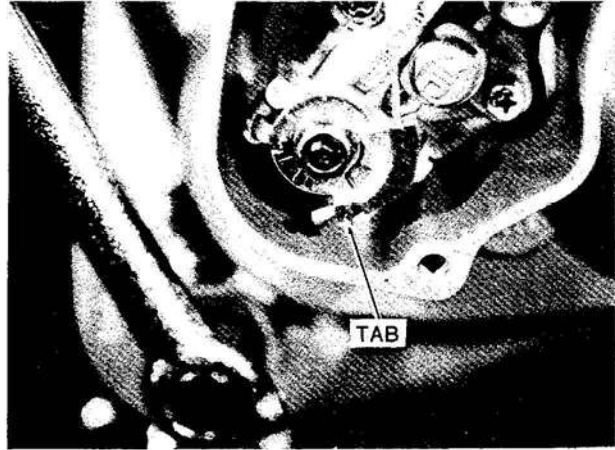

- Take off the oil pressure line banjo bolt first and then the oil feed line banjo bolt. Oil will run out of the feed line; quickly free it from the grommet and wire it up so that the open end is higher than the oil level in the tank.

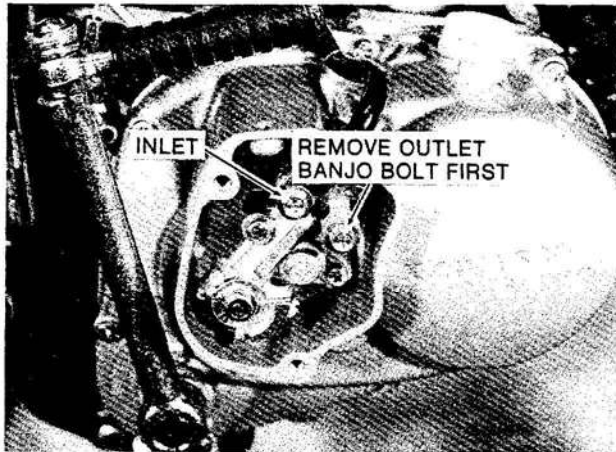

- Take out the two oil pump mounting screws, and then remove the oil pump.

Installation Notes:

- Be sure each banjo fitting has an aluminum washer on both sides. Tighten the banjo bolts to no more than 0.45 kg-m (39 lb-ins.).
- Bend back the tab on the lever to hold the cable securely in place.
- Adjust the oil pump cable (see p. 6).
- Bleed the oil pump (see p. 63).

Disassembly:

- Wrap a piece of cloth around the end of the oil pump shaft (10) to protect it, and pull it out with pliers. A copper spacer (9) will also come out.
- Pull the bushing (12) off the pump shaft. The O-ring (11) and oil seal (13), if worn or damaged, can be removed for replacement with a small hook.
- Pressing down on the plunger cap (28) so that the cap will not be thrown off by the spring inside, remove the two plunger cap screws and then the cap.
- Remove the spring seat (25), spring (24), valve sleeve stopper (27), and O-ring (26).
- Remove the cap (15) on the other side. If the O-ring needs to be replaced, it may be pulled out with a small hook.

- Insert a thin rod past the control cam, and push out the plunger follower (22), plunger (21), and valve sleeve (23).
- Remove the control lever nut (8), and remove the lever (5), lockwasher (7), washer (6), and spring (4).
- Pull out the control cam (2). If the V-ring (3) on the control cam needs to be replaced, it may be pulled off with a small hook.

Assembly Notes:

1. When putting in a new oil seal, apply oil to it and fit it in using a press.
2. Apply oil to the O- and V-rings, plunger follower, plunger, and valve sleeve before assembly.

Oil Pump

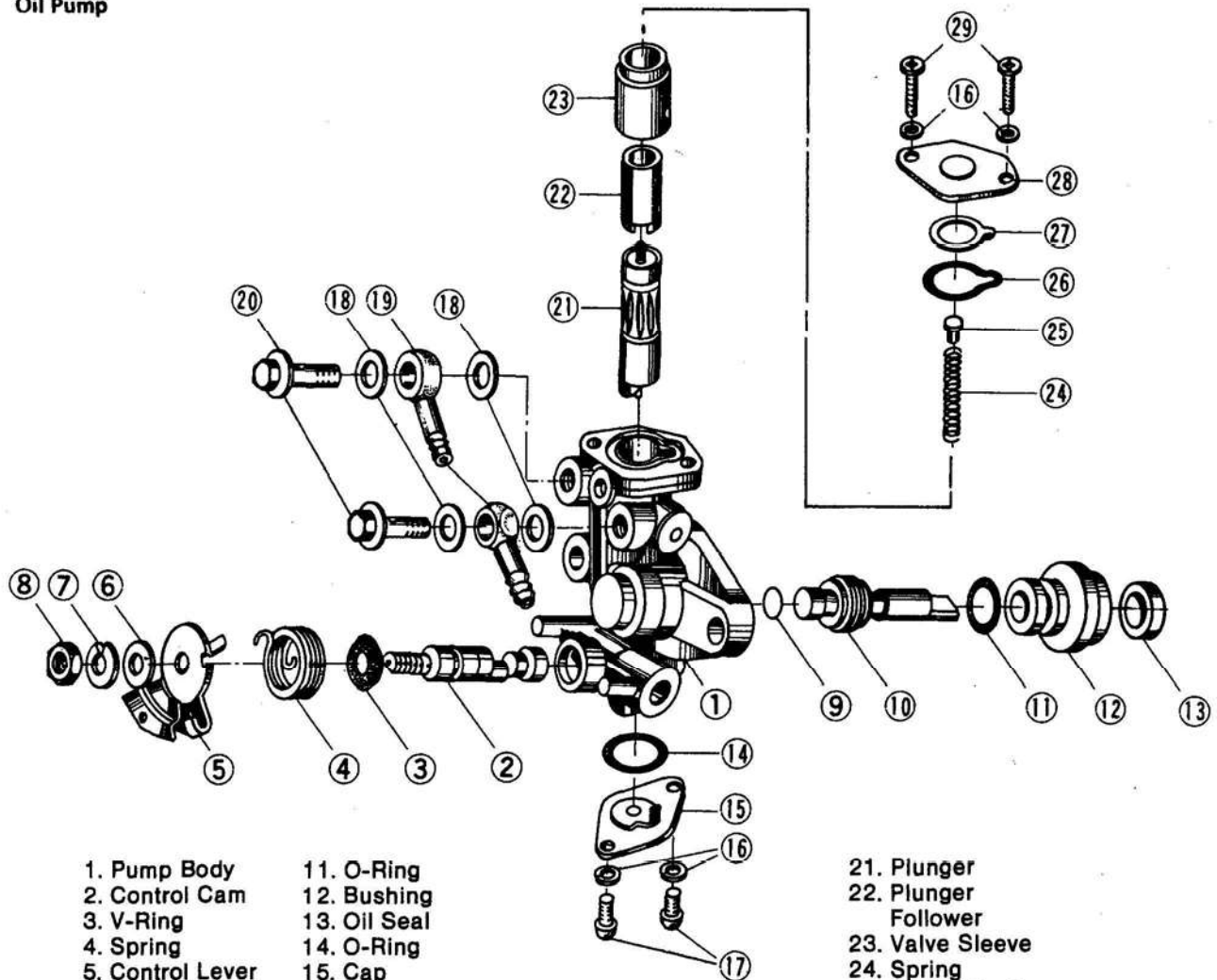

- | | |
|------------------|-----------------|
| 1. Pump Body | 11. O-Ring |
| 2. Control Cam | 12. Bushing |
| 3. V-Ring | 13. Oil Seal |
| 4. Spring | 14. O-Ring |
| 5. Control Lever | 15. Cap |
| 6. Washer | 16. Lockwasher |
| 7. Lockwasher | 17. Seat |
| 8. Nut | 18. Washer |
| 9. Spacer | 19. Connector |
| 10. Pump Shaft | 20. Banjo Bolts |

- | |
|--------------------------|
| 21. Plunger |
| 22. Plunger Follower |
| 23. Valve Sleeve |
| 24. Spring |
| 25. Spring Seat |
| 26. O-Ring |
| 27. Valve Sleeve Stopper |
| 28. Cap |
| 29. Screw |

24 DISASSEMBLY - ENGINE INSTALLED

Clutch

Removal:

- Drain the transmission oil.
- Remove the oil pump (p. 22).
- Take out the screws holding the right hand engine cover to the crankcase. Tap the cover gently with a self-faced hammer to remove it.

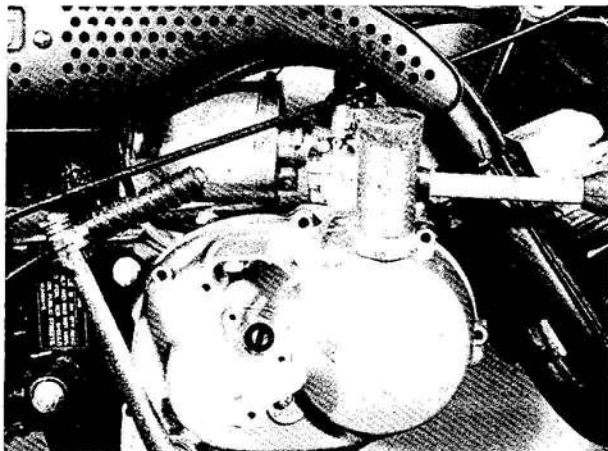

- Hold the clutch with a strap wrench and remove the clutch nut. Pull the clutch assembly straight off the shaft.

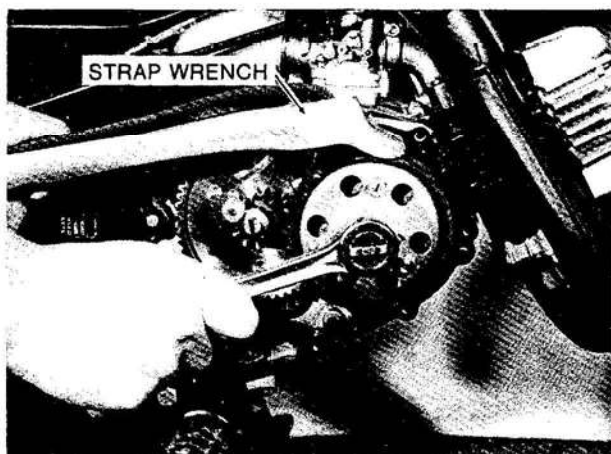

Installation Notes:

- If the key is damaged, replace it. The key drives the clutch because the shaft is not tapered.

- If the non-return needle bearing is removed, it must be installed correctly or the kickstarter will not work. The bearing must be installed in the clutch hub so that the clutch bushing will turn inside the hub counterclockwise but not clockwise, as viewed from the outside of the engine.

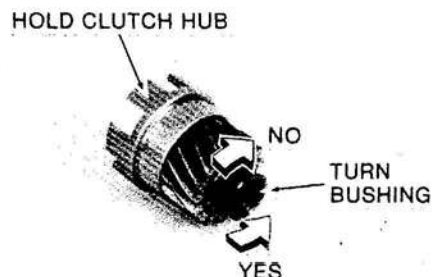

- Tighten the clutch hub nut to 4.5 - 6.2 kg-m (33 - 45 lb-ft) of torque. If the nut is not tight the kickstarter will not work.

Disassembly:

- Remove the cotter pins and tighten the three adjuster nuts just until the coils bind in the springs.

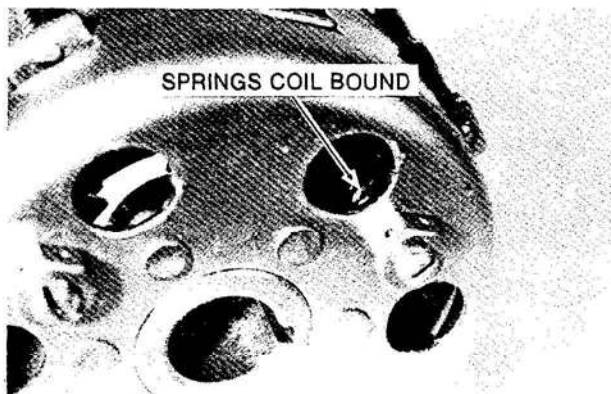

- Compress the plates slightly, and remove the large snap ring on the back of the clutch.



- Lift off the ball retainer plate and take out the sixteen 3/8 inch steel balls.
- Now remove the ball guide, the first steel plate, one friction plate, the second steel plate, another friction plate, and the four small springs.

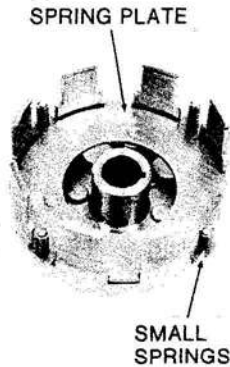

- Remove the adjustment nuts and take out the spring plate and the three large springs.

Assembly:

- Put the three large springs over the studs on the spring plate, and then set the clutch housing over them so that the studs come through the three small holes. Put on the nuts and tighten them until the springs are coil bound.
- Put the four small springs over the four small pins on the spring plate.

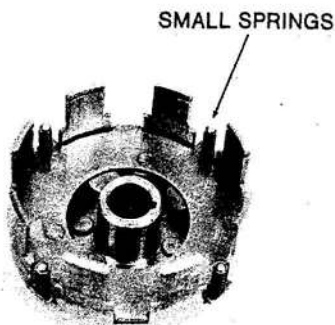

- Put one friction plate in place. Both friction plates are the same and are the same on both sides. They may be put in either way. Put in the second steel plate.

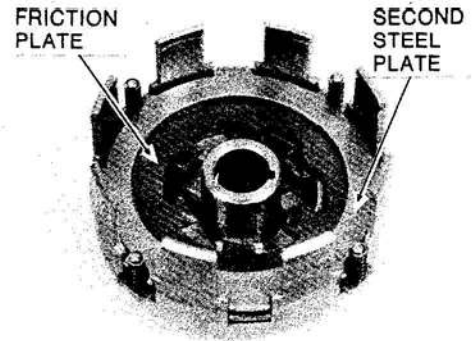

- Put in the other friction plate, and the first steel plate. note that the raised lip around the inner edge of the first steel plate must be toward the engine when the clutch is installed.

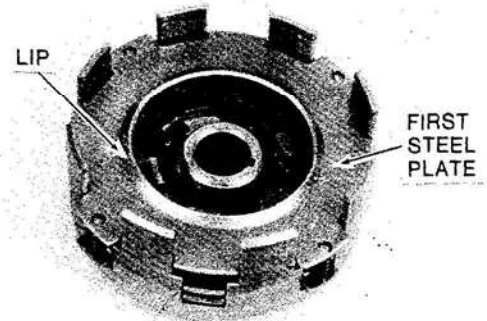

- Install the ball guide, as shown, and then put in the sixteen 3/8 inch steel balls.

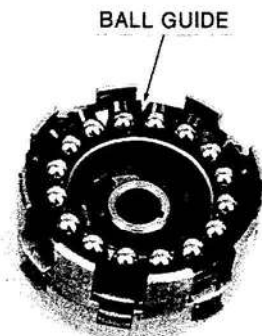

26 DISASSEMBLY - ENGINE INSTALLED

- Set the ball retainer plate over the balls and press it down slightly while installing the large snap ring.

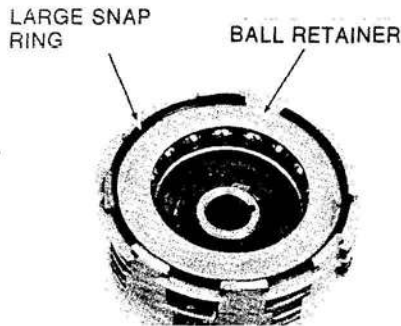

- Loosen the adjuster nuts until they turn freely. Tighten all of them finger-tight, and then turn them evenly until the proper clearance is achieved as shown. Insert the cotter pins from the "inside" and bend the ends around each nut.

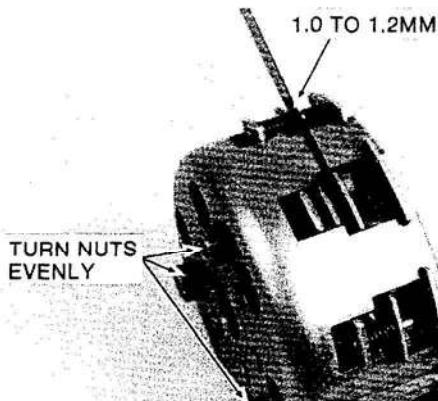

Shift Mechanism Removal:

- Take off the shift pedal. Carefully remove any burrs around the end of the shaft.
- Remove the clutch (p. 24).
- Put the transmission in gear and lock the rear brake to remove the input shaft gear.

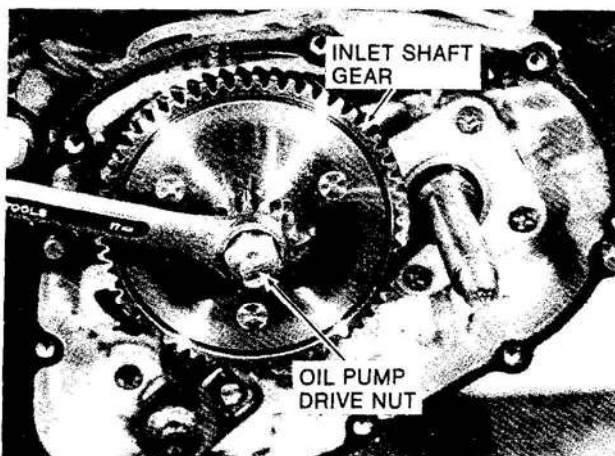

- Compress the ratchet mechanism and pull the shift shaft out of the crankcase.

Installation Notes:

- The large input shaft gear must go on with the recessed side toward the crankcase. The small gear can go on either way.

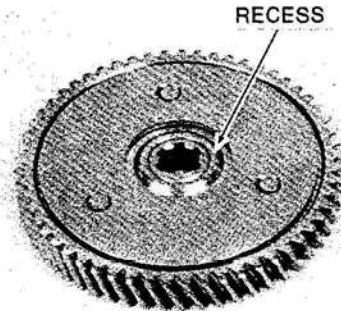

- Tighten the input shaft gear nut to 5.4 - 7.5 kg-m (39 - 54 lb-ft) of torque. The end of this nut drives the oil pump. If it loosens in use, the engine may be damaged by lack of lubrication.

Kickstarter Removal:

- Remove the kickstarter lever.
- Remove the oil pump (p. 22).
- Take out the screws holding the right hand engine cover to the crankcase, and remove the cover.
- Use circlip pliers to remove the circlip and washer on the kickstarter shaft.

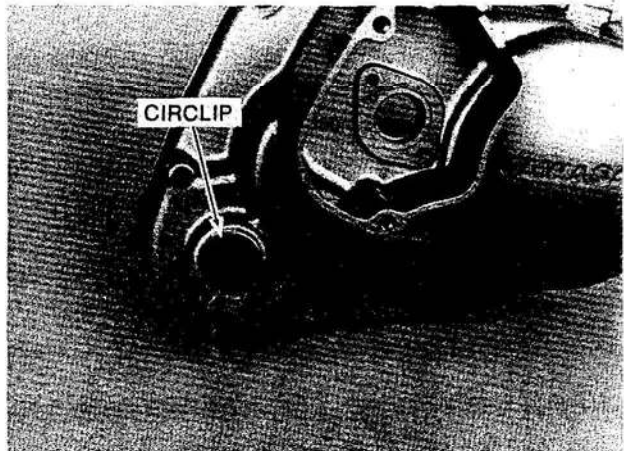

- From the outside push the kickstarter shaft into the cover about 6mm (1/4 in.). This will allow the spring to unwind without flying loose. Pull the kickstarter shaft out.

Installation:

- Slip the shaft into the right hand engine cover from the inside so that the hook on the end of the spring fits into the hook in the cover. The kickstarter should not yet fit all the way into place.

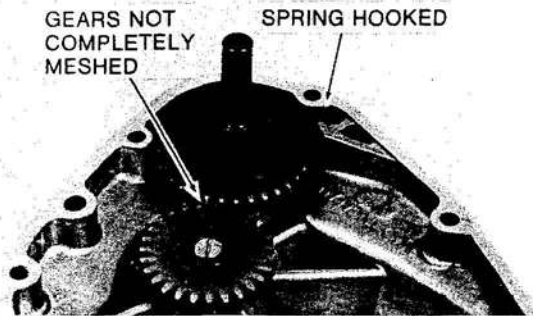

- Slip the kickstarter lever onto the end of the shaft and turn the shaft clockwise (as seen from the inside) and press the kickstarter all the way into position.

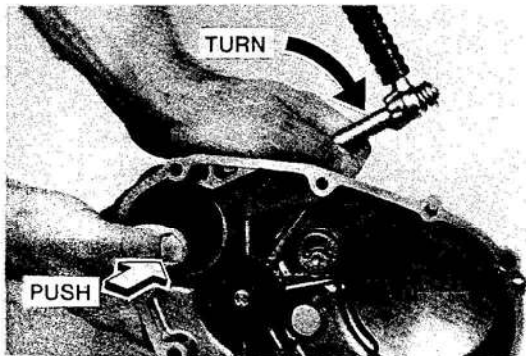

- Be sure the O-ring is in place in the right hand engine cover and put on the flat washer and a new circlip.
- Install the engine cover.
- Install the oil pump (p. 22).
- Adjust the oil pump (p. 6).
- Install the kickstarter pedal at the angle shown.

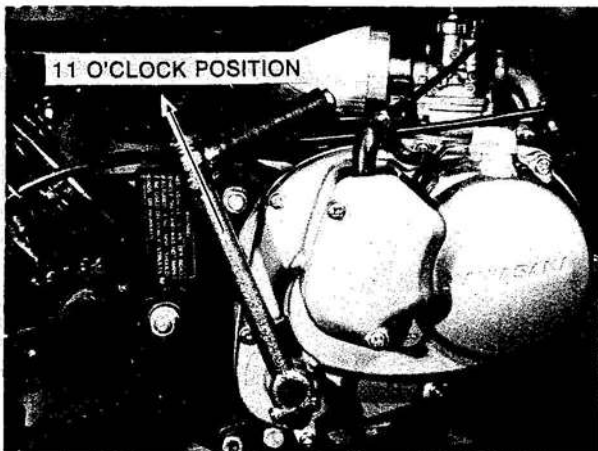

Disassembly:

- Remove the circlip, the spring washer, the spring, and the kickstarter gear holder plate.

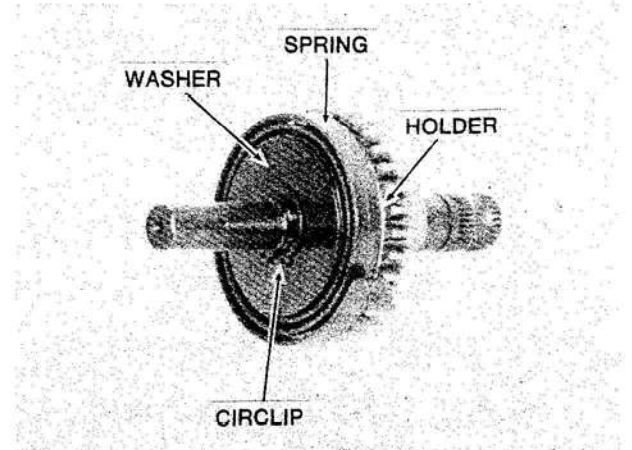

- Slip the ratchet mechanism off the splines.
- Hold the pawl down and take off the kickstarter gear.

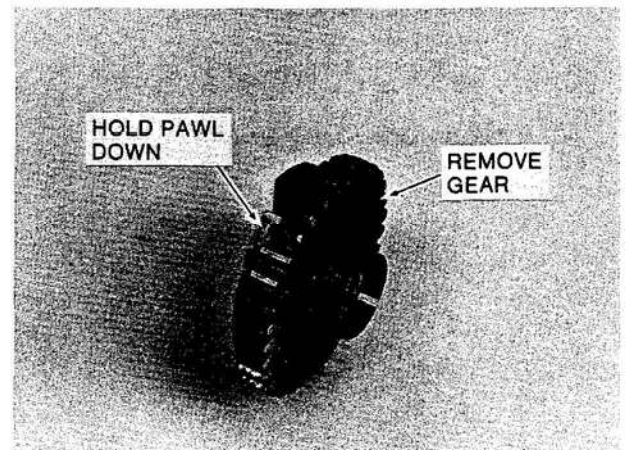

- Remove the pawl by holding it down slightly and sliding it out to the side. The pawl pin is spring-loaded. Drop out the pawl pin and its spring.

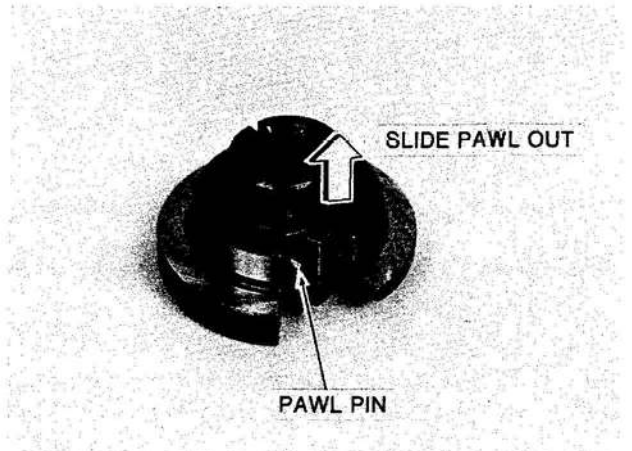

28 DISASSEMBLY - ENGINE INSTALLED

Assembly:

- Be sure all parts are clean and free of metal chips or other debris.
- Put the pawl pin spring and pawl pin into the hole. Slip the pawl into place.



- Put the spring on so that the inside end of the spring fits into the slot in the ratchet mechanism. The hook on the outer end of the spring must be aligned as shown.

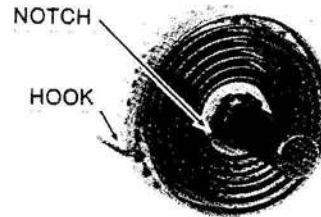

- Press down the pawl and slip the kickstarter gear over it. Note how the pawl fits into the notches in the kickstarter gear.

- Put on the spring washer and a new circlip.

PAWL MUST FIT NOTCH



- The kickstarter gear holder plate fits onto the shaft next, as shown.

HOLDER PLATE

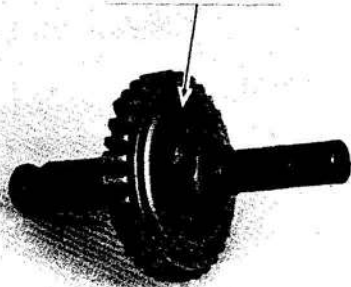

DISASSEMBLY - ENGINE REMOVED

TABLE OF CONTENTS

Engine Removal	30
Crankcase Splitting.....	30
Transmission.....	31
Shift Drum.....	32
Drive Shaft	32
Output Shaft.....	33
Crankshaft	35
Crankcase and Bearings.....	35

30 DISASSEMBLY - ENGINE REMOVED

ENGINE REMOVAL

Removal:

- Drain the transmission. Remove both drain plugs.
- Pull the spark plug wire off the spark plug.
- Remove the carburetor (p. 16).
- Remove the muffler (p. 18).
- Remove the oil pump cable (p. 22).
- Take out the oil pump inlet line banjo bolt. Oil will run out. Quickly raise the open end of the oil line above the level the oil in the tank and wire it there.
- Loosen the cylinder stay bolts. Take off the nuts, but leave the bolts in place.

KAWASAKI



- Loosen both engine mount bolts. Hold the engine up and remove both engine mount bolts and the cylinder stay bolt.

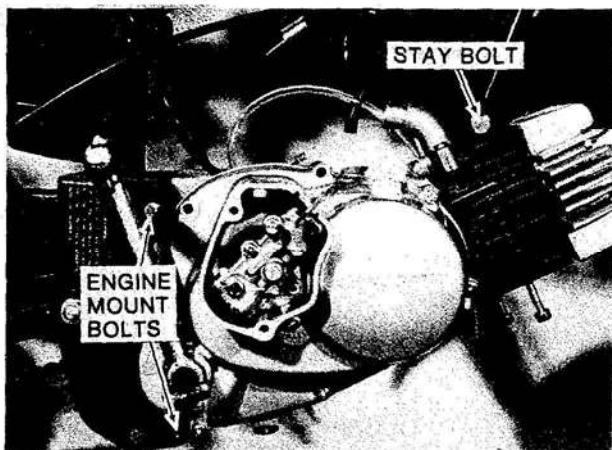

- Lower the engine out of the frame.

Installation:

- Slip the rear of the engine between the mounting tabs on the frame. Put in the mount bolts and the cylinder stay bolt. Tighten the engine mount bolts to 2.6 - 3.5 kg-m (19 - 25 lb-ft) of torque, and both the cylinder stay bolts to 1.4 - 1.9 kg-m (10.0 - 13.5 lb-ft).

- Connect the oil inlet to the oil pump.
- Fasten the oil pump cable to the pump control lever. Be sure to bend the tab over so the cable cannot come loose (p. 22).
- Install the carburetor (p. 17).
- Install the muffler (p. 18).
- Push the spark plug cap onto the spark plug with a twisting motion.
- Inspect the oil drain plug gasket and replace it if it is damaged or shows signs of previous leakage. Install the drain plug with its gasket and tighten it securely.
- Fill the transmission with 0.6 liter (0.63 U.S. qt.) of good quality SAE 10W-30 or 10W-40 motor oil marked SE. When the transmission is full, oil will just begin to run out of the oil level inspection screw hole in the right hand engine cover.



- Adjust the oil pump cable (p. 6).
- Bleed the oil pump (p. 63).

CRANKCASE SPLITTING

Disassembly:

- Remove the clutch (p. 24).
- Take out the shift mechanism (p. 26).
- Remove the magneto stator (p. 21).
- Take off the engine sprocket (p. 20).
- Remove the engine (p. 30).
- Remove the cylinder (p. 18).
- Remove the piston (p. 19).
- Take out the nine Phillips head screws that hold the case halves together

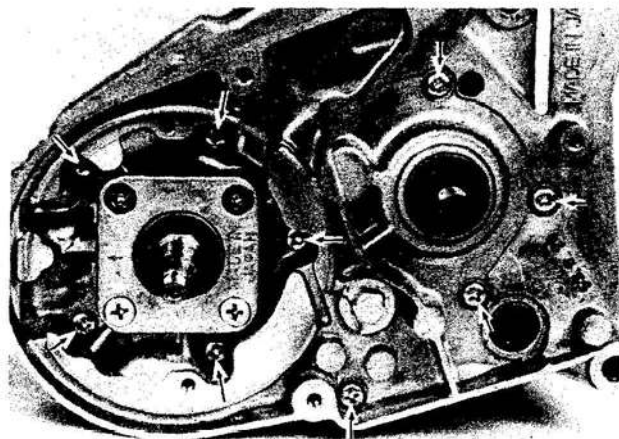

- Hold the engine in an appropriate stand with the left side down and separate the crankcase halves with a crankcase splitter.

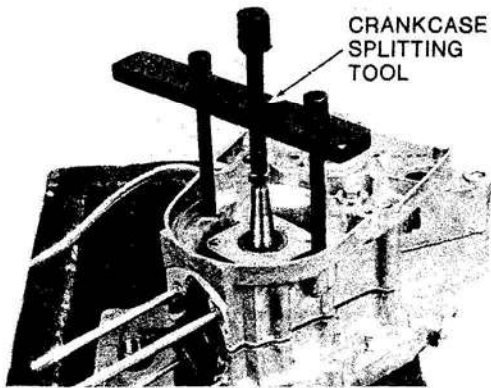

- Separate the case halves so that the crankshaft and transmission internals remain in the left hand half.

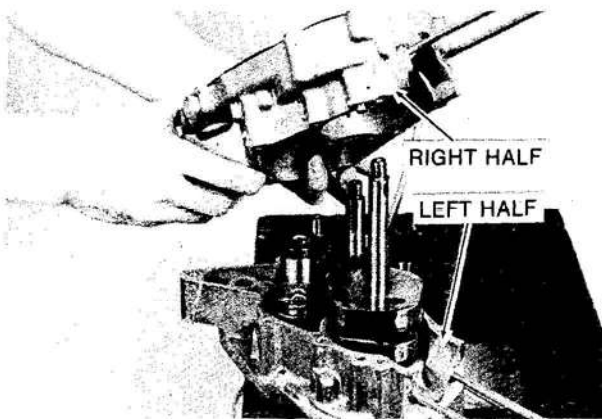

Assembly:

- Clean the mating surfaces of the crankcase halves thoroughly.
- Be sure all transmission parts and the crankshaft are installed in the right hand crankcase half.
- Be sure the two locating dowels are in place in the right case half.
- Lightly coat the mating surfaces of the left hand crankcase half with Kawasaki Liquid Gasket (P/N 92104-102), and set the left half over the right half. Tap it lightly with a soft-faced hammer to settle the halves together.
- Put in the nine crankcase screws and tighten them securely.
- Install the piston with its rings (p. 19).
- Replace the cylinder and head (p. 18).
- Mount the engine in the frame (p. 30).
- Replace the engine sprocket and magneto stator (p. 21).
- Replace the shift mechanism and clutch (p. 24).
- Adjust the oil pump cable (p. 6).
- Bleed the oil pump (p. 63).
- Adjust the ignition timing (p. 7).

TRANSMISSION

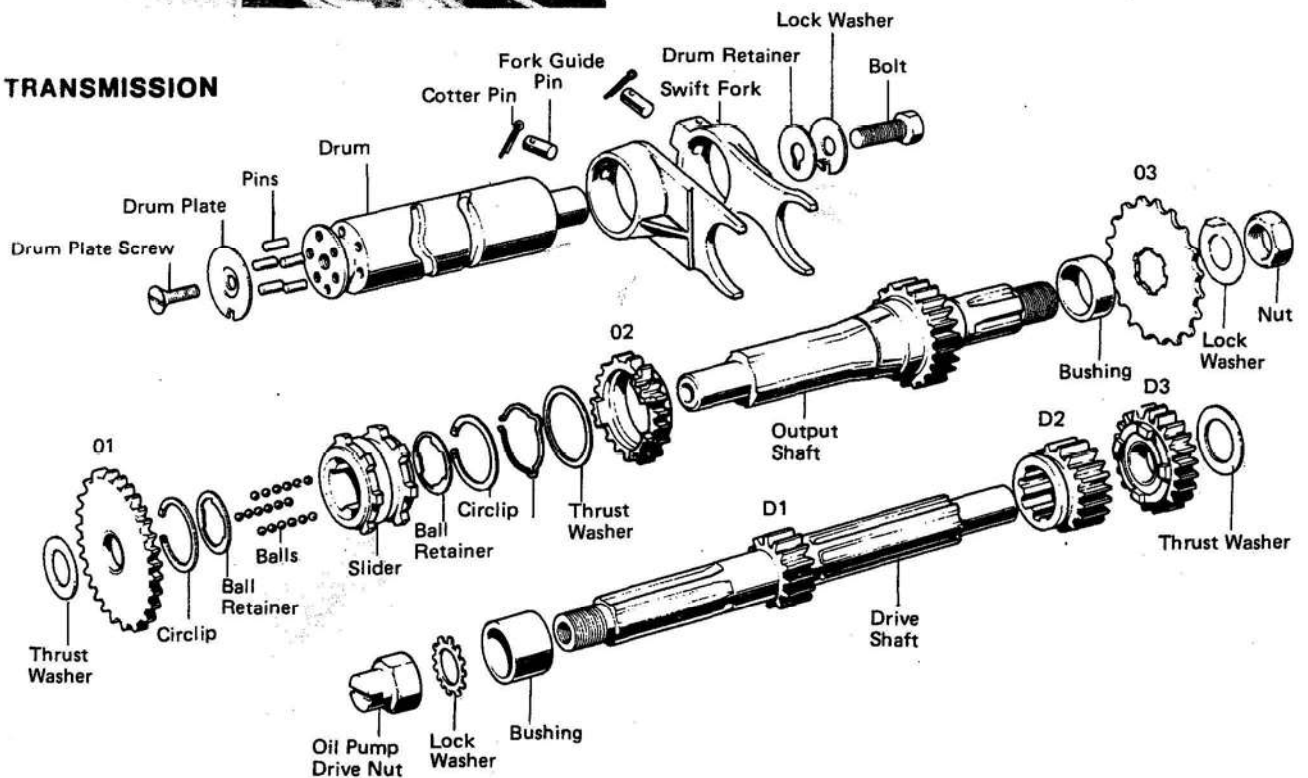

32 DISASSEMBLY - ENGINE REMOVED

Shift Drum

Removal:

- Split the crankcase (p. 30).
- Lift the transmission shafts and drum out of the left hand crankcase half as a unit.

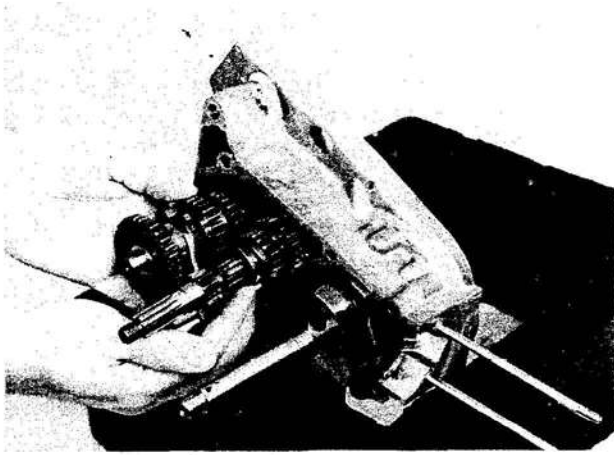

- Pull the cotter pins out of the shift forks and remove the locating pins. Slide the shift forks off the drum.

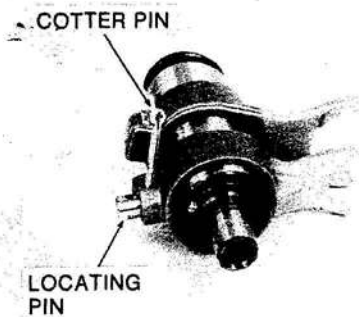

- Take the screw out of the end of the shift drum, and then remove the retainer plate. The pins in the end of the drum will fall out.

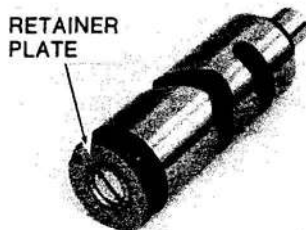

Installation Notes:

- Stake the head of the shift drum screw after tightening it securely, or use a thread locking compound on it.
- Be sure to use new cotter pins on the shift forks. If a locating pin were to fall out during use, the transmission could shift into two gears at once, causing the transmission to lock with the possibility of extensive damage.
- On late models, install the drum locator plate with the "K" mark toward the small end of the drum.

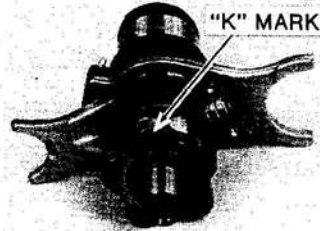

Drive Shaft

Removal and disassembly:

- Split the crankcase (p. 30).
- Lift the transmission shafts and drum out of the left hand crankcase half as a unit.

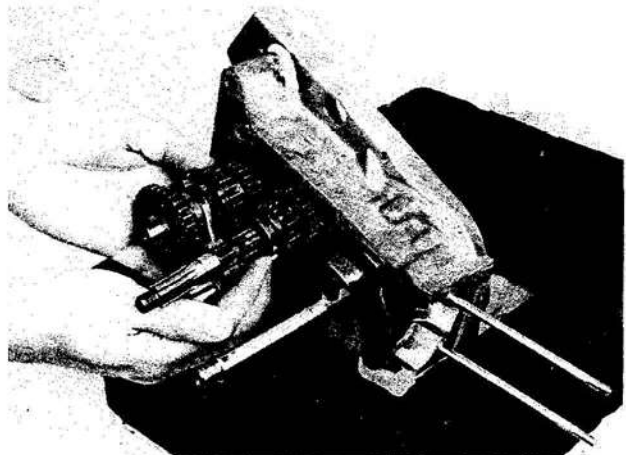

- Two of the gears may be slid off the shaft. The small gear is part of the shaft.

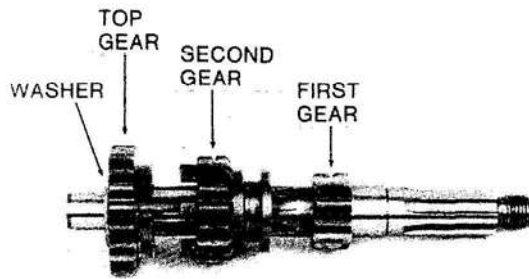

- Put the washer onto the shaft next to top gear.

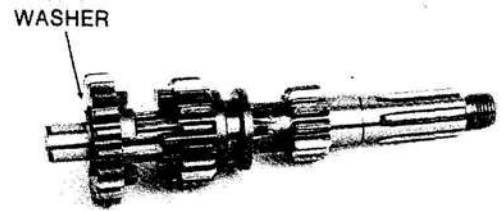

Assembly and Installation:

- Inspect the shaft and gears for damage and discoloration. Slight damage may be repaired with a stone. More extensive damage, cracks, or broken or missing teeth, require replacement of the part.
- Fit 2nd gear (17 teeth) to the splines of the non-threaded end of the shaft. The fork slot side goes on first.

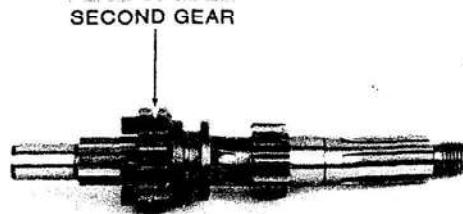

- Gather the two transmission shafts and the shift drum with its forks into a bundle in the same relative positions they occupy in the engine and then fit them into the left hand crankcase half.



- Slip top gear (21 teeth) onto the non-threaded end of the shaft. The side with the engagement dogs faces 2nd gear.

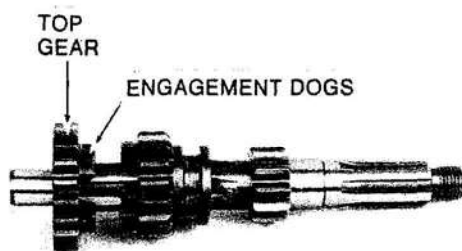

- Assemble the crankcase (p. 31).

Output Shaft

Removal and Disassembly:

- Split the crankcase (p. 30).
- Lift the transmission shafts and drum out of the left hand case half as a unit.



34 DISASSEMBLY - ENGINE REMOVED

- Slip the washer and 1st gear off the non-threaded end of the shaft, and take the bushing off the other end.

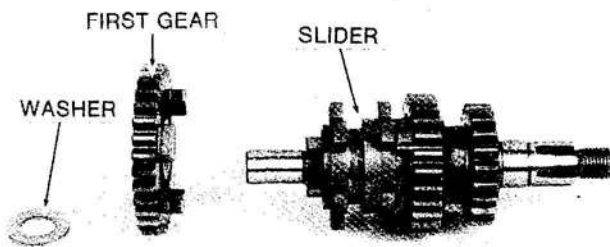

- Slip 2nd gear onto the non-threaded end of the shaft. Put on the thrust washer and a new circlip.

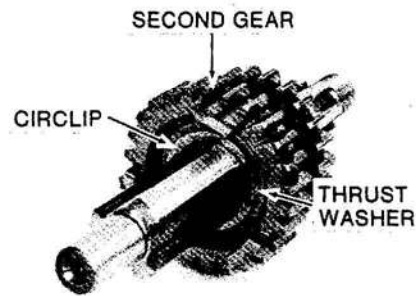

- Carefully remove the slider with its thirty (30) 5/32 inch steel balls.
- Remove the circlip, the thrust washer, and 2nd gear. Top gear is a part of the shaft.

- Remove the circlip and ball retainer from the short end of the slider. Put the slider onto the shaft, long end first, and turn it to leave equal space between the splines. Drop 5 of the 5/32 inch steel balls into each slot between the splines of the slider and the shaft.

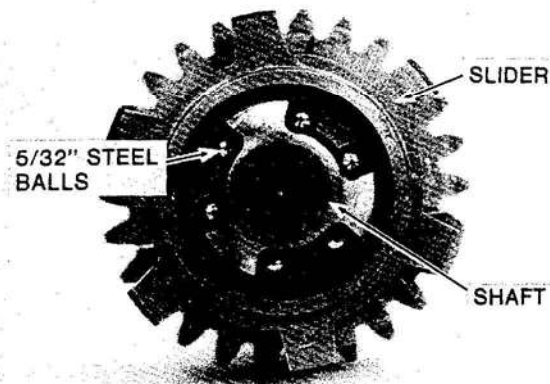
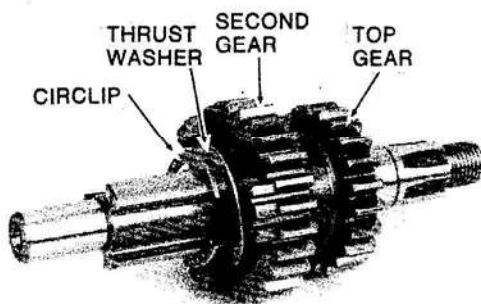

- Put on the ball retainer, and then put a new circlip into the slot in the slider.

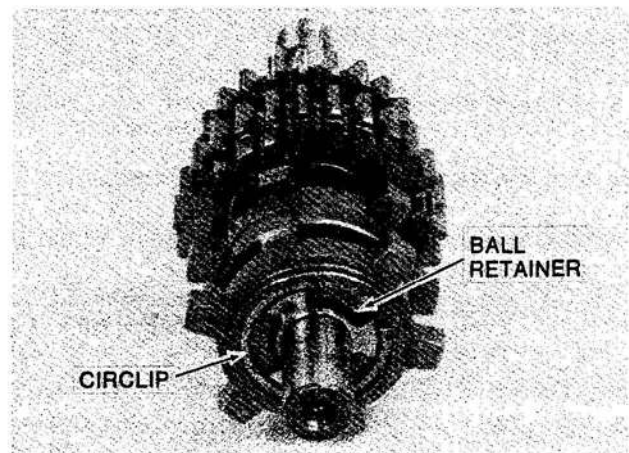

Assembly and Installation:

- Inspect the shaft and gears for damage and discoloration. Slight damage may be repaired with a stone. More extensive damage, cracks, or broken or missing teeth require replacement of the part.

- Put 1st gear and the washer on the non-threaded end of the shaft. The dogs on 1st gear must face the slider.

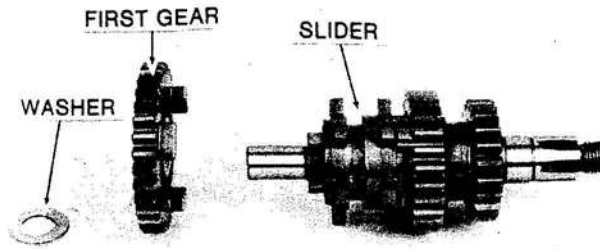

- Gather the two transmission shafts and the shift drum with its forks into a bundle in the same relative positions they occupy in the engine, and then fit them into the left hand crankcase half.

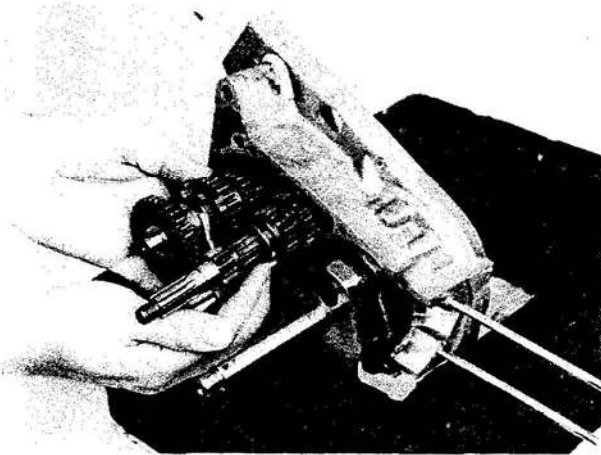

- Assemble the crankcase (p. 31).

Crankshaft Removal:

- Split the crankcase (p. 30).
- Remove the clutch drive key and the oil seal collar, and then tap the end of the crankshaft to remove it from the crankcase half.

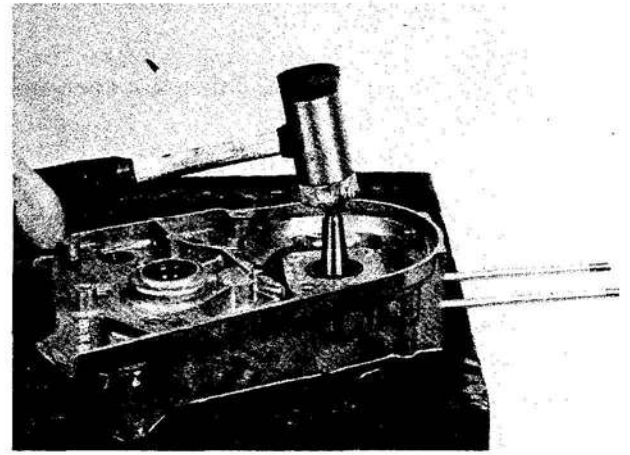

- If the connecting rod set is to be replaced, disassemble the crankshaft with a hydraulic press.

Installation:

- Assemble the crankshaft with a hydraulic press. Standard side clearance for the connecting rod big end is 0.25 - 0.30mm. See page 54 for more complete crankshaft rebuilding specs.
- Push the straight (untapered) end of the crankshaft into its bearing in the right hand crankcase half.
- Assemble the crankcase (p. 31).
- Put the oil seal collar onto the right hand end of the crankshaft and slip it into the oil seal.

Crankcase and Bearings

Removal:

- Split the crankcase (p. 30).
- Remove the crankshaft (p. 35), and the transmission shafts.
- Take out the four screws holding each crankshaft bearing retainer to each crankcase half, and remove the bearing retainers.

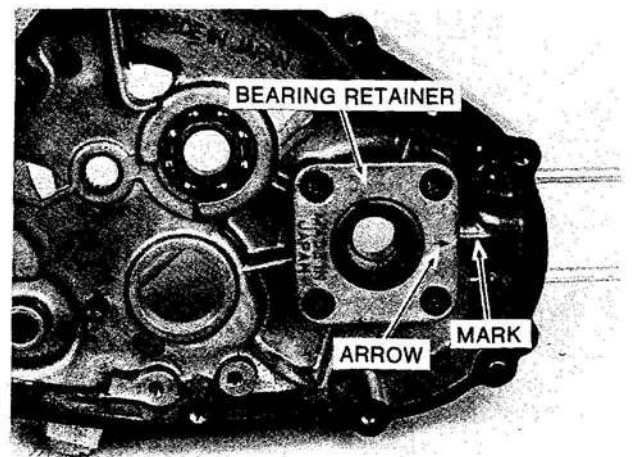

36 DISASSEMBLY - ENGINE REMOVED

- Remove the oil seals from the bearing retainers and the left crankcase half with a seal driver.

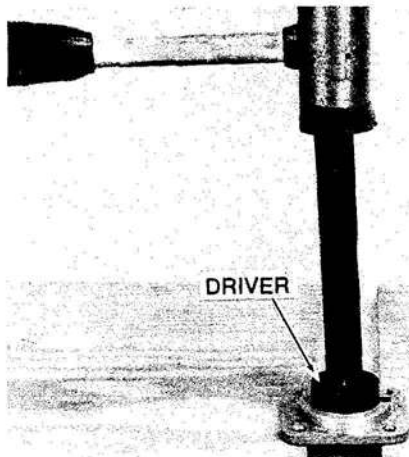

- The bearings may have to be pressed out of the case halves. Heat the crankcase to allow easier removal.

Installation:

- Press the seals into place in the bearing retainers with the same driver used to remove them. The flat side of the seal must face away from the engine. Seal No. TB24358 goes on the right hand side of the engine; seal No. TB20358 goes on the left.

FLAT SIDE FLUSH

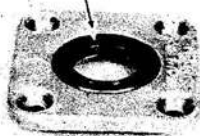

- Heat each crankcase half and cool the bearings before installing the bearings in the case halves. Be sure the bearings seat against the shoulders in the case halves.

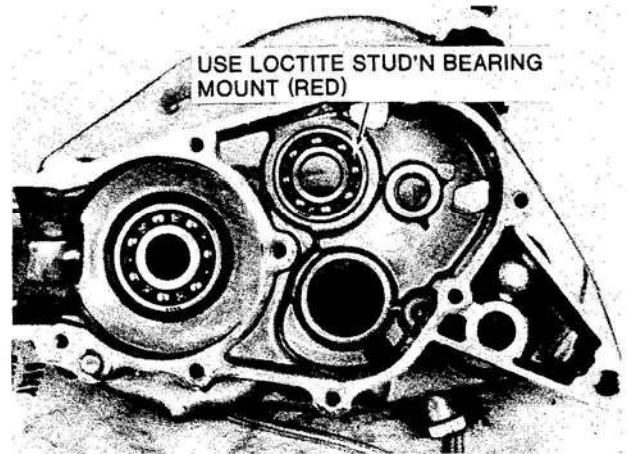

Crankcase Bearings

Crankcase Half	Bearings		
	Crankshaft	Drive Shaft	Output Shaft
Right	6203	Needle Bearing	6203
Left	6204	6203	Needle Bearing

- Coat the outside of each oil seal with a light film of oil and then press each one into its hole in the left crankcase half. The flat side of each seal should face the outside of the engine.

Left Crankcase Half Seals

Output Shaft	Drive Shaft	Shift Shaft
SB22327	VB14246	SB12205

- Install the crankshaft in the right hand crankcase half (p. 35).
- Install the transmission shafts and shift drum in the same case half (p. 33).
- Assemble the crankcase (p. 31).
- Be sure to install the bearing retainers as shown, with the arrow aligned with mark on the crankcase.

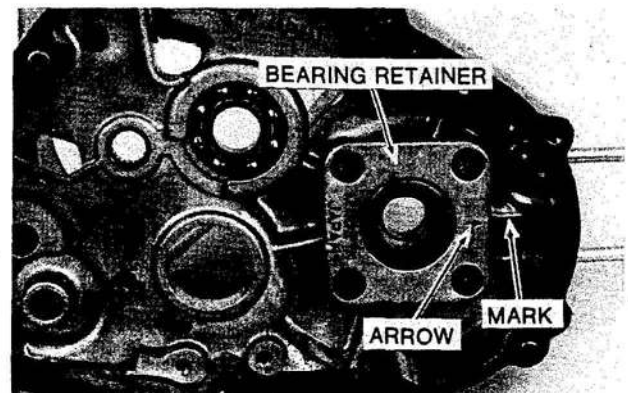

DISASSEMBLY - CHASSIS

TABLE OF CONTENTS

WHEELS AND BRAKES	38
Front Wheel	38
Rear Wheel.....	39
Brakes	40
Tires, Tubes	41
CABLES.....	41
Throttle	41
Front Brake	42
Rear Brake.....	42
LIGHTS	42
Headlight.....	42
Tail Light.....	43
SWITCHES	44
STEERING	44
Handlebars.....	44
Steering Stem Bearings.....	45
SUSPENSION AND DRIVE CHAIN	45
Front Fork.....	45
Rear Suspension	46
Drive Chain.....	46

DISASSEMBLY — CHASSIS

WHEELS AND BRAKES

Front Wheel

Removal:

- Remove the adjuster from the lower end of the front brake cable.

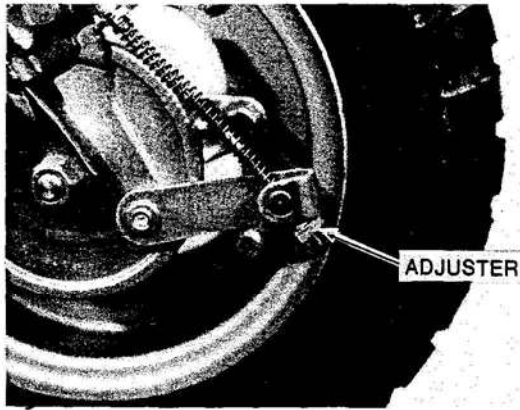

- Take out the bolt holding the brake panel to the lower fork leg.

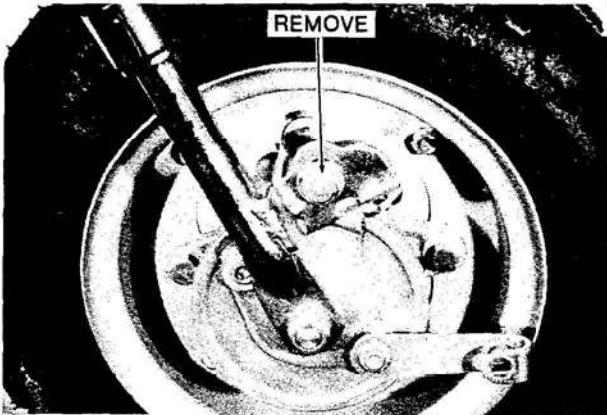

- Remove the axle nut and washer, and then pull the axle out, using a support under the engine to allow the front wheel to drop out. Two axle collars (spacers) will come out with the wheel.

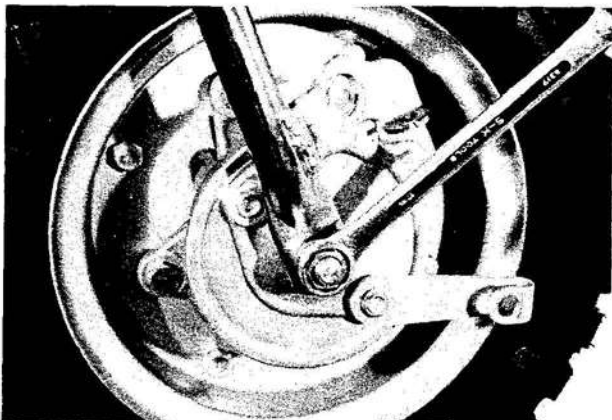

Installation Notes:

- Be sure to include the two axle collars.
- Tighten the axle nut to 4.5 - 6.2 kg-m (32.5 - 44.8 lb-ft) of torque.
- Adjust the front brake.

Front Hub Disassembly:

- Pull the brake panel assembly out of the brake drum and then remove the four bolts with lockwashers that hold the drum to the hub.

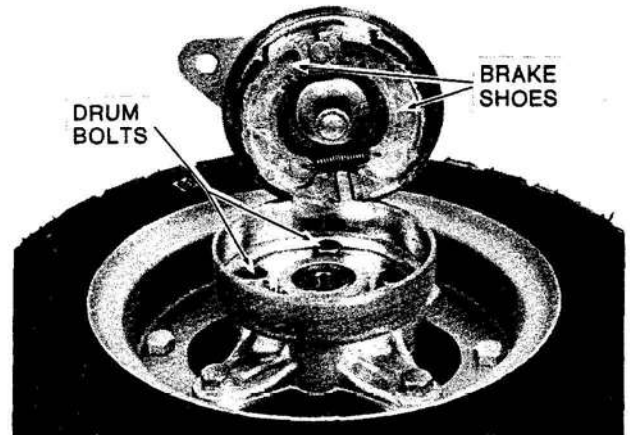

- Remove the bearings with a long pin punch and a hammer. Be sure the end of the punch does not damage the bearing balls or the ball holder.

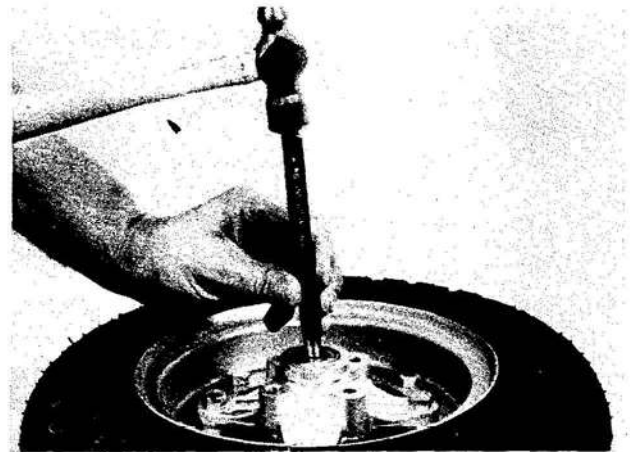

Assembly Notes:

- Press the bearings into place with a bearing driver. Be sure the spacer is in place between the bearings.

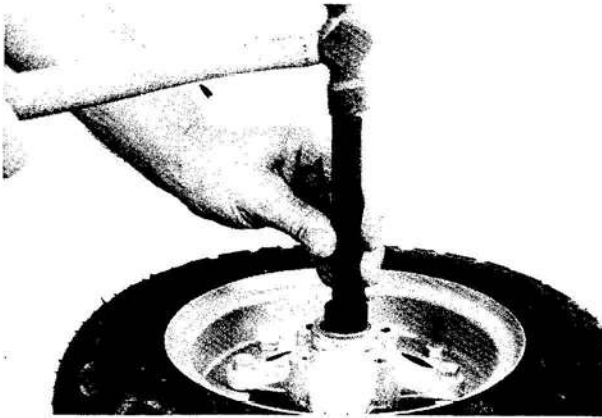

- Tighten the brake drum bolts to 3.0 kg-m (22 lb-ft) of torque.

Rear Wheel

Removal:

- Support the motorcycle with the rear wheel off the floor.
- Remove the drive chain master link.

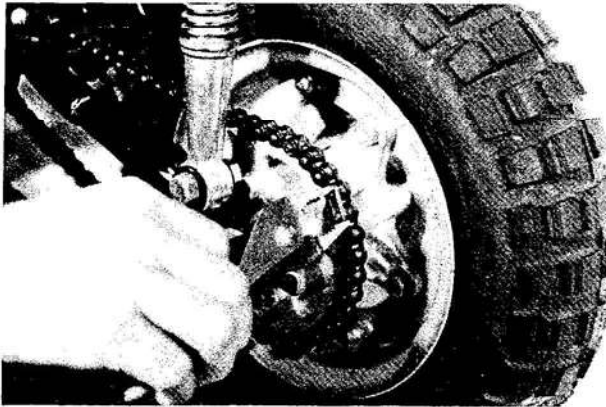

- Take out the torque link bolt, and then remove the brake adjuster and pull the cable out of the holder on the back plate.

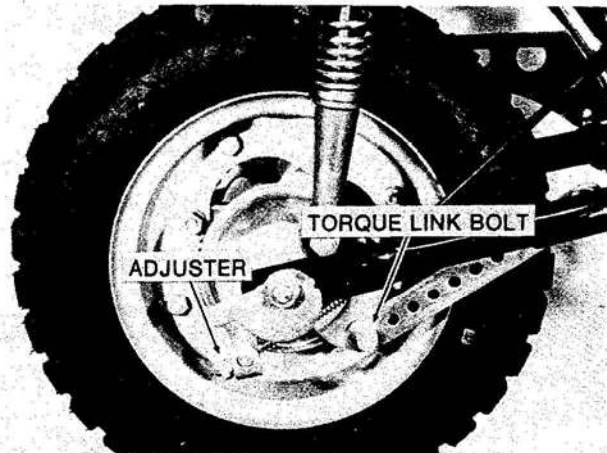

- Unscrew the rear axle nut and pull out the rear axle. Drop the rear wheel out of the frame.

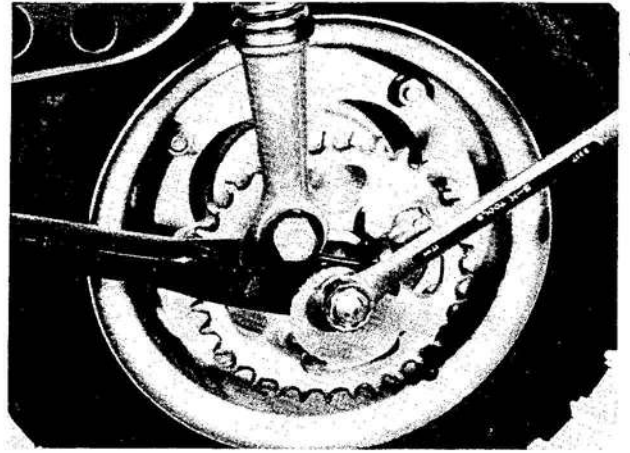

Installation Notes:

- The axle spacers are the same on both sides of the hub.
- Tighten the torque link bolt to 3.0 - 3.5 kg-m (21.6 - 25.3 lb-ft) of torque.
- Torque the rear axle nut to 4.5 - 6.2 kg-m (32.5 - 44.8 lb-ft).
- Mount the drive chain master link clip so that the open end of the clip points away from the direction of chain travel.

Master Link Installation

Direction of Chain Rotation

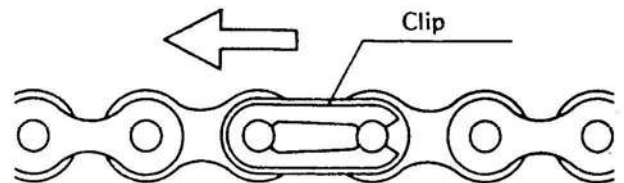

- Adjust the rear brake (p. 9).

Rear Hub Disassembly:

- Remove the four bolts with lockwashers from the sprocket.

40 DISASSEMBLY - CHASSIS

- Pull the brake panel out of the brake drum. Take out the four bolts with lockwashers that hold the drum to the hub.

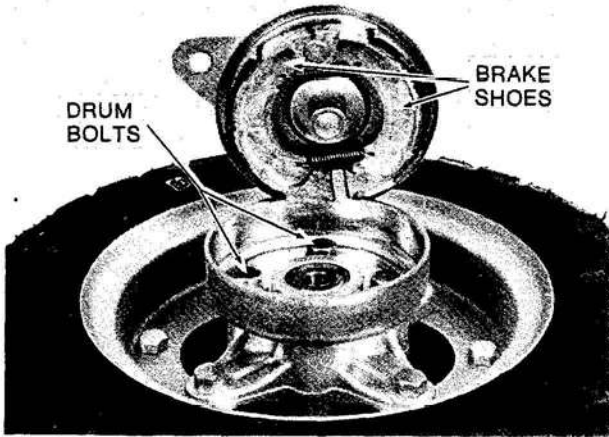

- Remove the bearings with a long punch and a hammer. Be sure the end of the punch does not hit the bearing balls or ball holder.

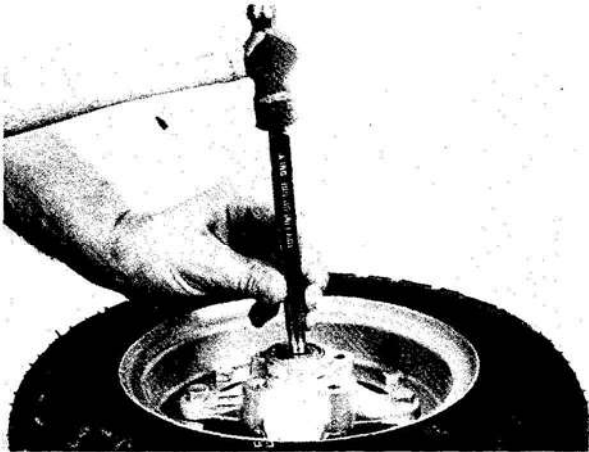

Assembly Notes:

- Press the bearings into place with a bearing driver. Be sure the spacer is in place between the bearings.



- Tighten the sprocket and brake drum bolts to 3.0 kg-m (22 lb-ft of torque.)

Brakes

Disassembly:

- After removing the front wheel (p. 38) or rear wheel (p. 39), pull the brake panel out of the brake drum.

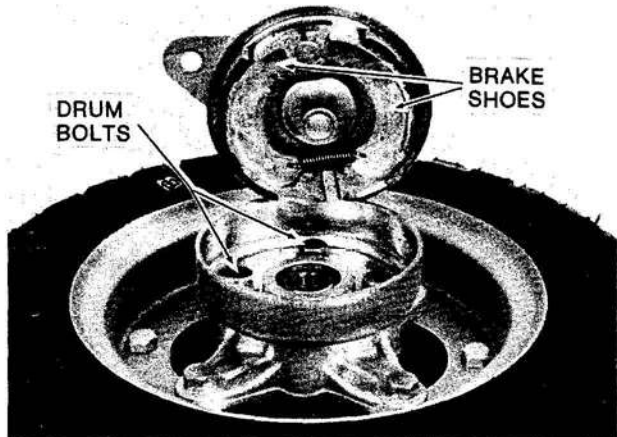

- Grasp the brake shoes, one in each hand, and tip them upwards and together to remove them.

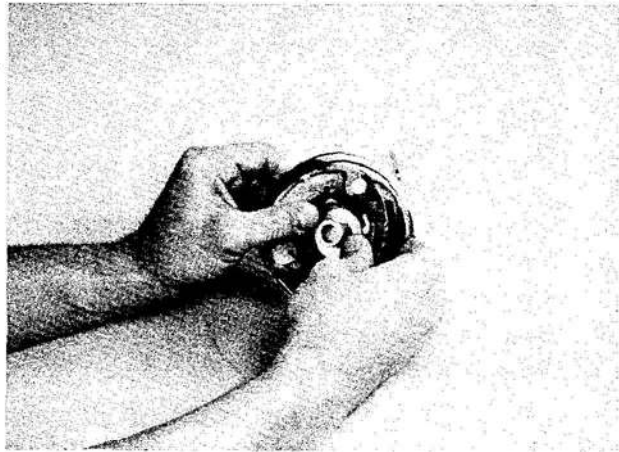

- Remove the springs to separate the two shoes.

Assembly Notes:

- Be careful not to get any oil or grease on the brake shoe linings during installation.
- Check the drum to be sure there are no foreign objects or debris in it, before fitting the brake panel assembly into the drum.

Tires, Tubes**Removal:**

- Remove the front wheel (p. 38). or the rear wheel (p. 39).
- Remove the brake panel and drum (p. 40).
- Let all the air out of the tire.

WARNING If the tire is not completely deflated before the wheel bolts are loosened, the halves of the wheel may suddenly and forcefully fly apart during disassembly.

- Remove the four bolts that hold the hub to the rim and the four remaining bolts that hold the halves of the rim together.

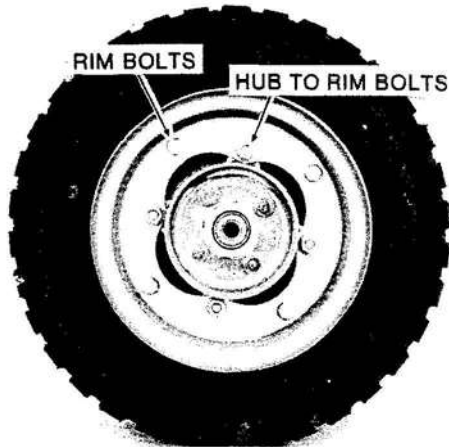

- Separate the halves of the rim and remove the tire and tube.

Installation Notes:

- To help assure that the tube is not pinched between the halves of the rim during installation, partially inflate the tube inside the tire before joining the halves of the rim.
- Tighten the four bolts that hold the hub to the rim to 2.55 - 3.5 kg-m (18.4 - 25.3 lb-ft) of torque. If the four bolts holding the rim halves together are 10mm bolts ('75 models and later), tighten them to 2.55 - 3.5 kg-m (18.4 - 25.3 lb-ft) of torque. If they are 8mm bolts ('74 models and earlier), tighten them to 1.35 - 1.85 kg-m (9.8 - 13.4 lb-ft) of torque.

CABLES**Throttle Cable****Removal:**

- Take off the oil pump cover, and then bend up the tab on the oil pump cover to free the end of the cable. Unscrew the cable fitting in the top of the oil pump housing.

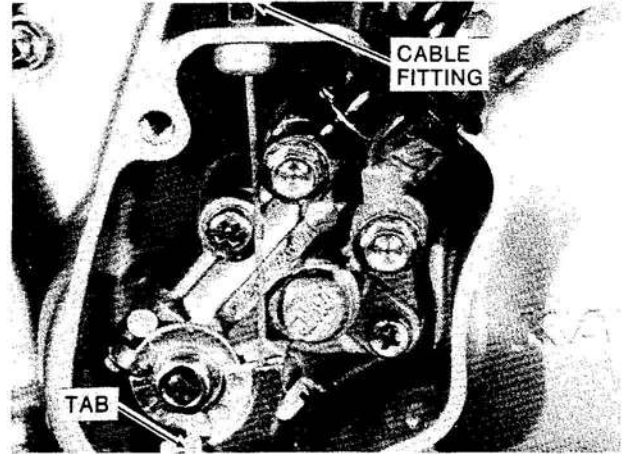

- Unscrew the carburetor mixing chamber cap, and pull the slide assembly out of the carburetor.

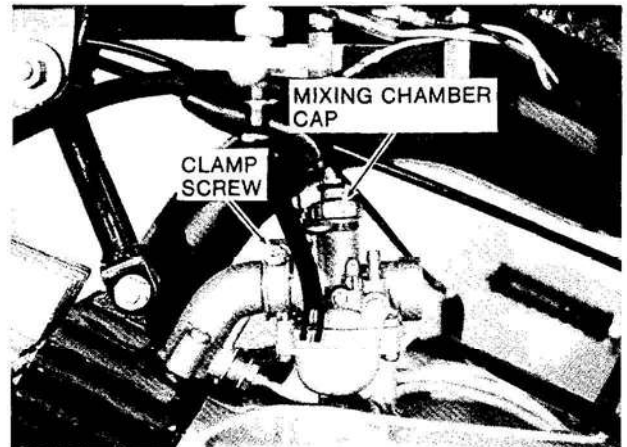

- Free the cable end from the slide through the keyhole slot.



- Remove the cable adjusters from the mixing chamber cap, and then pull the cable from the front of the motorcycle until it is free of the forks.

42 DISASSEMBLY - CHASSIS

- Remove the twist grip screws and separate the halves. Take the cable nipple out of the notch in the twist grip reel, and then unscrew the cable adjuster from the lower case half.

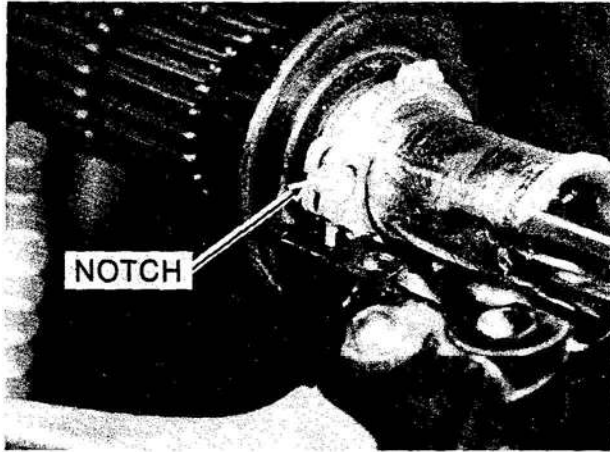

Installation Notes:

- Lightly grease the cable reel in the twist grip during assembly.
- Adjust the cable (p. 5).
- Be sure all rubber caps are back in place to prevent dirt from entering the carburetor.

Front Brake Cable

Removal:

- Remove the adjuster at the brake panel, and then pull the cable free of the holder.

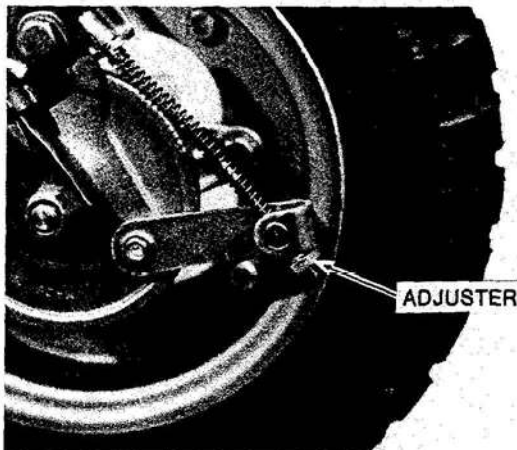

- Loosen the adjuster at the hand lever and turn it so that the slots align. Pull the cable housing out of the adjuster and then slip the cable through the slot. The cable end will fall out of the socket in the lever.

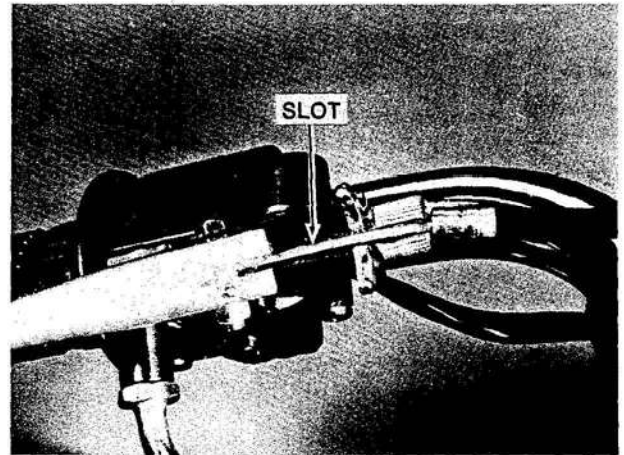

- Pull the cable free of the motorcycle.

Installation Notes:

- Lightly grease the cable end where it fits into the socket in the hand lever.
- Be sure the cable is routed so that it will not be pinched or abraded by the suspension or the frame during use.

Rear Brake Cable

Removal:

- Same as front brake cable. See p. 42.

Installation Notes:

- See installation notes for front brake cable (p. 42).
- Be sure to pass the cable through the guide on the rear fender.

LIGHTS

Headlight

Removal:

- Remove the screw from the bottom of the headlight housing.



- Lift the headlight rim off the housing. Pry the headlight clips loose, and remove the headlight lens unit.



- Use new lens unit clips if there are any doubts about the serviceability of the old ones. Be sure the lens fits into the ring as shown.

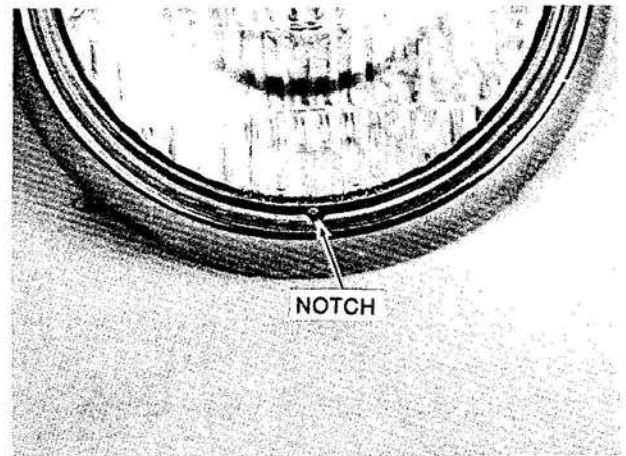

- Twist the bulb socket counterclockwise to remove it from the lens unit.

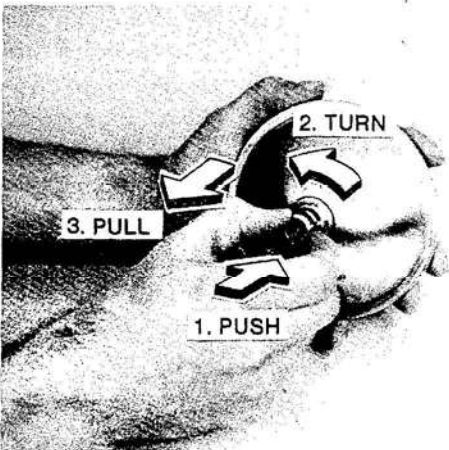

Tail Light Removal:

- Take out the two lens screws and pull the lens off with its gasket.

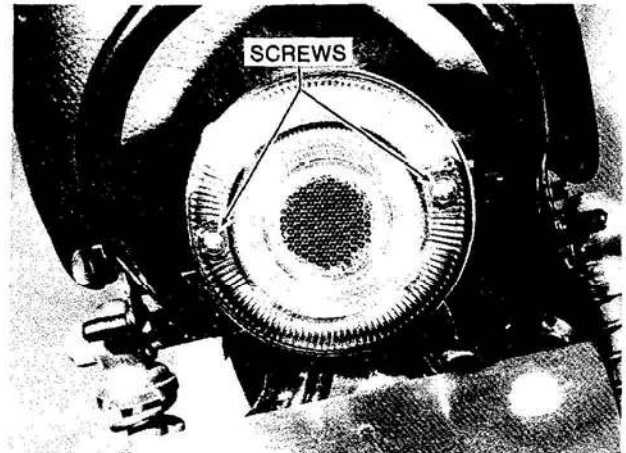

Installation Notes:

- Be sure the socket is clean and dry to assure good electrical contact. Align the bulb as shown.

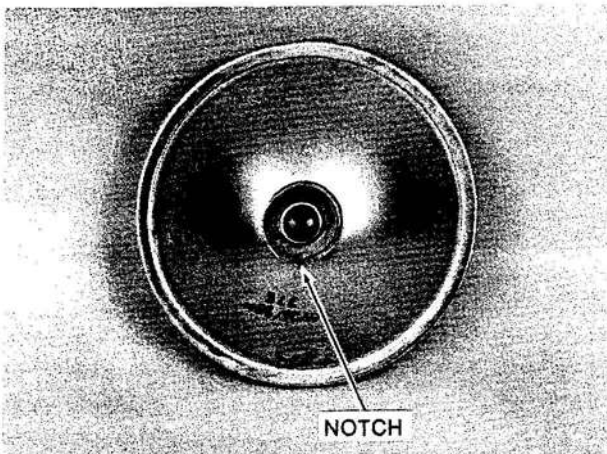

- To remove the bulb, push it into the socket, turn it counter clockwise, and pull it out.
- Three bolts with lockwashers hold the socket to the tail light bracket.

Installation Notes:

- Be sure the socket is clean and dry to assure good electrical contact.
- Only the red tail light wire connects to the main wiring harness.

44 DISASSEMBLY - CHASSIS

SWITCHES

Removal:

- Take out the handlebar switch case screws, and then separate the switch case halves.

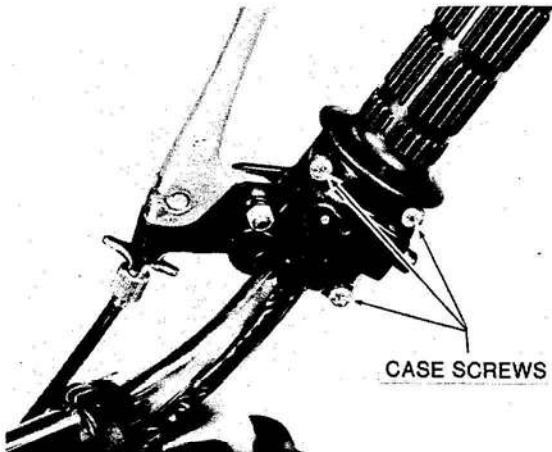

- Remove the wire holder tab screw in the case to take out the switches.

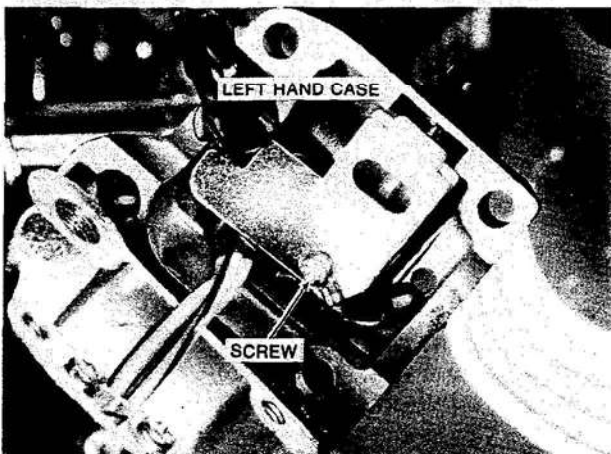
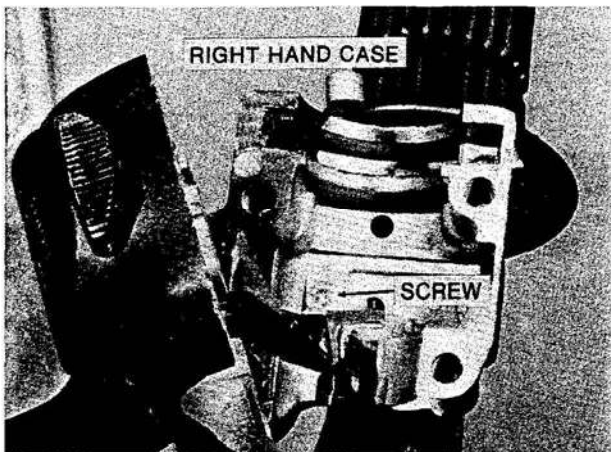

Installation Notes:

- Be sure the switch parts are clean and dry before installation to assure good electrical contact.

STEERING

Handlebars

Removal:

- Loosen the screws on the right hand switch case, and then slide the twist grip off the end of the handlebar.

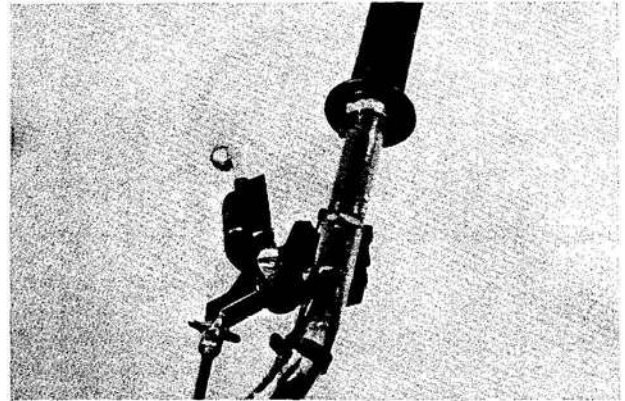

- Pull the left hand grip rubber off the handlebar.
- Remove the screws on the left hand switch case, and then take it off.

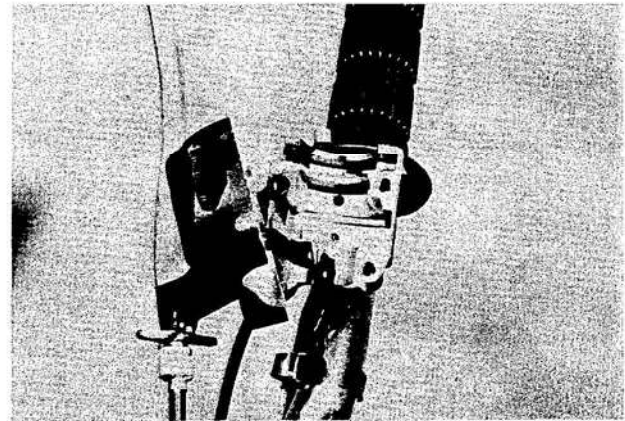

- Take off the handlebar knobs. Each has a spring inside it. Pull the handlebars out of the holders. Each handlebar holder is fastened to the forks with two bolts with lockwashers.

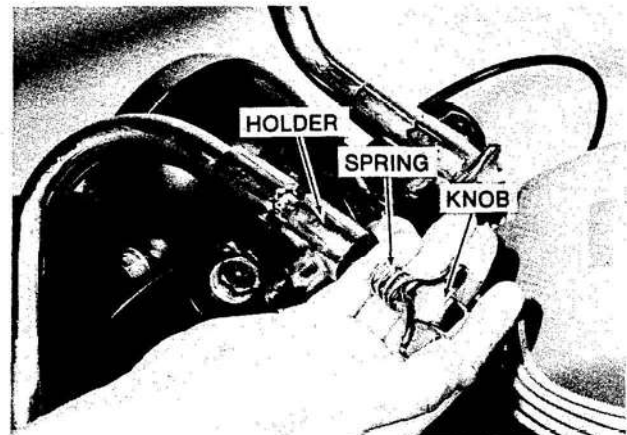

Installation Notes

- Be sure to tighten the handlebar holder bolts securely.
- Route the wiring to the handlebar switches so that it does not bind or stretch when the bars are folded down.

Steering Stem Bearings**Removal:**

- Remove the front forks (p. 45).
- Drive the bearings out with a long pin punch and a hammer.

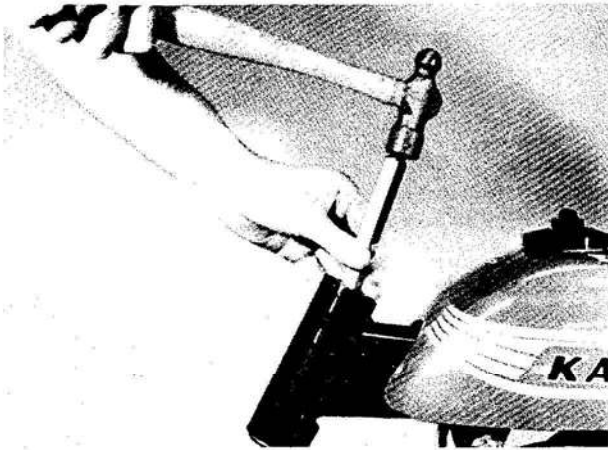
**Installation Notes:**

- Install the bearings with the concave side out. Be sure to put the support washers in behind each bearing.



- Adjust the steering stem bearings (p. 9).

SUSPENSION AND DRIVE CHAIN**Front Fork****Removal:**

- Remove the front wheel (p. 38).
- Remove the handlebars and holders (p. 44).
- Remove the headlight (p. 42) and headlight shell.
- Take out the bolts and remove the front fender.

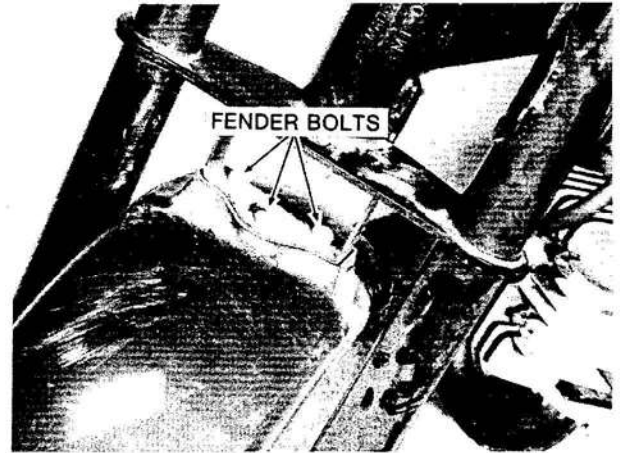

- Unscrew the steering stem nuts and pull the bolt out.

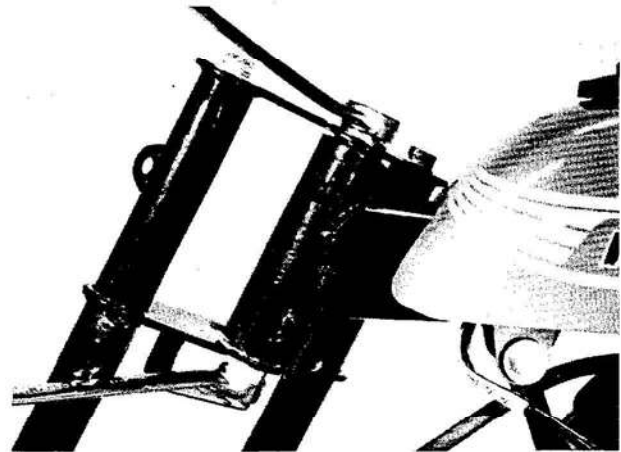

- Pull the forks off to the front.

Installation Notes:

- Put the steering stem bolt in from the top.
- Adjust the steering (p. 9).

46 DISASSEMBLY - CHASSIS

Rear Suspension

Removal:

- Remove the rear wheel (p. 39).
- Take out the bottom shock absorber bolts with their lockwashers. The top end of the shock absorbers are both held by one long bolt. Remove it to take off the shocks.

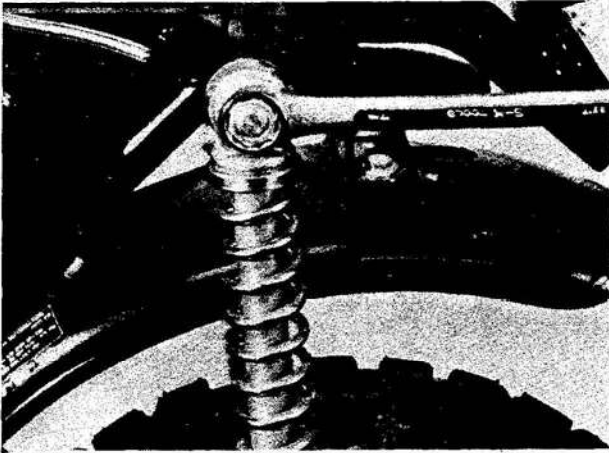

- Remove the swing arm pivot bolt, and then pull the swing arm off to the rear of the motorcycle.

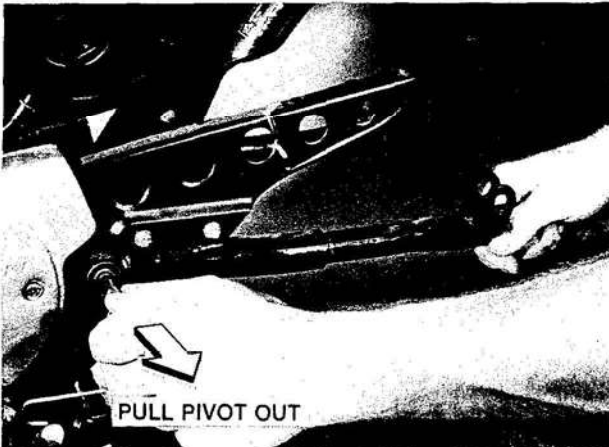

- The swing arm bushings can be removed by driving them out with a driver and a hammer.

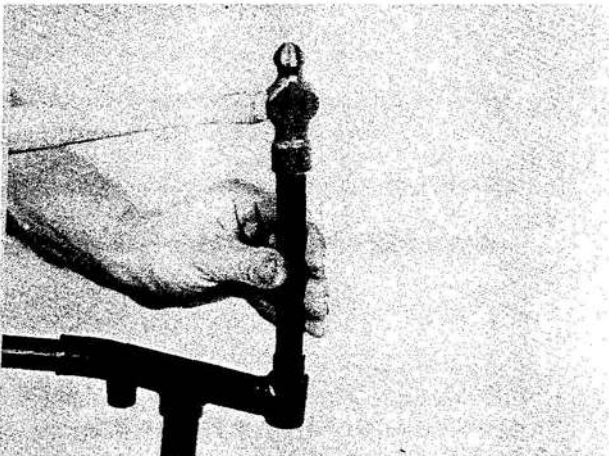

Installation Notes:

- Install the swing arm bushings with the same driver used for removal.
- Tighten the swing arm pivot bolt to 2.55 - 3.5 kg-m (18.4 - 25.3 lb-ft) of torque.
- Tighten the top and bottom shock absorber mount bolts to 4.5 - 6.2 kg-m (32.5 - 44.8 lb-ft) of torque.

Drive Chain

Removal:

- Take off the master link clip, and pull the master link out. The chain will fall off.

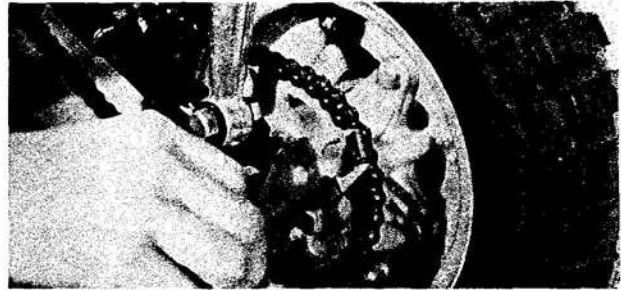

Installation Notes:

- Loosen the adjusters as far as they will go and kick the wheel forward before installing the chain.

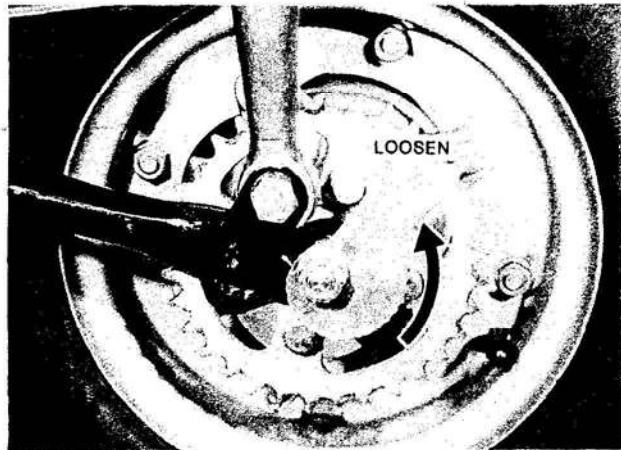

- Install the master link clip with the open end of the clip toward the rear with respect to chain travel.

Master Link Installation

Direction of Chain Rotation

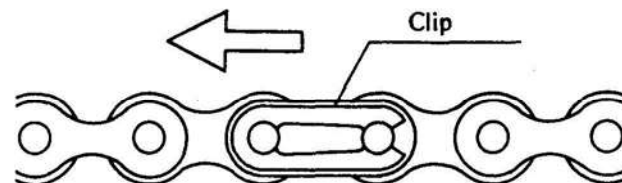

- Adjust the drive chain (p. 10).

MAINTENANCE

TABLE OF CONTENTS

Air Cleaner	48
Fuel Tank, Fuel Tap	48
Carburetor	48
Cylinder and Piston	49
Cylinder Head	54
Crankshaft	54
Clutch	56
Transmission	59
Kickstarter	62
Oil Pump	63
Engine Bearings, Bushings, and Oil Seals	64
Muffler	65
Tires	65
Wheels and Axles	66
Brakes	66
Drive Chain	68
Sprockets	69
Steering Stem	70
Front Forks	70
Rear Suspension	71
Ignition System	72
Lighting System	75

AIR CLEANER

The air cleaner removes dust and dirt from the air going to the engine. If the air cleaner becomes clogged so that it cannot pass air freely, the engine will run too rich. If the air cleaner allows dirt to get into the engine, abnormal wear will result.

To clean the air cleaner, remove it, and then roll the foam element off the wire form. Rinse the element in a high flash point solvent to remove all dirt. Squeeze it dry and inspect it for holes and tears. Then soak the element in SAE 30W oil and squeeze it as dry as possible. Install the element, being careful not to tear it. Brush any dirt out of the air cleaner housing and lightly oil the felt lining.

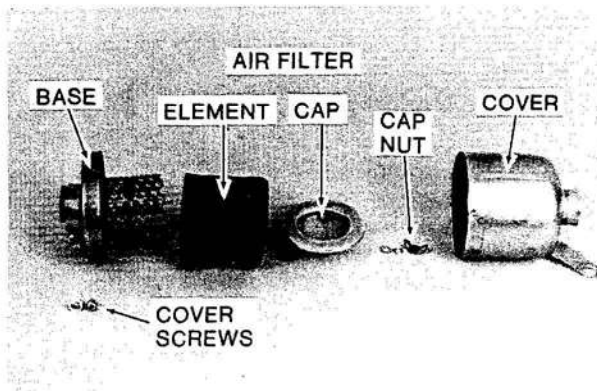

FUEL TANK, FUEL TAP

The fuel tank capacity is 3.0 liters (0.8 U.S. gallons). A cap is attached to the top; a fuel tap, to the bottom. The vent on the cap can be closed for transporting the motorcycle, and opened during use to prevent low pressure (partial vacuum) in the tank from hindering fuel flow.

The fuel tap has three positions: when the handle is horizontal, no fuel will flow; when the handle is down, fuel flows.

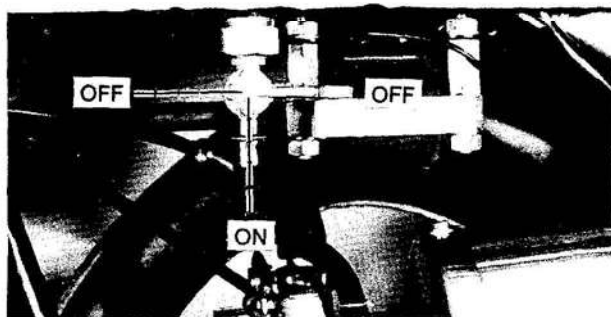

Carburetor cifications Table

Type	Main Jet	Needle Jet	Jet Needle	Pilot Jet	Throttle Valve Cutaway	Air Jet	Air Screw	Fuel Level
VM15SC	70R	E-0	3G9-3rd*	15	2.0	0.5	1 1/2 Turns	4-6mm

*The "9" of 3G9-3rd shows lot number, and may vary. The "3rd" is the groove number for the clip.

The fuel tap has a nylon strainer on the inlet tube to prevent dirt or debris from entering the carburetor.

Inspection and Cleaning

If fuel leaks from the cap or from around the fuel tap, then the cap, the tap gasket, or the tap O-ring may be damaged. Visually inspect these parts and replace if necessary.

Examine the air vent in the cap to see if it is obstructed. Use compressed air to remove any obstruction. The cap vent must be turned to the "ON" position or it will not pass air.

To clean out the fuel tank, disconnect the fuel hose, remove the fuel tap, and flush out the tank with a high flash point solvent. If the tank needs cleaning, check the carburetor float bowl as well. It may be cleaned by removing the four screws to take off the bowl. Drain the fuel and clean out any sediment.

CARBURETOR

The carburetor is a Mikuni VM15SC. Its job is to mix the air and fuel going to the engine in the proper proportions for good running under all loads at all engine speeds. It does this with four basic systems: the starter system, the pilot system, the main system, and the float system. The starter system consists of a valve which can be opened to allow an extra rich mixture to be drawn through the starter jet into the engine for starting the engine when it is cold. The pilot system is an easily adjustable lower-speed fuel and air supply system; it meters the fuel needed

Jet Needle

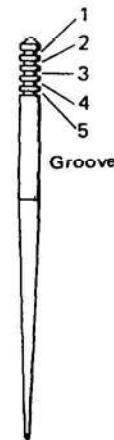

by the engine at idle and during low speed operation. The main system consists of the main jet through which fuel is drawn, to be metered at less than wide-open throttle by the jet needle and needle jet, and finally admitted to the carburetor throat to pass into the engine. The main system supplies fuel for moderate and high speed (or high power) operation. The float system controls the amount of fuel allowed into the fuel bowl. The other systems draw all their fuel from the fuel bowl, and depend on the float system to keep the right quantity of fuel in the bowl.

Fuel Level Measurement and Adjustment

Pull the fuel bowl drain hose off the drain outlet and push a piece of clean, clear plastic tubing over the outlet. Hold the end of the tube up near the side of the carburetor at about where the slide is. With the motorcycle held vertical, turn on the fuel tap and push the drain button. Note the distance from the level of the fuel in the tube (when it stops rising) to the flange of the carburetor mixing chamber. The distance should be 4 to 6mm.

Fuel Level Measurement

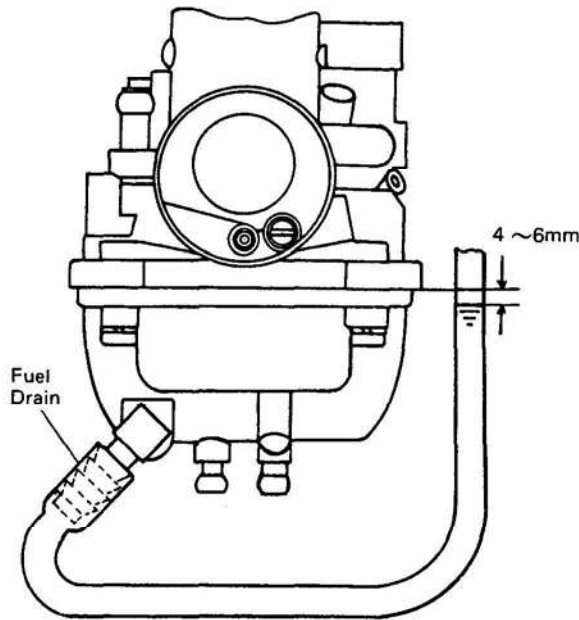

If the fuel level is incorrect, remove the float bowl and the float. Bend the tab on the float to change the fuel level.

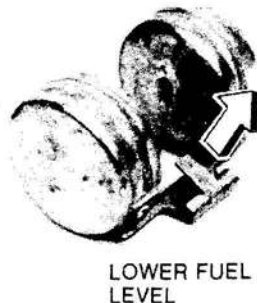

Carburetor Cleaning and Inspection

Dirt or other foreign material in the carburetor's small fuel and air passages will cause it to malfunction. Different parts of the carburetor control the fuel/air mixture at different throttle openings. The following are the main parts affecting each throttle opening range:

0 to 1/8 throttle	pilot system (air screw)
1/8 to 1/4 throttle	throttle valve (cutaway)
1/4 to 3/4 throttle	jet needle (position)
3/4 to full throttle	main jet (size)

(The items in parentheses are the adjustments for each item). By noting the throttle range in which a carburetion problem occurs, the offending system or part may be pinpointed.

To clean any part of the carburetor, remove and completely disassemble the carburetor. Wash all metal parts in carburetor cleaner.

CAUTION Rubber and plastic parts may be attacked by carburetor cleaner. Blow out all air and fuel passages with compressed air. Check all parts for excessive wear or damage. The slide should fit easily in the mixing chamber, but if it rattles around, it must be replaced. If the float valve needle tip is worn even a little, replace it. If the jet needle is excessively worn, it must be replaced; but a shiny spot is normal. The float must not be dented or show signs of leakage. The rubber tip on the starter system valve and the O-ring on the fuel bowl drain valve must not be hardened or torn, or they will leak. Finally, be sure the phenolic bushing in the carburetor clamp area is in good condition, and that the fuel bowl gasket does not leak.

CYLINDER AND PISTON

The cylinder, being part of the combustion chamber, is subjected to extremely high temperatures. Since excessive heat can seriously distort the shape of the cylinder or cause piston seizure, the outside of the cylinder is finned to increase the heat radiating surface for better cooling efficiency. To minimize distortion from heat and to maximize durability, the cylinder is made of special cast iron.

The piston is made from an aluminum alloy, which expands and distorts slightly from heat during engine operation. So that the piston will become cylindrical after heat expansion, it is designed such that, when cold, it is tapered in towards the head and is elliptical rather than perfectly round. The piston diameter is made so that there is enough clearance between the piston and cylinder to allow for expansion. Two rings are fitted into grooves near the top of the piston so that gas does not escape between the piston and the cylinder wall into the crank chamber.

50 MAINTENANCE - CYLINDER AND PISTON

The full floating type of piston pin is used to connect the piston to the con-rod. The middle part of the piston pin passes through a caged needle bearing fitted into the small end of the con-rod, and a snap ring is fitted at each end of the piston pin in a groove to prevent the pin from coming out. Since the pin is the full floating type, a small amount of clearance exists between the piston pin and the piston when the engine is at normal operating temperatures.

Proper inspection and maintenance of the cylinder and piston include checking the compression; removing carbon from the piston head, piston ring grooves, and cylinder exhaust port; and checking for wear and proper clearance during top end overhaul. Heavy carbon deposits in the combustion chamber raise compression, which results in overheating, detonation, and preignition. A worn cylinder, worn piston, or worn or stuck piston rings cause a loss of compression from gas blowby past the rings since the rings will not form a satisfactory seal between the piston and cylinder wall during compression. This gas blowby will result in difficult starting, power loss, excessive fuel consumption, and possibly engine destruction. A worn piston pin causes piston slap, which will result in accelerated piston and cylinder wear.

Engine problems may be caused not only by carbon deposits and wear or damage to the engine itself, but also by poor quality fuel or oil, improper oil, improper fuel/air mixture, improper supply of oil, or incorrect ignition timing. Whenever knocking, pinging, piston slap, or other abnormal engine noise is heard, the cause should be determined as soon as possible. Neglect of proper maintenance will result in reduced engine power and may lead to accelerated wear, overheating, detonation, piston seizure, and engine destruction.

Compression Measurement

A compression test is very useful as an aid in determining the condition of the engine. Low compression may be due to cylinder wear; worn piston ring grooves; worn, broken, or sticking piston rings; cylinder head leaks; or damage to the engine such as piston seizure. Too high a compression may be due to carbon build-up on the piston head and cylinder head.

Before measuring compression, check that the cylinder head is tightened down to 0.6 - 0.9 kg-m (4.5 - 6.5 lb-ft) of torque, and then thoroughly warm up the engine so that engine oil between the piston and cylinder wall will help seal compression as it does during normal running. While the engine is running, check that there is no gas leakage from around the spark plug or the cylinder head gasket.

Stop the engine, remove the spark plug, and screw the compression gauge hose securely into the spark plug hole so that there will be no leakage. With the throttle fully open so that air can flow freely to the engine, turn the engine over by the kick starter until the compression gauge stops rising. The compression is the highest reading obtainable.



Cylinder Compression

Standard	Service Limit
10.4 kg/cm ² (148 psi)	7.3 kg/cm ² (104 psi)

Cylinder, Piston Decarbonization

Carbon readily accumulates around the cylinder exhaust port, which reduces exhaust efficiency. To remove the carbon, take off the cylinder (p. 18), and scrape the carbon out of the exhaust port carefully. At this time, the muffler should also be inspected, and cleaned if necessary (p. 65).



Built-up carbon on the piston head reduces the cooling ability of the piston and raises compression, leading to overheating which could possibly even melt the top of the piston. To decarbonize the piston head, remove the piston (p. 19), scrape off the carbon, and then lightly polish the piston with fine emery cloth.

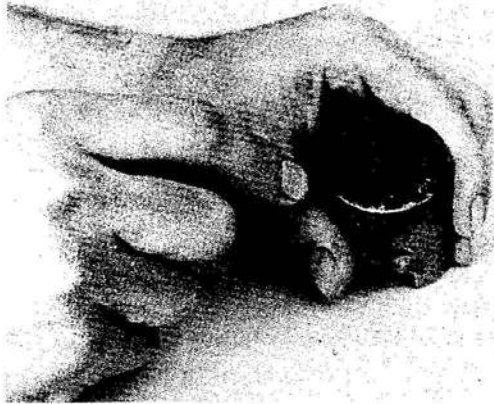

Carbon, accumulated in the piston ring grooves, can cause the rings to stick. Remove the ring (p. 19), and clean out any carbon deposits using the end of a broken piston ring or some other suitable tool.



CAUTION When removing carbon, take care not to scratch the cylinder wall or the side of the piston. Never clean the piston head with the engine assembled. If the carbon is scraped from the piston head with the cylinder left in place, carbon particles will unavoidably drop between the piston and cylinder onto the rings and eventually find their way into the crank chamber. Carbon particles, which are very abrasive, drastically shorten the life of the rings, piston, cylinder, crankshaft bearings, and oil seals.

Cylinder, Piston Wear

Since there is a difference in cylinder wear in different directions, take a side to side and a front to back measurement at each of the 3 locations (total of 6 measurements) shown in the illustration. If any of the cylinder inside diameter measurements exceeds the service limit, or if there is a difference of more than 0.05mm (0.002 in.) between any two measurements, the cylinder will have to be bored to oversize and then honed. However, if the amount of boring necessary would make the inside diameter greater than 45.8mm, the cylinder must be replaced.

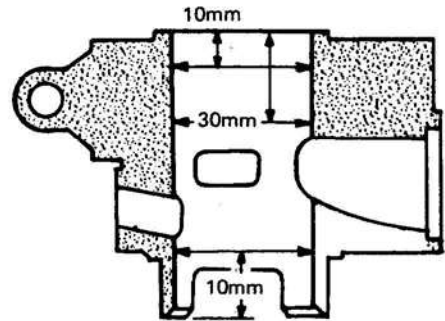

Cylinder Inside Diameter

Standard	Service Limit
46.000 - 46.016mm and less than 0.01 mm difference between any two measurements	46.100mm, or more than 0.05mm difference between any two measurements

Measure the outside diameter of the piston 5mm (0.2 in.) up from the bottom of the piston at a right angle to the direction of the piston pin. If the measurement is under the service limit, replace the piston.

NOTE: Abnormal wear such as a marked diagonal pattern across the piston skirt may mean a bent con-rod or a misaligned crankshaft.

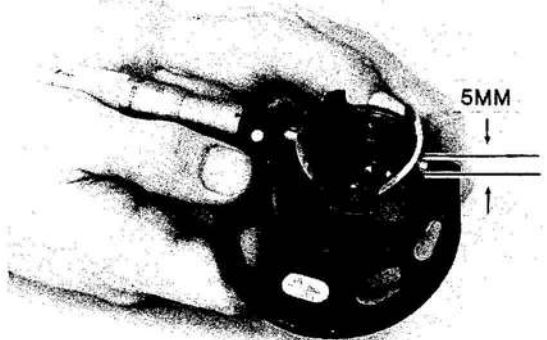

Piston Diameter

Standard	Service Limit
45.964 - 45.984mm	45.80mm

These tables apply only to the standard sized cylinder of the cylinder over the rings, pressing in on opposite sides as necessary. Be certain the rings do not slip out of the proper t the cylinder was bored to plus 0.1mm, and the service limit for the piston is the oversize piston original diameter minus 0.14mm. If the exact figure is unknown, it can be determined roughly by measuring the diameter at the base of the cylinder.

NOTE: Whenever the piston or cylinder has been replaced with a new one, the motorcycle must be broken in the same as with a new machine.

Piston/Cylinder Clearance

The piston to cylinder clearance is measured whenever the piston or cylinder is replaced with a new one, or whenever the cylinder is rebored and an oversize piston installed. The standard piston to cylinder clearance must be adhered to whenever the cylinder is replaced or rebored. However, if only the piston is replaced, the clearance may exceed the standard slightly, but it must not be less than the minimum in order to avoid piston seizure.

The most accurate way to find the piston clearance is by making separate piston and cylinder diameter measurements and then computing the difference between the two values. Measure the piston diameter as just described, and measure the cylinder diameter at the very bottom of the cylinder.

Piston/Cylinder Clearance

Standard
0.034 - 0.040mm

Boring, Honing

When boring and honing the cylinder, note the following:

1. Before boring the cylinder, first measure the exact diameter of the oversize piston, and then, in accordance with the standard clearance given above, determine the diameter of the rebore.
2. Cylinder inside diameter must not vary more than 0.01mm at any point.
3. There are two sizes of oversize pistons available: 0.5mm and 1.0mm.
4. Be wary of measurements taken immediately after boring since the heat affects cylinder diameter.

Piston/Cylinder Seizure

Remove the cylinder and piston to check the damage. If there is only slight damage, the piston may be smoothed with No. 400 emery cloth, and any aluminum deposits removed from the cylinder with either No. 400 emery cloth or light honing. However, in most cases, the cylinder will have to be bored to oversize and honed, and an oversize piston installed.

Piston Ring, Piston Ring Groove Wear

Visually inspect the piston rings and the piston ring grooves. If the rings are worn unevenly or damaged, they must be replaced. If the piston ring grooves are worn unevenly or damaged, the piston must be replaced and fitted with new rings.

With the piston rings in their grooves, make several measurements with a thickness gauge to determine piston ring/groove clearance. If the clearance exceeds the service limit, measure the thickness of the piston rings and the width of the ring grooves. If the ring has worn down to less than the service limit, replace the ring; if the groove width exceeds the service limit, replace the piston.

**Piston Ring/Groove Clearance**

	Standard	Service Limit
Top Ring	0.09 - 0.12mm	0.23mm
Bottom Ring	0.05 - 0.09mm	0.19mm

Piston Ring Thickness

	Standard	Service Limit
Both Rings	1.97 - 1.99mm	1.90mm

Piston Ring Groove Width

	Standard	Service Limit
Top Ring	2.08 - 2.10mm	2.18mm
Bottom Ring	2.04 - 2.06mm	2.14mm

When new rings are being fitted to a used piston, check for uneven groove wear by inspecting the ring seating. The rings should fit perfectly parallel to the groove surfaces. If not, the piston must be replaced.

Piston Ring End Gap

Place the piston ring inside a new cylinder, or if a new cylinder is not available, inside a cylinder as little worn as possible, using the piston to locate the ring squarely in place. If it is placed in a used cylinder, set it close to the bottom of the cylinder, where cylinder wear is low. Measure the gap between the ends of the ring with a thickness gauge. If the gap is wider than the service limit, the ring is overworn and must be replaced.

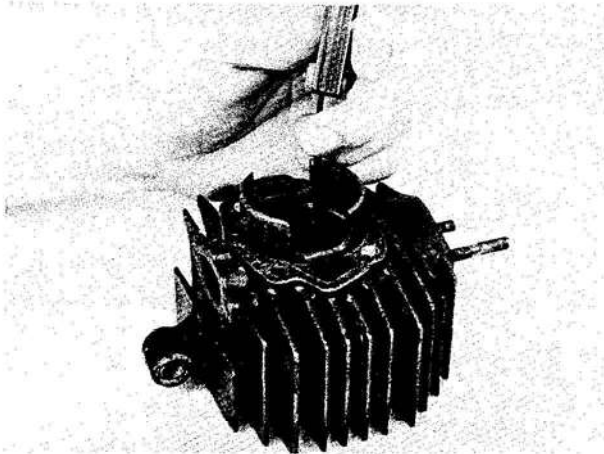

Piston Ring End Gap

Standard	Service Limit
0.015-0.35mm	0.65mm

Piston Ring Tension

Piston ring tension can be evaluated by measuring the gap between the ends of the ring with the ring free of any restraint. If the measured gap is less than the service limit, the ring is weak and must be replaced.

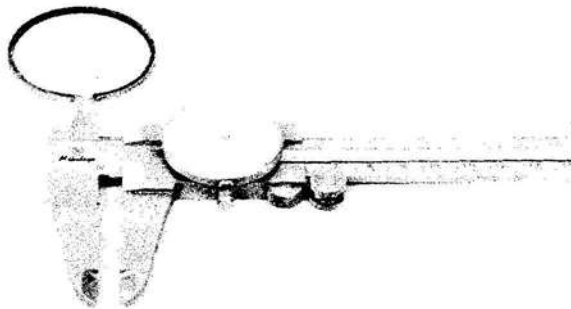

Piston Ring Free Gap

	Standard	Service Limit
Top Ring	5.6mm	4.9mm
Bottom Ring	7.3mm	6.6mm

Piston, Piston Pin, Con-rod, Needle Bearing Wear

Measure the diameter of the piston pin with a micrometer, and measure the inside diameter of both piston pin holes in the piston. If the piston pin diameter is less than the service limit at any point, replace the piston pin. If either piston pin hole diameter exceeds the service limit, replace the piston.

Measure the inside diameter of the con-rod small end. If the diameter exceeds the service limit, replace the con-rod.

The rollers in the needle bearing wear so little that the wear is difficult to measure. Instead, inspect the needle bearing for abrasions, color change, or other damage. If there is any doubt as to its condition, replace the needle bearing.

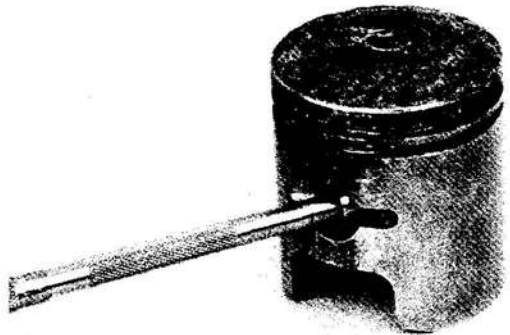

Piston Pin, Piston Pin Hole, Small End Diameter

	Standard	Service Limit
Piston Pin	11.994 - 12.000mm	11.960mm
Piston Pin Hole	12.000 - 12.008mm	12.080mm
Small End Dia	16.003 - 16.014mm	16.050mm

TO THE DEALER: When possible, match parts from stock so that a marked pin is assembled with an "A" piston and an unmarked pin with a "B" piston.

NOTE: When a new piston or pin is used, check that piston to pin clearance is 0.002 - 0.008mm.

CYLINDER HEAD

The cylinder head is made of aluminum alloy, used for its high heat conductivity, and is finned on the outside to aid heat radiation. If carbon builds up inside the combustion chamber, however, cooling efficiency is reduced and preignition, detonation, and overheating may result. Trouble may also come from improper head mounting or mounting torque, causing compression leakage.

Cleaning and Inspection

Remove the cylinder head (p. 18). Scrape out any carbon, and clean the head with gasoline.

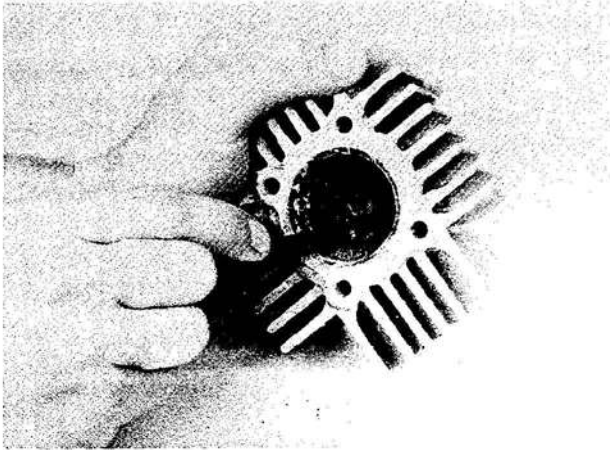

Check the cylinder head gasket surface for warp or other damage by rubbing it on a surface plate coated with machinist's bluing. Repair light damage by rubbing the gasket surface on emery cloth (first No. 200, then No. 400) secured to the surface plate. After smoothing the cylinder head gasket surface, coat it with machinist's bluing, and rub it over the cylinder gasket surface; if necessary, repair the surface in the same manner that the cylinder head was repaired. Severe damage to either of the gasket surfaces necessitates replacement.

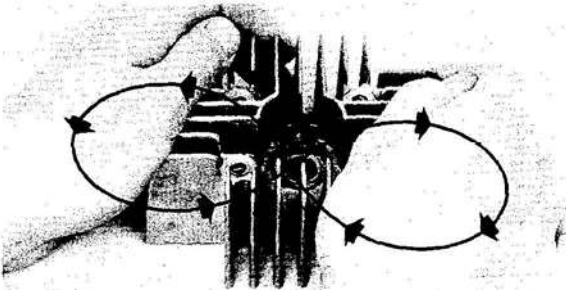

NOTE: Use only the proper gasket for the cylinder head use of a gasket of incorrect thickness will change the compression.

CRANKSHAFT

The crankshaft is the part that changes the reciprocating motion of the piston into rotating motion, which is transmitted to the rear wheel when the clutch is engaged. Crankshaft trouble, such as excessive play or runout, will multiply the stress caused by the intermittent force on the piston, and will result in not only rapid crankshaft bearing wear, but also noise, power loss, vibration, and shortened engine life. A defective crankshaft should always be detected at an early stage and then repaired immediately.

The following explanation concerns the most common crankshaft problems, the method for measuring warp, play, and runout, and the method for correcting flywheel misalignment. Since the crankshaft assembly requires a hydraulic press and special tools to attain the precise tolerances that are required, a defective crankshaft should be either rebuilt by a properly equipped shop or replaced as an assembly.

Connecting Rod Bending, Twisting

Set the crankshaft in a flywheel alignment jig or on V blocks on a surface plate. Select an arbor of the same diameter as the piston pin and of optional length, and insert it through the small end of the connecting rod.

Using a height gauge or dial gauge, measure the difference in the height of the rod above the surface plate over a 100mm (4 in.) length to determine the amount the connecting rod is bent.

Using the arrangement shown in the illustration, measure the amount that the arbor varies from being parallel with the crankshaft over a 100mm (4 in.) length of the arbor to determine the amount the connecting rod is twisted.

CONNECTING ROD BEND

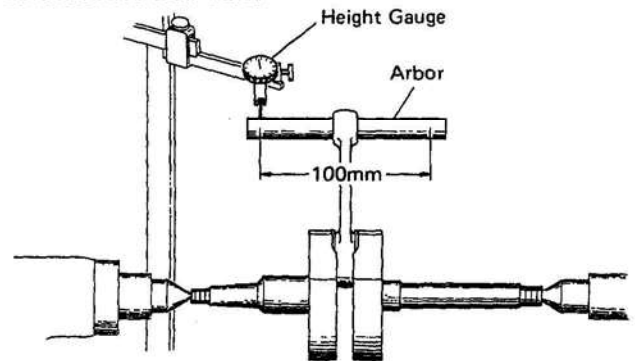

CONNECTING ROD TWIST

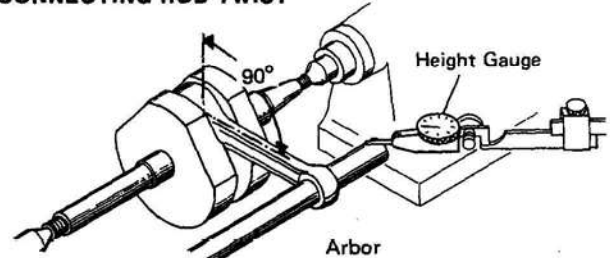

Connecting Rod Bend and Twist

Standard	Service Limit
under 0.05mm/ 100mm	0.20mm

If either of the above measurements exceeds the service limit, the connecting rod or the crankshaft assembly must be replaced.

Connecting Rod Big End Radial Clearance

Set the crankshaft in a flywheel alignment jig or on V blocks, and place a dial gauge against the big end of the connecting rod. Push the connecting rod first towards the gauge and then in the opposite direction. The difference between the two gauge readings is the radial clearance.

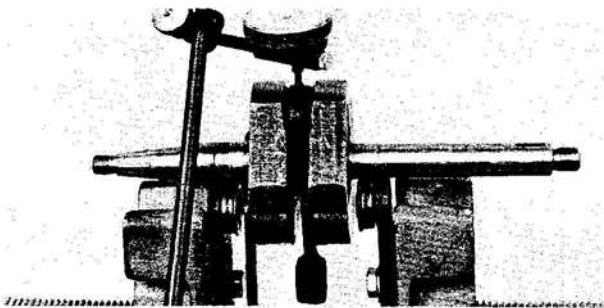

If the radial clearance exceeds the service limit, the crankshaft should be either replaced or disassembled and crankpin, needle bearing, and connecting rod big end examined for wear.

Connecting Rod Radial Clearance

Standard	Service Limit
0.007 - 0.020mm	0.070mm

Connecting Rod Side Clearance

Measure the side clearance of the connecting rod with a thickness gauge as shown in the figure. If the measured value exceeds the service limit, the crankshaft should be either replaced or disassembled and the side washers examined for wear.

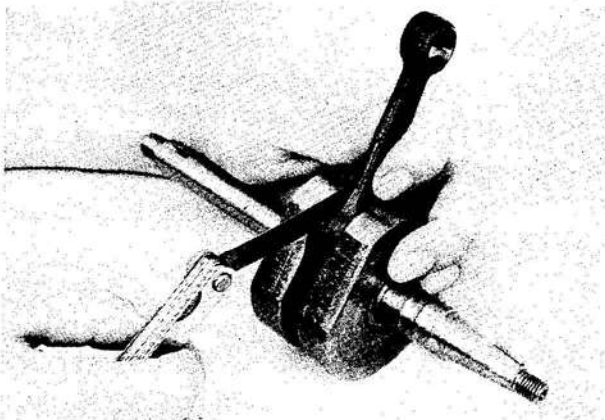

Connecting Rod Big End Side Clearance

Standard	Service Limit
0.25 - 0.30mm	0.50mm

Crankshaft Runout

Set the crankshaft in a flywheel alignment jig, and place a dial gauge to the points indicated. Turn the crankshaft slowly. The maximum difference in gauge readings is the crankshaft runout.

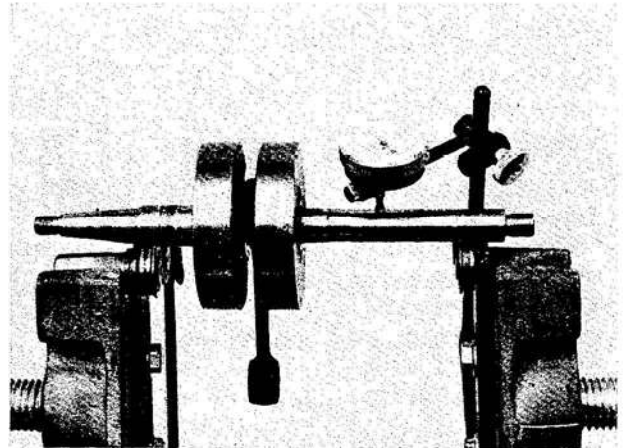

If the runout at either point exceeds the standard limit but at neither point exceeds the repair limit, the flywheels must be aligned so that the runout falls within the standard limit. As shown in the illustrations, there are three types of flywheel misalignment. In the case of horizontal misalignment, which is the most common, strike the projecting rim of the flywheel with a plastic, soft lead, or brass hammer as indicated in the figure. Recheck the runout with a dial gauge, repeating the process until the runout falls within the standard limit. Vertical misalignment is corrected either by driving a wedge in between the flywheels or by squeezing the flywheel rims in a vice, depending on the nature of the misalignment. In case of both horizontal and vertical misalignment, correct the horizontal misalignment first.

56 MAINTENANCE - CLUTCH

Flywheel Horizontal Misalignment

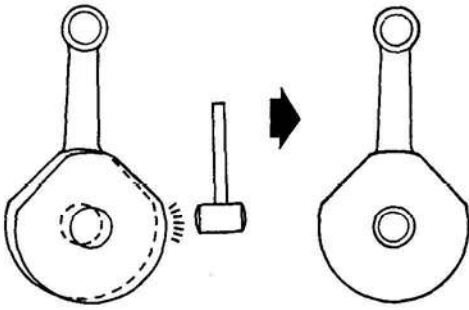

Flywheel Vertical Misalignment

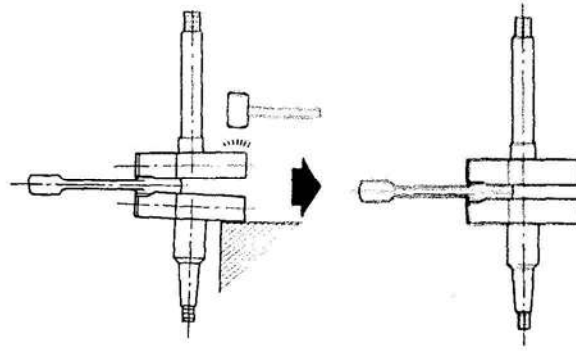

Crankshaft Runout

Standard	Service Limit
under 0.03mm	0.09mm

Big End Seizure

In case of serious seizure with damaged flywheels, the crankshaft must be replaced. In case of less serious damage, disassemble the crankshaft and replace the crankpin, needle bearing, side washers, and connecting rod.

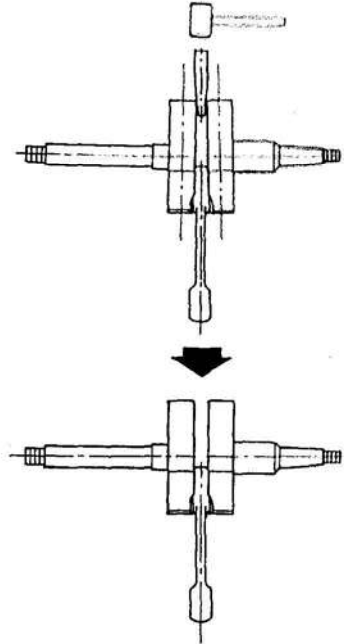

CLUTCH

The clutch is a centrifugal-type, automatic clutch. At idle speed the clutch is disengaged. As engine speed increases, a set of balls inside the clutch are forced outward by centrifugal force. As the balls move away from the center of the clutch, they wedge the clutch plates together, and power is transmitted from the engine to the gear box.

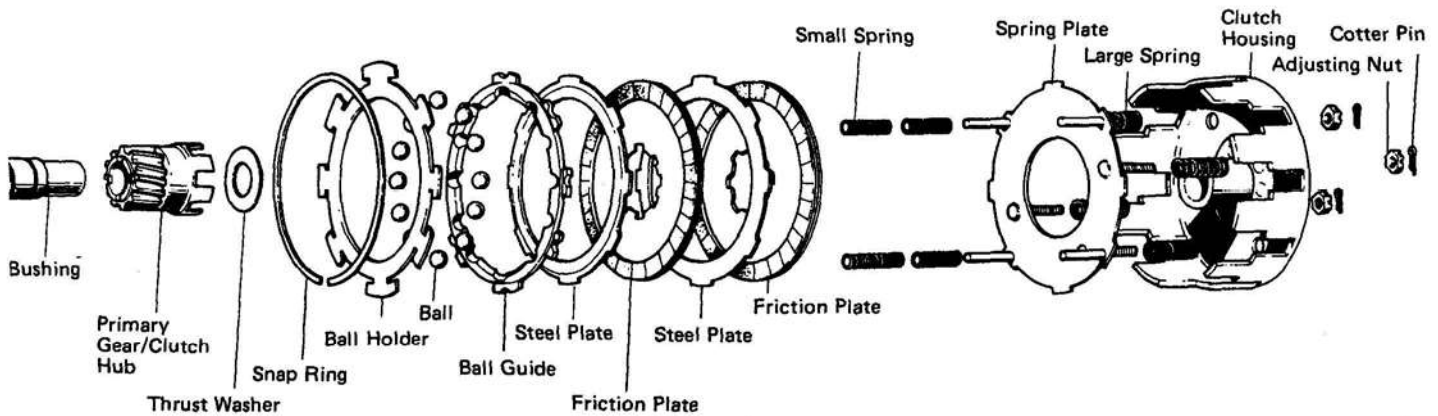

In the first illustration, the clutch is disengaged. Note the relative position of the balls, and the space between the steel and friction plates. In the second illustration, the clutch has engaged. The balls have moved farther from the center of the clutch, riding up the ramps in the ball guide, forcing the steel and friction plates into contact with each other. The small springs insure proper disengagement at low engine speeds, by forcing the first and last steel plates apart. The large springs cushion the engagement and allow the clutch to be adjusted to compensate for friction plate wear by turning the adjuster nuts.

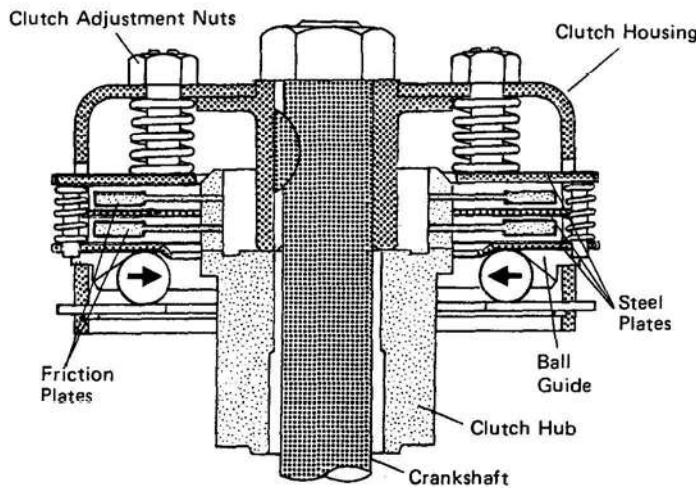

DISENGAGED

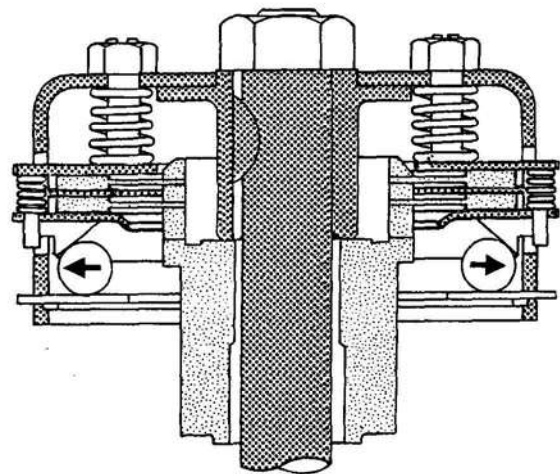

ENGAGED

Power flow through the clutch is from the crankshaft to the clutch housing, to the steel plates, to the friction plates, to the hub (which has the primary drive pinion built into it), to the input shaft gear, and into the transmission.

A clutch that does not disengage properly will cause the motorcycle to "creep" at an idle when it is in gear. On the other hand, a clutch that slips excessively, will reduce power transmission efficiency and may overheat and burn out. A clutch that does not disengage properly may be caused by:

1. Clutch plates that are warped or too rough.
2. Adjuster nuts that are too loose.
3. Deteriorated transmission oil.
4. Transmission oil of too high a viscosity.
5. The clutch hub is frozen to the bushing.
6. An unevenly worn clutch hub or housing.
7. Missing parts.

A slipping clutch may be caused by:

1. Worn friction plates.
2. Adjuster nuts that are too tight.
3. Weakened large clutch springs.
4. An unevenly worn clutch hub or housing.

Clutch noise may be caused by:

1. Too much backlash in the primary drive gears.

2. Damaged primary drive gear teeth.
3. Too much clearance between the friction plate tangs and the clutch hub.
4. Too much clearance between the steel plate tangs and the clutch housing.
5. Deteriorated damper rubbers in the input shaft drive gear.
6. Metal chips jammed into the primary drive gears.

Clutch Spring Tension.

If the large clutch springs have lost tension, the clutch will not engage properly, and may slip even at high engine speeds. To check spring tension, measure their length at rest and compare it to the specification. If they are too short, replace them.

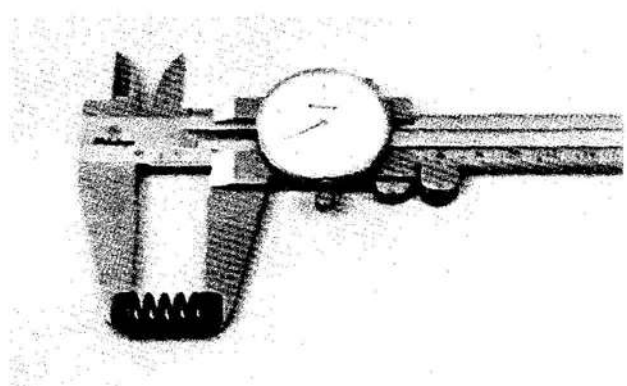

Clutch Spring Tension

	Standard Length	Service Limit
Large Spring	18.7mm	18.1mm
Small Spring	12.2mm	11.8mm

58 MAINTENANCE - CLUTCH

Friction Plate Wear, Damage

Visually inspect the friction plates to see whether or not they show any signs of heat seizure or have become rough or unevenly worn. Measure the thickness of the plates with vernier calipers.

If any plates show signs of damage, or if they have worn past the service limit, replace them for new ones.

Friction Plate Measurement

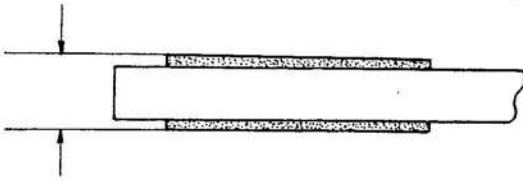

Friction Plate Thickness

Standard	Service Limit
2.75 - 3.05mm	2.65mm

Clutch Plate Warp

Place each friction plate and each steel plate on a surface plate, and measure the gap between each clutch plate and the surface plate. This gap is the amount of clutch plate warp. Replace any plates warped over the service limit.

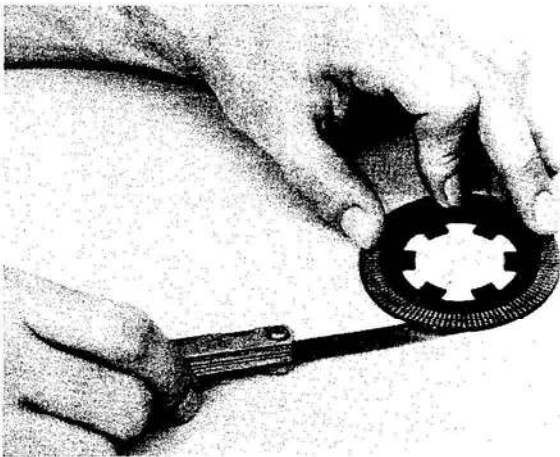

Clutch Plate Warp

Standard	Service Limit
under 0.1 mm	0.25mm

Friction Plate/Clutch Hub Clearance

Measure the clearance between the tangs on the friction plates and the fingers of the clutch hub. If this clearance is excessive, the clutch will be noisy.

If the clearance exceeds the service limit, replace the friction plates. Also, replace the clutch hub if it is unevenly or badly worn where the friction plates wear against it.

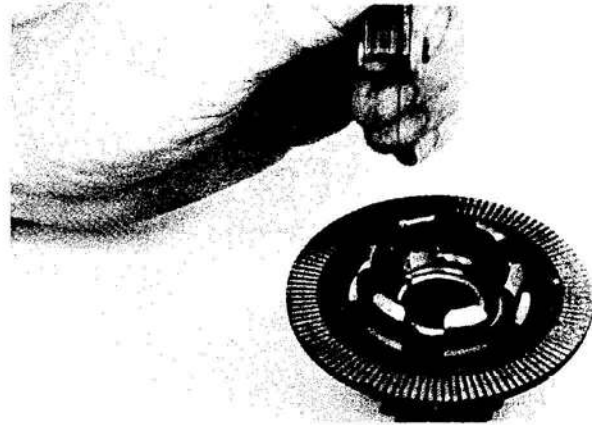

Friction Plate/Clutch Hub Clearance

Standard	Service Limit
0.09 - 0.40mm	0.65mm

Input Shaft Drive Gear Damage

Inspect the teeth on the input shaft drive gear. Any light damage can be corrected with an oilstone, but the gear must be replaced if the teeth are badly damaged. Damaged teeth on the input shaft drive gear indicate that the teeth on the primary gear, by which it is driven, may also be damaged. At the same time that the input shaft drive gear is repaired or replaced, the primary gear should be inspected, and then repaired or replaced if necessary. The primary gear is part of the clutch hub.

Primary Drive Backlash

Measure the backlash between the input shaft drive gear and primary gear with a dial gauge. Set the dial gauge against a tooth on the input shaft drive gear, and rotate the gear back and forth while keeping the primary gear stationary. The difference between the highest and lowest dial reading is the amount of backlash. If the amount of backlash exceeds the service limit, replace both the gears.

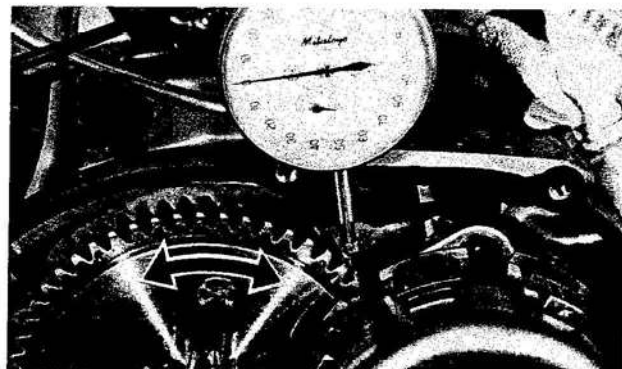

Primary Drive Backlash

Standard	Service Limit
0.06 - 0.22mm	0.27mm

Primary Gear/Bushing Clearance

Measure the diameter of the clutch bushing with a micrometer, and measure the inside of the primary gear with a dial bore gauge. Find the difference between the two readings to determine the clearance. Replace the bushing if the clearance exceeds the service limit.

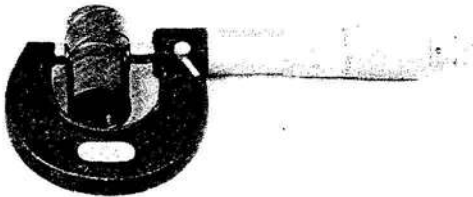

Primary Gear/Bushing Clearance

Standard	Service Limit
0.030 - 0.064mm	0.12mm

Clutch Housing Damage

Inspect the places where the tabs on the steel clutch plates contact the housing fingers. If there are notches worn in the housing fingers, replace the clutch housing.

TRANSMISSION

The transmission used in the MT1 and KV75 is a three-speed, return shift, constant mesh type. For simplicity, the drive shaft gears in the following explanation will be referred to as D1, D2, and D3 and the output shaft gears as O1, O2, and O3. The slider on the output shaft will be called OS.

D3, O1, and O2 turn freely on their shafts. D1 and O3 are actually a part of their shafts and, of course, they turn with their shafts at all times. D2 and OS are splined to their shafts, so that although they must turn with their shafts, they can slide sideways along them. In first gear, OS moves toward the right side of the engine to engage the dogs on O1. O1 must now turn with the output shaft, and because it meshes with D1 the power flow through the transmission is from the drive shaft, to D1, to O1, to OS, to the output shaft. In second gear, the slider moves to the left to engage O2. Now the power flow is from the drive shaft, to D2 (through the splines), to O2, to

OS, to the output shaft. In third gear, OS returns to a point half way between O1 and O2 engaging neither, D2 slides to the left to engage D3; and the power flow is from the drive shaft to D2, to D3, to O3, which is part of the output shaft. In neutral, neither D2 nor OS engages any gear; all the gears spin freely with no power transmitted between the shafts.

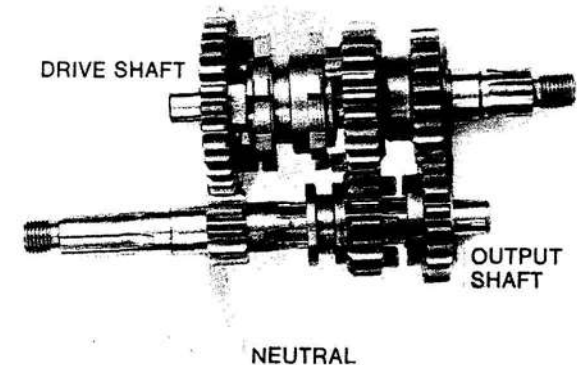
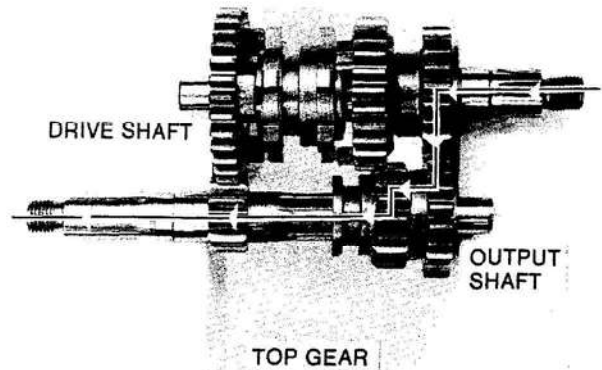
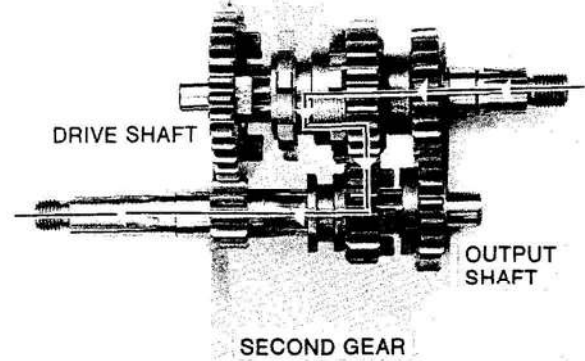
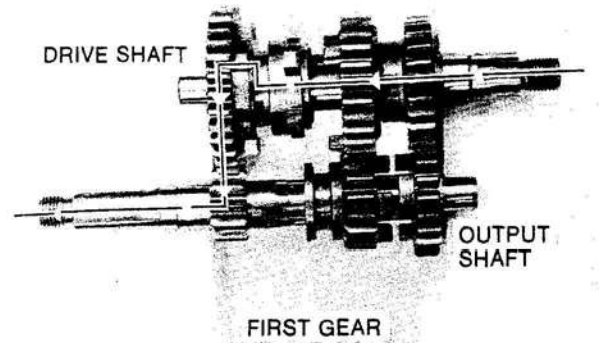

With the 1975 model, the transmission shift pattern was changed. On 1972 through 1974 models, the shift pedal is pushed down from neutral to engage 1st, 2nd, and 3rd successively. On 1975 and later models, the shift pedal is pushed down for 1st, then lifted for 2nd and 3rd. Neutral is half way between 1st and 2nd in the later version. To change the shift pattern, a new shift drum was incorporated, along with a new drum detent system using a spring-loaded plunger in a bore in the bottom of the right hand crankcase half. This required a new crankcase assembly as well.

External Shift Mechanism Inspection

Inspect the shift lever return spring, the shift lever ratchet spring, the shift lever parts, the shift drum detent levers, and the detent spring. Remove and inspect the neutral detent plunger and spring on 1975 and later models. Replace any broken or otherwise damaged parts. Check that the return spring pin and drum positioning plate are not loose. If either is loose tighten the locknut or screw.

Measure the free length of the shift ratchet mechanism spring. If it is longer than the service limit, replace it.

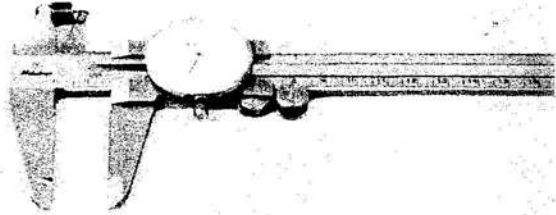

Shift Ratchet Spring Length

Standard	Service Limit
17.5 - 18.5mm	17mm

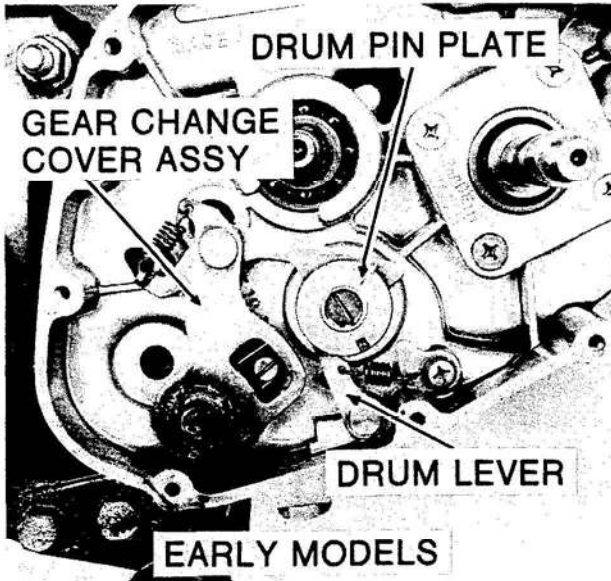

Shift Forks

Visually inspect the shift forks, and replace any shift fork that is bent or burned (discolored). If the motorcycle has experienced shifting problems, the shift forks may be at fault. Compare the forks with the photographs. The new, more desirable shift forks have more bearing surface where they bear on the transmission gear (or slider). The first and second gear shift fork has more area where it bears on the drum.

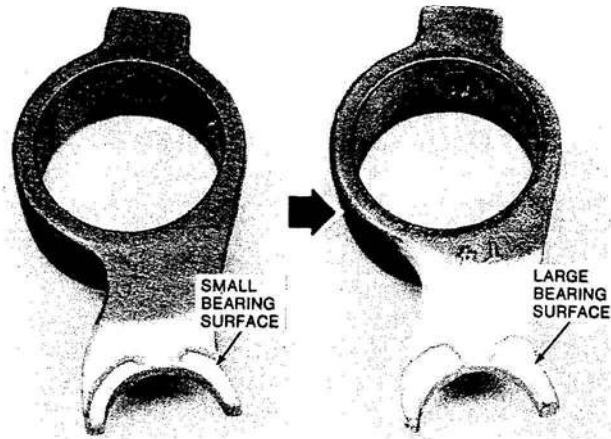

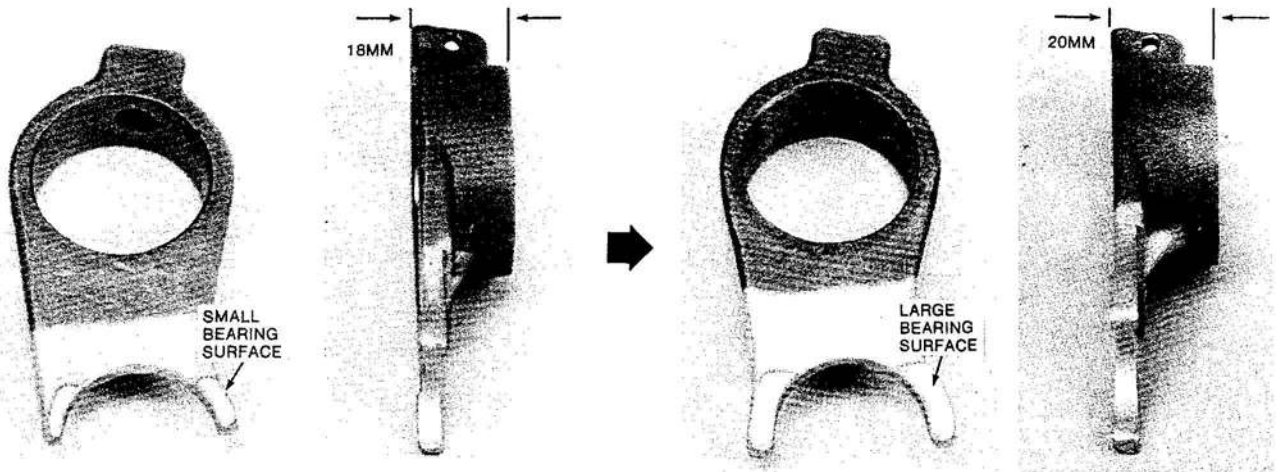

Shift Fork, Gear Groove Wear

Measure the thickness of the ears of each shift fork, and measure the width of the shift fork groove on gear D2 and the slider on the output shaft. If the thickness of a shift fork ear is under the service limit, it must be replaced. If the groove in the slider or gear D2 is wider than the service limit, the part must be replaced.

Shift Fork Thickness

Standard	Service Limit
4.8 - 5.0mm	4.7mm

Groove Width

Standard	Service Limit
5.05 - 5.15mm	5.25mm

Shift Drum Wear

Measure the width of the grooves in the shift drum at several points. Be sure to hold the calipers perpendicular to the direction of the groove at the point measured. If the groove is wider than the service limit, replace the drum.

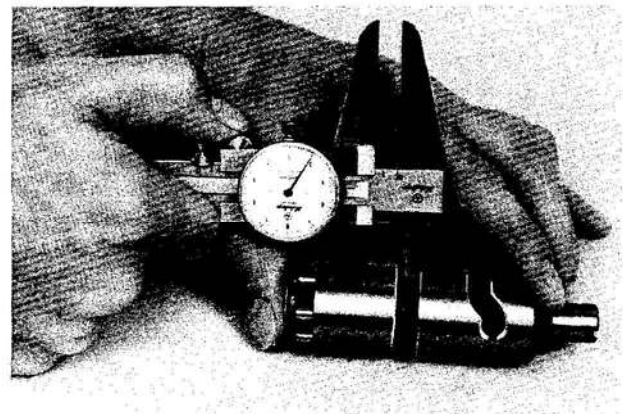

Shift Drum Groove Width

Standard	Service Limit
8.05 - 8.20mm	8.25mm

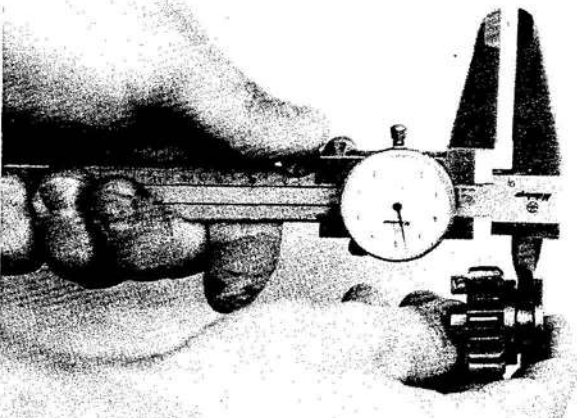

Gear Dog, Gear Dog Recess Damage

Visually inspect the gear dogs and gear dog recesses. Replace any gears that have damaged or unevenly or excessively worn dogs or dog recesses.

Gear/Shaft Wear

Measure the diameter of each shaft with a micrometer, and measure the inside diameter of each gear listed below. Find the difference between the two readings to figure clearance, and replace any gear where clearance exceeds the service limit.

Gear/Shaft Clearance

	Standard	Service Limit
O1	0.016 - 0.045mm	0.145mm
O2	0.020 - 0.062mm	0.162mm
D3	0.016 - 0.045mm	0.145mm

Output Shaft/Collar Clearance

Measure the diameter of the output shaft with a micrometer, and measure the inside diameter of the collar. Find the difference between the two readings to figure the clearance, and replace the collar if the clearance exceeds the service limit.

Output Shaft/Collar Clearance

Standard	Service Limit
0.016 - 0.052mm	0.152mm

KICKSTARTER

The schematic drawing of the kickstarter shows how the gear train carries the rotation of the kickstarter shaft to the crank shaft. When the kickstarter shaft turns, the pawl turns the kick starter gear concentric with the shaft. The kickstarter gear turns the idle gear mounted in the right hand side cover. The idle gear turns the small gear mounted on the face of the input shaft drive gear, which turns the primary pinion. The primary pinion has a non-return bearing in it that turns the bushing on the crankshaft. This bushing turns the crankshaft because it is pinched between the crankshaft oil seal collar and the clutch housing, by the clutch nut. When the engine starts, the crank shaft turns the bushing inside of the non-return bearing without turning the primary pinion. The primary pinion will not turn until the clutch engages with increased engine speed.

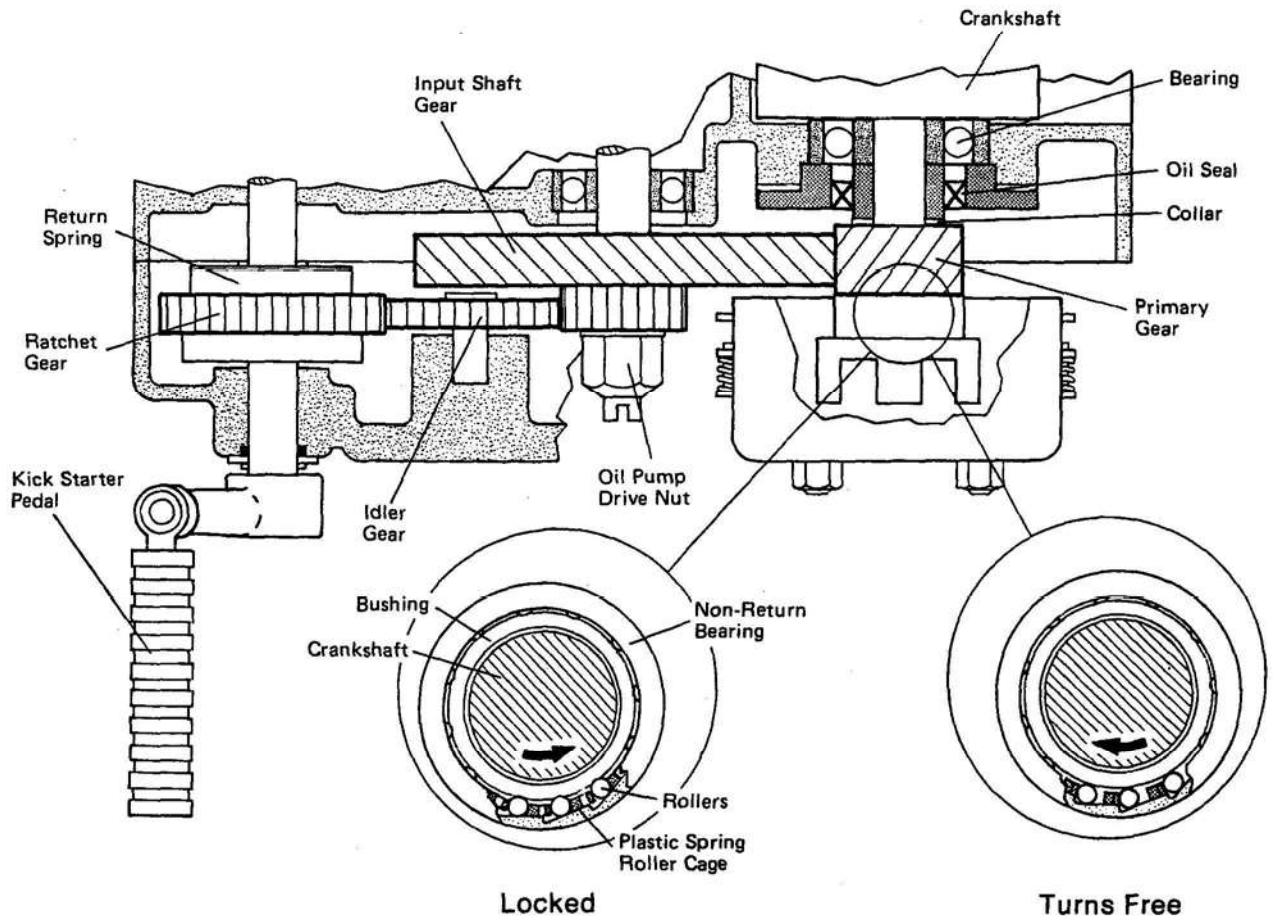

When the kick pedal is released, the kick shaft is turned by the return spring until the kick shaft lever strikes the stopper mounted in the right hand side cover, whereupon the pawl rides up on the stopper, breaking away from the kick gear. The kick gear now turns freely.

If the kick pedal return spring weakens or breaks, the kick pedal will not return completely or at all, and the kick gear and the pawl will stay partially meshed, making noise while engine is running. Kick mechanism noise may also result when the kick gear, idle gears, kick shaft, drive shaft, or output shaft becomes worn.

If the ratchet, pawl, or pawl spring is worn or damaged, the kick gear will slip, and it will not be possible to kickstart the engine.

Pawl, Pawl Spring Damage

Visually inspect the pawl and the pawl spring. If either one is damaged or badly worn, it must be replaced.

Put the pawl and pawl spring into place on the kick shaft, and push the pawl by hand. If the pawl will not return smoothly, replace the pawl, pawl spring, and pawl plunger.

OIL PUMP

The oil pump is a plunger type of pump, which supplies oil to lubricate the cylinder, piston, and crank chamber parts by pumping oil from the oil tank to the fuel/air mixture being drawn into the engine from the carburetor. In this type of lubrication system, called the Kawasaki Superlube System, the oil pump output is controlled to regulate the ratio of oil to fuel/air mixture so that proper lubrication is achieved at all engine speeds and loads.

The oil pump output is controlled partially by the number of plunger strokes. The number of plunger strokes is determined by the speed of oil pump rotation. Since crankshaft rotation is transmitted through the primary gear, input drive gear, and to the oil pump drive nut, the oil pump output changes in direct proportion to engine r.p.m. While the transmission is in neutral, the oil pump turns all the time. When the transmission is in gear, the oil pump turns only when the motorcycle is in motion.

The other factor that controls oil pump output is the plunger stroke length. This length is determined by the oil pump cam position, which is controlled by the throttle grip through the throttle grip and oil pump cables. As the cam is turned from minimum to maximum flow, plunger movement increases. A greater plunger stroke will pump more oil. Since the throttle grip cable, which pulls on the oil pump cable, is also connected to the carburetor cable, the oil pump output changes with the throttle valve opening.

The oil input to the pump is supplied by a hose from the oil tank, and the output from the pump goes through the output hose and then into the non-return check valve at the banjo bolt connection on the carburetor holder. The oil under pressure, opposes the spring tension on the ball that blocks the valve inlet, flows through the valve and is then ejected through a nozzle into the fuel/air mixture from the carburetor.

The oil pump is designed so that, at zero throttle when the pump is functioning properly, the oil pump lever mark aligns with the mark on the lever stopper, and both the oil pump output that is dependent on the length of the plunger stroke and the throttle valve opening are at their minimum. From this base position the pump lever and the throttle valve move at the same rate as the throttle opens. Any disturbance in this relationship will make the oil pump output too high or too low in relation to the throttle valve opening, resulting in poor performance and spark plug trouble from overlubrication or piston seizure from underlubrication.

Pump malfunction is generally caused by a deteriorated or damaged O-ring or oil seal since the other oil pump parts, being well lubricated by the oil passing through the pump, wear very little and seldom become damaged. A defective part reduces oil pump performance, resulting in underlubrication. Also, air trapped in an oil hose or the pump itself or a clogged check valve obstructs the flow of oil and results in underlubrication.

Any good quality 2 stroke engine oil that is recommended for air cooled engines may be used for the Superlube System. Some other type of oil, such as ordinary motor oil or transmission oil, is not acceptable as a substitute for the proper oil. Poor quality or the wrong type of oil may cause serious engine damage.

Bleeding the Oil Pump

When either of the oil pump hoses has been removed, air may become trapped inside, which will obstruct oil flow. See that oil flows from the inlet hose before reconnecting it to the pump. Bleed the air from the outlet hose by idling the engine (below 2,000 rpm) while holding the oil pump control lever fully open by hand in order to maximize the plunger stroke. Keep the engine idling until the air is completely pumped out. If air bubbles continue to appear in the output hose, check the oil hose connections at the pump.

64 MAINTENANCE - ENGINE BEARINGS

Oil Pump Performance Test

If a drop in oil pump performance is suspected, check the rate that the oil is being pumped.

- Remove the oil pump cover.
- Detach the banjo bolt from the carburetor holder, and run the outlet hose into a container.
- **USE A 20:1 MIXTURE OF GASOLINE TO OIL IN THE FUEL TANK IN PLACE OF THE GASOLINE NORMALLY USED.**
- Attach an instrument for measuring engine rpm to the magneto end of the crankshaft, and start the engine. Using the throttle grip friction adjuster, set the engine at 2,000 rpm.
- Holding the oil pump lever fully open by hand, collect the oil that is being pumped for 3 minutes. If the quantity of oil collected corresponds to the value the table shows, the oil pump is operating properly.

Oil Pump Output

Output/3 minutes at 2,000 rpm
1.4 - 1.7cc

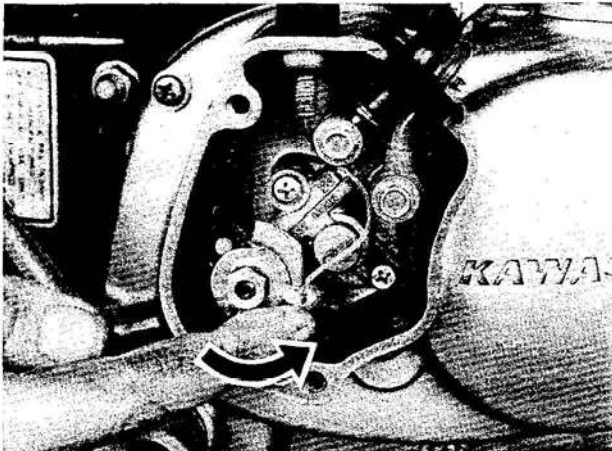

- If the oil pump output is subnormal, disassemble the pump, inspect the O-rings and oil seal, and replace if defective. If the trouble is with parts other than the O-rings or oil seal, replace the oil pump as an assembly. The pump is precision made with no allowance for replacement of individual parts.

Check Valve

If oil will not pass through the check valve, clean the valve out by using high flash-point solvent in a syringe. Do not use compressed air on the valve since doing so would damage the valve spring. If the check valve does not work properly after being cleaned out, either allowing oil to pass in both directions or not allowing oil to pass at all, replace the check valve.

Check Valve

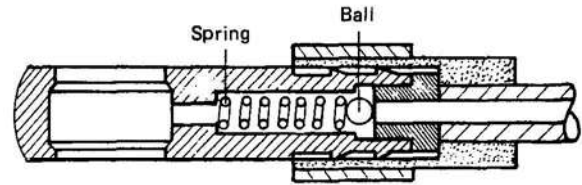

ENGINE BEARINGS, BUSHINGS, AND OIL SEALS

The engine bearings, bushing, and oil seals are listed in the tables. Worn or damaged bearings and bushings cause engine noise, power loss, and vibration, adversely affect engine and transmission parts, and shorten engine life. The crankshaft oil seals serve to seal the crank chamber, and if damaged will permit leaks to the crank chamber, causing a loss of power. Also, the crankshaft oil seal in the rotary valve cover forms a seal between the crank chamber and the transmission part of the crankcase, and if damaged will allow oil to be drawn into the crank chamber, causing running problems from an overly rich mixture. Any damaged, hardened, or otherwise defective oil seals will allow oil to leak.

Bearing Wear, Damage

Since the bearings are made to extremely close tolerances, the clearance cannot be measured normally. Therefore, the condition of the bearings must be judged by feel. Wash the bearing with high flash-point solvent, dry it (do not spin it while it is dry), and oil it. Spin it by hand to check its condition. If it is noisy, does not spin smoothly, or has any rough spots, it must be replaced. Before reinstalling the bearing, replace its oil seal with a new one. Press in the bearing so that its face is level with that of the crankcase.

Oil Seal Damage

Inspect the oil seals, and replace any if the lips are misshapen, discolored (indicating the rubber has deteriorated), hardened, or otherwise damaged. Since an oil seal is nearly always damaged on removal, any removed oil seals must be replaced. When pressing in an oil seal which is marked, press it in with the mark facing out. Press it in until the oil seal stops.

Crankcase Oil Seals

Crankshaft		Output Shaft	Shift Shaft	Shift Drum
Right	Left			
TB24358	TB20358	SB223255	SB12205	VB14246

Crankcase Bearings

Crankshaft		Drive Shaft		Output Shaft	
Left	Right	Left	Right	Left	Right
No. 6204	No. 6303	No. TLA1210	No. 6203	No. 6203	No. TLA1210

MUFFLER

The muffler reduces exhaust noise and conducts the exhaust gases back away from the rider while keeping power loss to a minimum. If much carbon is built up inside the muffler, exhaust efficiency is reduced, which lowers the engine output power.

To remove built up carbon, first remove the muffler, and then take off the tailpiece. Dangle a chain in the muffler and knock loose the carbon inside.

If there is any exhaust leakage where the muffler connects to the cylinder, or if the muffler gasket appears damaged, replace the gasket. A muffler that is badly damaged, dented, cracked, or rusted must be replaced.

TIRES

The tires are designed to give a smooth ride without slipping when they are inflated to the correct pressure and not overloaded.

If the tires are inflated to too high a pressure, riding becomes rough, the center portion of the tread wears quickly, and the tires are easily damaged.

If inflation pressure is too low, the shoulder portions wear quickly, the cord suffers damage, fuel consumption is high, and handling is poor. In addition, heat builds up and the tire life is greatly shortened.

To ensure safe handling and stability, use only the recommended standard tires for replacement, inflating them to the standard pressure. Also, a certain variation from the standard pressure may be desired depending on riding surface conditions (rain, ice, rough surface, etc.).

**Tire Air Pressure
(measured when cold)**

	Air Pressure	Size	Type, Marking
Front and Rear	1.0 kg/cm (14psi)	3.50-8 2PR	Trail Wing-2, BS

Tire Wear, Damage

Tires must not be used until they are bald, or if they are cut or otherwise damaged. As the tire treads wear down, the tire becomes more susceptible to puncture and failure. Ninety percent of tire failures occur during the last 10% of tire life.

Visually inspect the tire for cracks and cuts, replacing the tire in case of bad damage. Remove any imbedded stones or other foreign particles from the tread. Swelling or high spots indicate internal damage, requiring tire replacement unless the damage to the fabric is very minor.

Measure the depth of the tread with a depth gauge, and replace the tire if tread depth is less than the service limit.

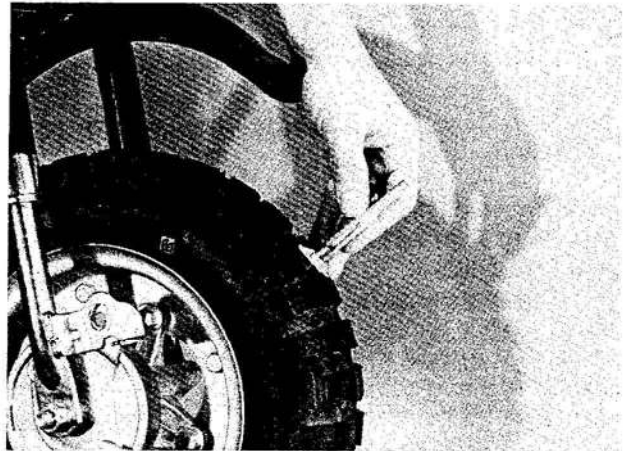

Tire Tread Depth

Standard	Service Limit
6.2mm	1.0mm

WHEELS AND AXLES

Rim Runout

Set a dial gauge to the side of the rim, and rotate the wheel to measure axial runout. The difference between the highest and lowest dial reading is the amount of runout.

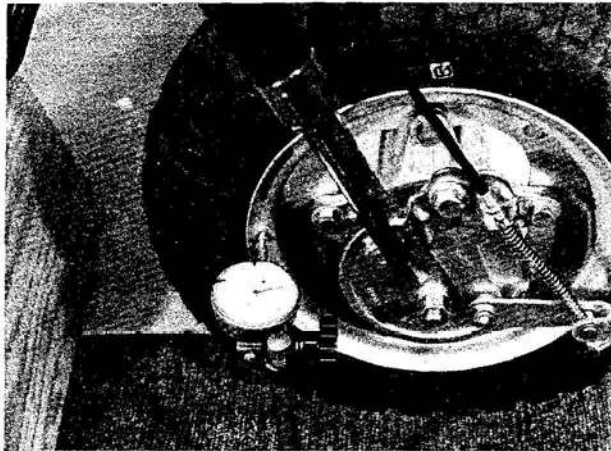

Set the dial gauge to the inner circumference of the rim, and rotate the wheel to measure radial runout. The difference between the highest and lowest dial reading is the amount of runout.

Rim Runout

	Standard	Service Limit
Axial	under 0.8mm	3.0mm
Radial	under 1.0mm	2.0mm

If the rim is warped past the service limit, replace it.

Axle Runout

A bent axle causes vibration, poor handling, and instability.

To measure axle runout, remove the axle, place it in V blocks that are 100mm apart, and set a dial gauge to the axle at a point halfway between the blocks. Turn the axle to measure the runout. The amount of runout is the amount of dial variation.

If runout exceeds the service limit, straighten the axle or replace it. If the axle cannot be straightened to within tolerance, or if runout exceeds 0.7mm, replace the axle.

Axle Runout/100mm

	Standard	Service Limit	Repair Limit
Front	under 0.1mm	0.2mm	0.7mm
Rear	under 0.05mm	0.2mm	0.7mm

Wheel Bearings

A wheel bearing is fitted in both sides of each hub. Since worn wheel bearings will cause play in the wheel, vibration, and instability, they should be cleaned, inspected, and greased periodically.

Since the wheel bearings are made to extremely close tolerances, the clearance cannot normally be measured. Wash the bearing with a high flash-point solvent, dry it (do not spin it while it is dry), and oil it. Spin it by hand to check its condition. If it is noisy, does not spin smoothly, or has any rough spots, it must be replaced. If the same bearing is to be used again, re-wash it with a high flash-point solvent, dry it, and pack it with good quality bearing grease before installation. Turn the bearing around by hand a few times to make sure the grease is distributed uniformly inside the bearing, and wipe the old grease out of the hub before bearing installation. Clean and grease the wheel bearings in accordance with the Periodic Maintenance Chart (p. 77).

Wheel Bearings.

All	6201Z
-----	-------

BRAKES

The front and rear wheels are both equipped with a leading-trailing type of drum brake. "Leading-trailing" means that one of the two brake shoes leads, expanding against the drum in the direction of drum rotation, and the other shoe trails, expanding in the direction opposite drum rotation.

Rear Brake

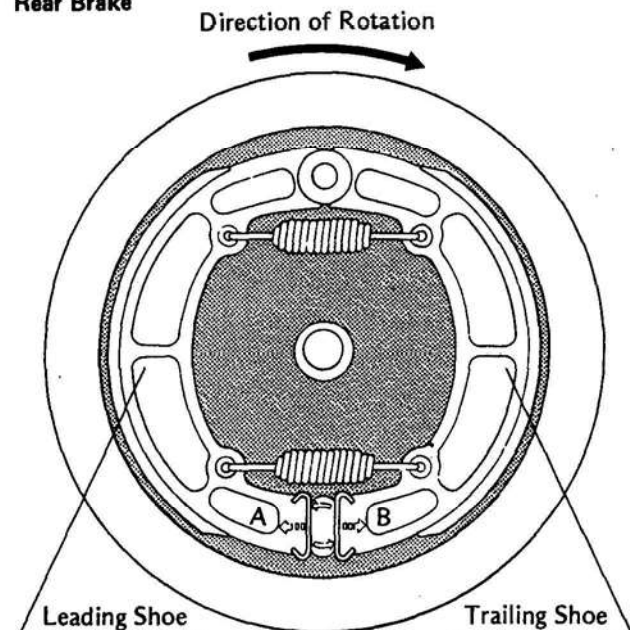

On both the front and rear brakes, the force applied by the rider upon braking is transmitted into the interior of the brake by a camshaft. The force applied at the brake lever is transmitted by a cable to the cam lever which then turns the camshaft. When the camshaft rotates, the large portion of the cam is forced between the two brake shoes. Since the shoes are only held together away from the drum by springs, the cam, overcoming spring tension, pushes the shoes outward against the drum. The leading shoe rotates in direction "A", and the trailing shoe in direction "B" as shown in the diagram.

Due to wear of the brake drum, shoes, and cam, periodic brake adjustment is required. However, if the brake parts become overworn, adjustment will not be sufficient to ensure safe brake operation. Not only can overworn parts break, but if wear allows the cam to turn so far that it is nearly horizontal when the brake is fully applied, the brake may lock in the operated position, or brake lever return may be very sluggish. All the brake parts should be checked for wear in accordance with the Periodic Maintenance Chart (p. 77).

Brake Drum Wear

Measure the inside diameter of the brake drum with calipers to determine wear. Since uneven drum wear will decrease braking effectiveness, take measurements at a minimum of two places. If the drum is worn unevenly, or if it is scored, replace it. If any diameter measurement exceeds the service limit, replace the drum.

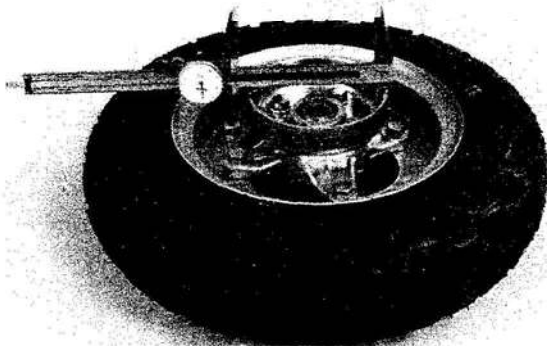

Brake Drum Inside Diameter

Standard	Service Limit
104.85 - 105.15mm	105.70mm

Brake Shoe Lining Wear

Check the thickness of the brake linings, and replace both shoes as a set if the thickness at any point is less than the service limit. If the thickness of the brake linings is sufficient, check the linings for uneven wear, and file or sand down any high spots. With a wire brush, remove any foreign particles imbedded in the lining surface. Wash off any oil or grease with a high flash-point solvent. In case the linings are damaged or the surface cannot be restored by sanding and cleaning, the shoes must be replaced.

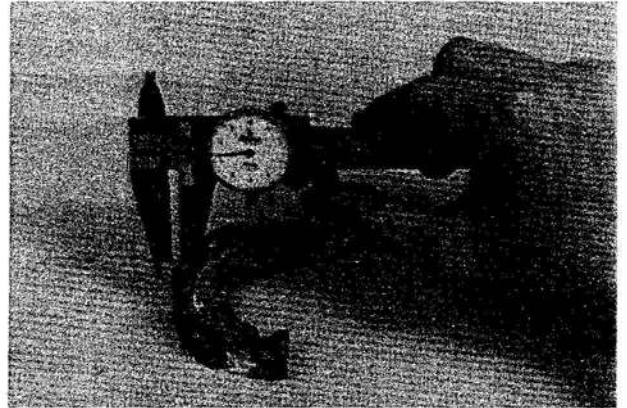

Brake Lining Thickness

Standard	Service Limit
3.7mm	1.9mm

Brake Shoe Spring Tension

If the brake springs become stretched, they will not pull the shoes back away from the drum after the brake lever or pedal is released, causing the shoes to drag on the drum. Remove the springs, and check their free length with vernier calipers. If either is stretched beyond the service limit, replace both springs.

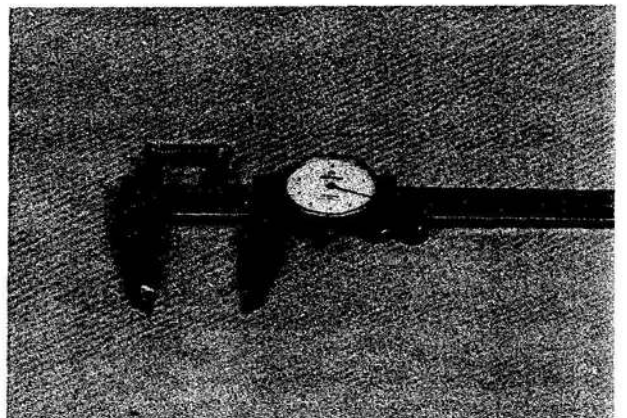

Brake Shoe Spring Length

Standard	Service Limit
29.7 - 30.3mm	31.5mm

68 MAINTENANCE - DRIVE CHAIN

Lubrication

Every time that the brakes are disassembled, and in accordance with the Periodic Maintenance Chart (p. 77), wipe out the old grease, and re-grease the brake pivot points. Apply grease to the brake shoe anchor pins, spring ends, and cam surface of the camshaft. Do not get any grease on the brake shoe linings, and wipe off any excess grease so that it will not get on the linings or drum after brake assembly.

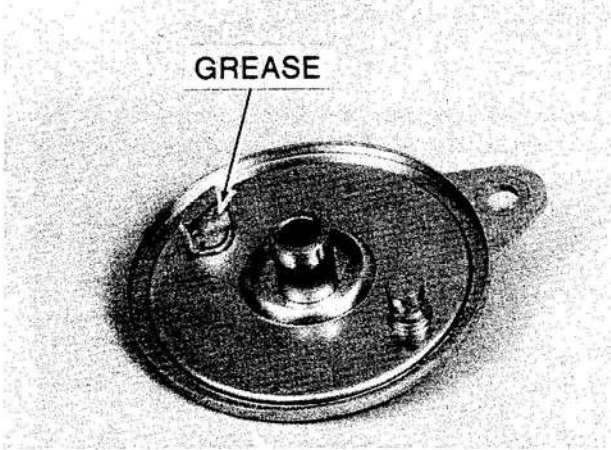

DRIVE CHAIN

The drive chain is used to transmit the engine power to the rear wheel, and is provided with a master link to facilitate removal and replacement. To minimize any chance of the master link dislodging, the master link is fitted with the closed end of the "U" pointing in the direction of chain rotation.

Master Link Clip Installation

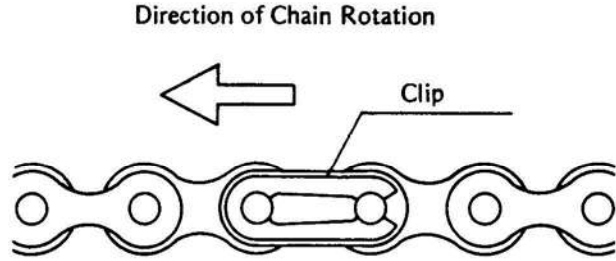

Chain construction is shown in the illustration. Most chain wear occurs between the pins and bushings, and between the bushings and rollers, rather than on the outside of the rollers. This wear causes the chain to lengthen. If the chain is left unadjusted, the lengthening will lead to noise, excessive wear, breakage, and disengagement from the sprockets. If the chain is allowed to wear too much, the distance from roller to roller is so much greater than the distance between each tooth of the sprocket, that the wear rapidly accelerates.

The rate of wear can be greatly reduced, however, by frequent and adequate lubrication, especially between the side plates of the links so that oil can reach the pins and bushings inside the rollers.

Wear

When the chain has worn so much that it is more than 2% longer than when new, it is no longer safe for use and should be replaced.

Drive Chain

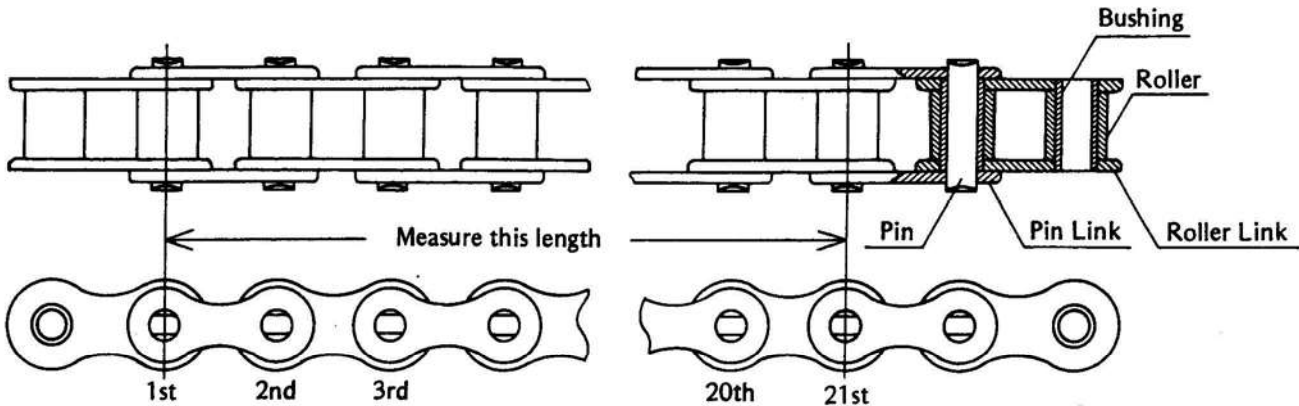

Whenever the chain is replaced, inspect both the engine and rear sprockets and replace them if necessary. Overworn sprockets will cause a new chain to wear quickly.

Since it is impractical to measure the entire length of the chain, determine the degree of wear by measuring a 20 link length of the chain. Stretch the chain taut either by using the chain adjusters or by hanging a 10 kg weight on the chain. Measure the length of 20 links on a straight part of the chain from pin center of the 1st pin to pin center of the 21st pin. If the length is greater than the service limit, the chain should be replaced.

NOTE: The drive system was designed for use with the standard chain. For maximum strength and safety, the standard chain must be used for replacement.

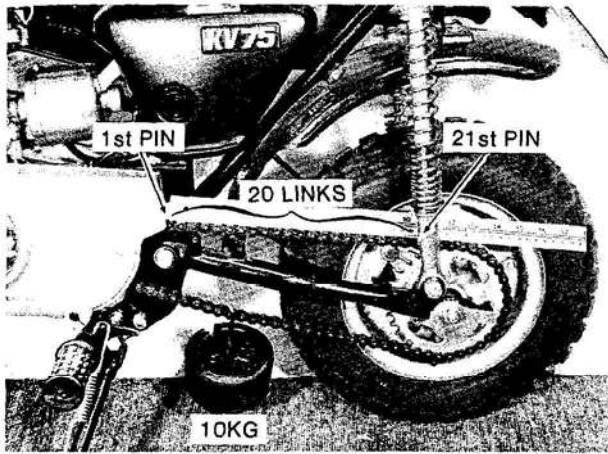

Drive Chain

Type	Size	Length
Master Link	420	88 links

Drive Chain Wear

	Standard	Service Limit
20 Link Length	254mm	259mm

Lubrication

In order for the chain to function safely and wear slowly, it should be properly lubricated in accordance with the Periodic Maintenance Chart (p. 77). Lubrication is also necessary after riding through rain or on wet surfaces, or any time that the chain appears dry. Anytime that the motorcycle including the chain has been washed, the chain should be adequately lubricated on the spot in order to avoid rust.

The chain should be lubricated with a lubricant which will both prevent the exterior

from rusting and also absorb shock and reduce friction in the interior of the chain. An effective, good quality lubricant specially formulated for chains is best for regular chain lubrication. If a special lubricant is not available, a heavy oil such as SAE 90 is preferred to a lighter oil because it will stay on the chain longer and provide better lubrication. Apply the oil to the sides of the rollers and between the side plates of the links so that oil will penetrate to the pins and bushings where most wear takes place. Wipe off any excess oil.

Dirt will cling to the oil and act as an abrasive, accelerating chain wear. Whenever the chain becomes particularly dirty, it must be cleaned in kerosene and then soaked in a heavy oil. Shake the chain while it is in the oil so that oil will penetrate to the inside of the rollers.

SPROCKETS

There are two sprockets for the drive chain. A forward sprocket, or engine sprocket, is mounted on the end of the output shaft and is used to drive the chain. A rear sprocket is connected to the rear wheel hub and is driven by the chain to turn the rear wheel.

Sprockets that have become excessively worn cause noise with the chain and greatly accelerate chain and sprocket wear. The sprockets should be checked for wear any time that the chain is replaced. A warped rear sprocket destroys chain alignment such that the chain may break or jump from the sprockets when traveling at high speed. The sprockets should be checked for wear and the rear sprocket for warp any time that the chain is replaced.

Sprocket Wear

Visually inspect the sprocket teeth. If they are worn as illustrated, replace the sprocket.

Sprocket Teeth

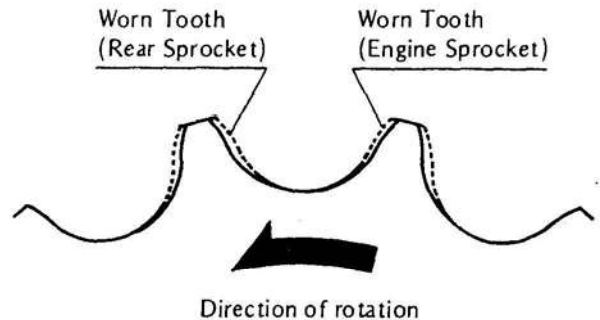

NOTE: If a sprocket requires replacement, the chain is probably worn also. Upon replacing a sprocket, inspect the chain.

70 MAINTENANCE - STEERING STEM

Measure the diameter of the sprocket at the base of the teeth. If the sprocket is worn down to less than the service limit, replace the sprocket.

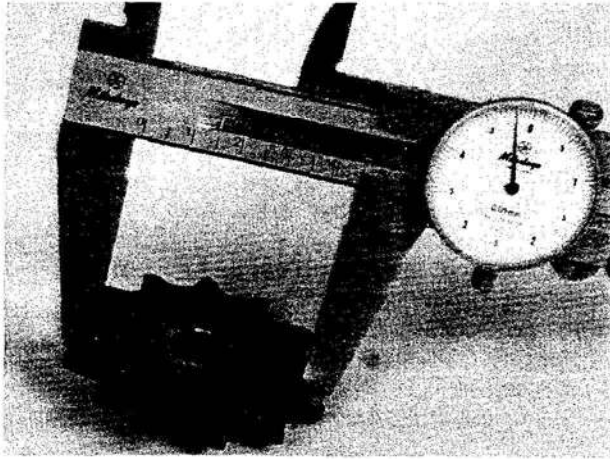

Sprocket Diameter

	Standard	Service Limit
Engine	45.1 - 45.3mm	44.5mm
Rear	125.53 - 125.83mm	125.00mm

Rear Sprocket Runout

Elevate the rear wheel so that it will turn freely, and set a dial gauge against the rear sprocket near the teeth as shown. Rotate the rear wheel. The difference between the highest and lowest dial gauge readings is the amount of runout (warp).

If the runout exceeds the service limit, replace the rear sprocket.

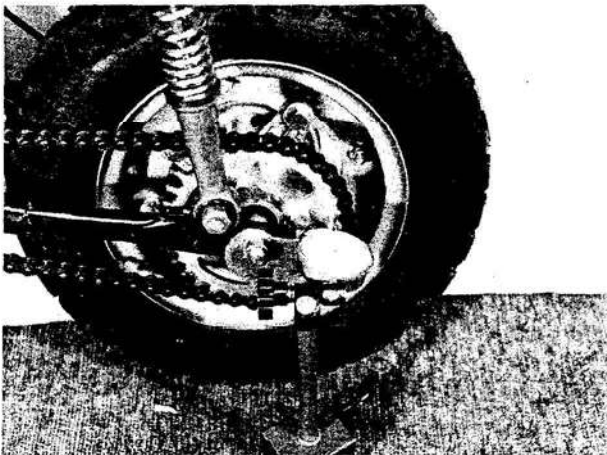

Rear Sprocket Runout

Standard	Service Limit
under 0.4mm	0.5mm

STEERING STEM

The steering stem supports the handlebar, front fork legs, and front fender, and turns inside the frame head pipe. Ball bearings in the upper and lower ends of the head pipe enable the steering stem to turn smoothly and easily.

The steering stem itself does not wear, but it may become bent. If it becomes bent, the steering will be stiff, and the bearings may become damaged.

The steering stem will require periodic adjustment as it becomes loose due to bearing wear. Overtightening during adjustment, however, will make the steering stiff and cause accelerated bearing wear. Lack of proper lubrication will also bring about the same results.

From overtightening or from a heavy shock to the steering stem, the bearing race surfaces may become dented. Damaged bearing races will cause the handlebar to jerk or catch when turned.

Steering Stem Warp

Examine the steering stem, and replace it if it is bent.

Bearing Wear, Damage

Wipe the bearings clean of all dirt and grease. Turn them by hand to check for roughness or play. If the bearings do not turn smoothly and without play, replace them both.

Bearing Lubrication

In accordance with the Periodic Maintenance Chart (p. 77), and whenever the steering stem is disassembled, the steering stem bearings should be relubricated.

Wipe all the old grease off the races and balls, washing them in high flash-point solvent if necessary. Replace the bearings if they show wear or damage. Apply grease liberally to the bearings and then install them.

FRONT FORK

The front fork consists of two shock absorbers connected to the frame head pipe by the steering stem and the stem head bracket. It accomplishes shock damping through spring action. Each shock absorber (fork leg) is a telescopic tube including an inner tube, an outer tube, and a spring. The forks cannot be disassembled. If they are bent or otherwise damaged, or if they do not support the front of the motorcycle properly, replace the front fork as an assembly.

REAR SUSPENSION

Rear Shock Absorbers

The rear shock absorbers serve to dampen shock transmitted to the frame and rider from the rear wheel. For this purpose they are connected between the frame and the rear end of the swing arm. Shock absorption is performed by the spring.

On early models, the rear shocks may be disassembled for lubrication by unscrewing the spring holder on the top end of the shock. Coat the rod with a thin film of chassis grease. On 1973 and later models, the shocks can not be disassembled.

Bushings

Check the rubber bushings, and replace any that are worn, cracked, hardened, or otherwise damaged.

Swing Arm

The swing arm is designed to work with the shock absorbers to dampen the shock to the frame from the rear wheel. The rear end of the swing arm is connected to the frame by the rear shock absorbers, while the front end through rubber dampened bushings pivots on a shaft connected to the frame. When the rear wheel receives a shock, the swing arm, pivoting on its shaft, allows the wheel to move up and down in relation to the frame within the limits of the shock absorbers.

Each bushing consists of rubber cemented between steel sleeves. The outer sleeve is press fitted to the swing arm and the inner sleeve is fitted around the pivot shaft and pressed against the frame. The movement of the swing arm in relation to the frame is permitted by the elasticity of the rubber.

Since the pivoting of the swing arm depends on the bushing rubber, there are no wearing parts requiring lubrication. However, as the rubber deteriorates and loses its resiliency, a resulting looseness between the swing arm and the pivot shaft will adversely affect motorcycle stability.

Bushing

Visually inspect the bushings in the swing arm. If they are deteriorated or damaged, they must be replaced.

Measure the inside diameter of the bushings and the outside diameter of the shaft. If the bushing I.D. is greater, or the shaft O.D. is less, than the service limit, replace the parts.

Pivot Shaft, Bush Diameter

	Standard	Service Limit
Shaft O.D.	9.93 - 10.00mm	9.90mm
Bush I.D.	10.10 - 10.25mm	10.40mm

Swing Arm

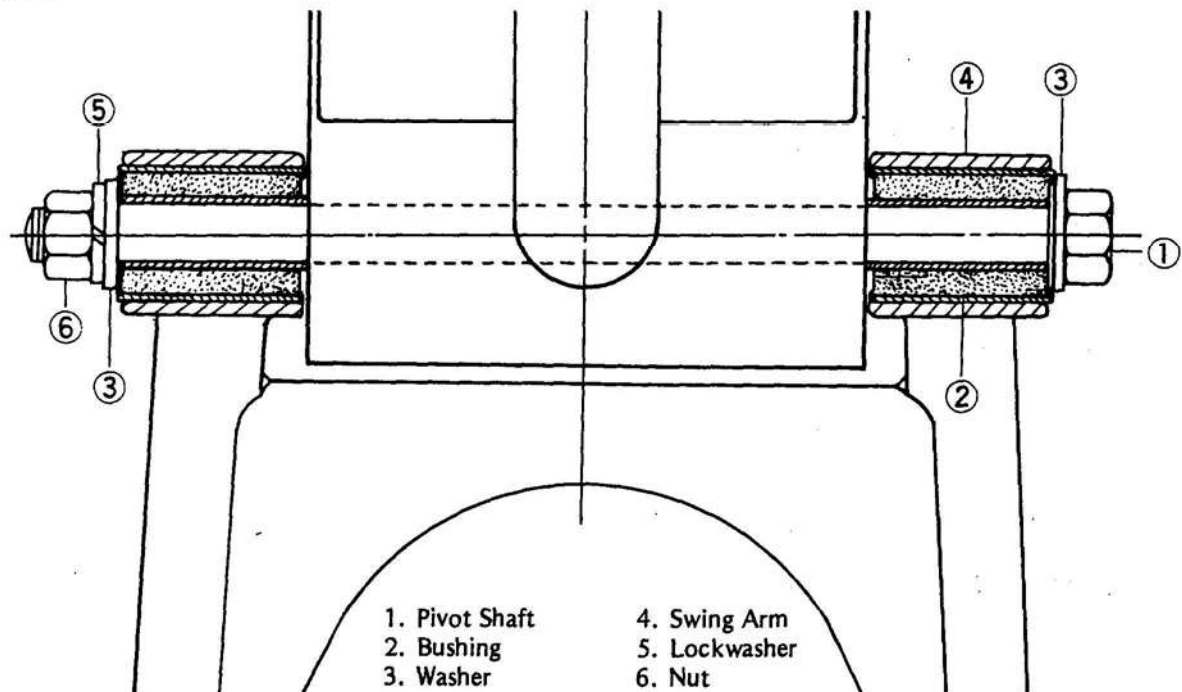

Pivot Shaft

To measure the pivot shaft runout, set the pivot shaft on V blocks at the ends of the shaft, and set the dial gauge to the shaft halfway between the blocks. Turn the shaft to measure the runout. The amount of runout is the amount of dial variation. If the shaft is bent, straighten it. If it cannot be straightened, or if the dial gauge shows a variation of more than 0.7mm, replace the shaft.

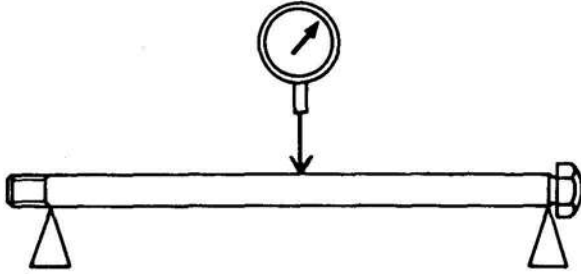
Pivot Shaft Runout**Pivot Shaft Runout**

Standard	Service Limit	Repair Limit
under 0.1mm	0.3mm	0.7mm

IGNITION SYSTEM

The ignition system is made up of a flywheel magneto, a high tension coil, a spark plug, and connecting wiring. The flywheel magneto has a rotating flywheel on the crankshaft carrying a set of magnets around two interconnected coils mounted on a stator plate. As the magnets move past the two coils, a current is induced in the coils. Current from one set of windings on the

coils is used for the lights; current from the other set is used to power the ignition system. A set of points and a capacitor are mounted on the stator plate between the coils and serve to trigger the ignition. When the points open, the current from the magneto coil that was shorted through the points to ground flows suddenly through the primary winding of the high tension coil. This current flow causes a magnetic field to build up around the primary windings. As the field builds, the magnetic lines of force cut through the secondary windings of the high tension coil. Because there are so many secondary windings, the current induced in them by the rising magnetic field is of a very high voltage. This high voltage current is routed to the spark plug, where it jumps the gap to ignite the fuel/air mixture in the combustion chamber.

Contact Breaker

When the points become dirty, pitted, or burned, or if the spring weakens, the points will not make the contact necessary to produce a good spark, resulting in unstable idling, misfiring, or the engine not running at all. Inspect the contact breaker, and repair or replace if necessary.

Clean the points with clean paper or cloth, or using an oil-free solvent. A business card soaked in trichloroethylene can be used to remove traces of oil. To repair light damage, use sandpaper or an oilstone. If the points are badly worn down or damaged, or if the spring is weak, replace the contact breaker.

Whenever the contact breaker is inspected or replaced, apply a small amount of grease to the felt to lubricate the cam in order to minimize wear of the contact breaker heel. Be careful not to apply so much grease that it can drop off or be thrown onto the points, which will cause the points to foul and burn.

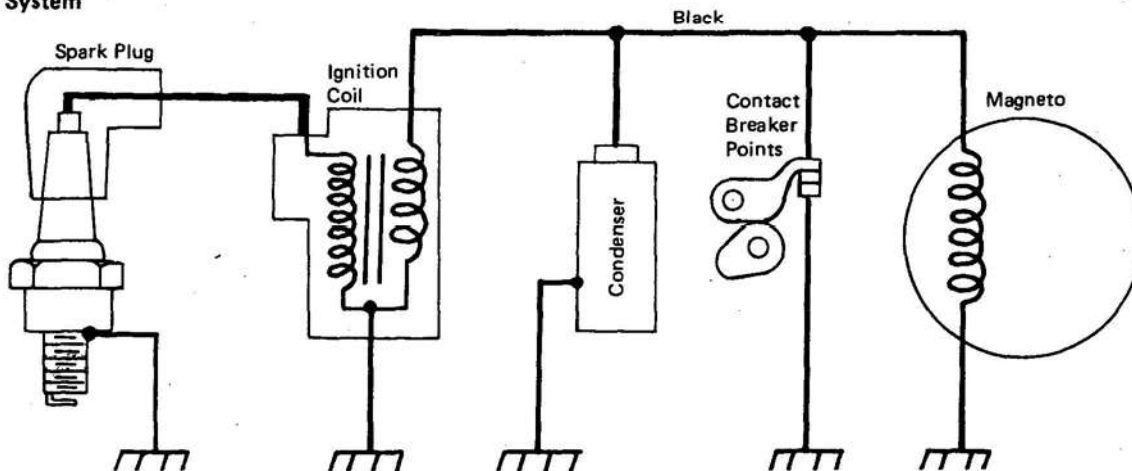
Ignition System

Capacitor

The capacitor can usually be considered to be defective if a long spark is seen arcing across the points as they open or if the points are burned or pitted for no apparent reason. Replace the capacitor any time it appears defective and whenever the contact breaker is replaced.

NOTE: For checking with a capacitor tester, capacitor specifications are: 0.25 ± 0.03 mfd., 1,000 WVDC.

Capacitor Test

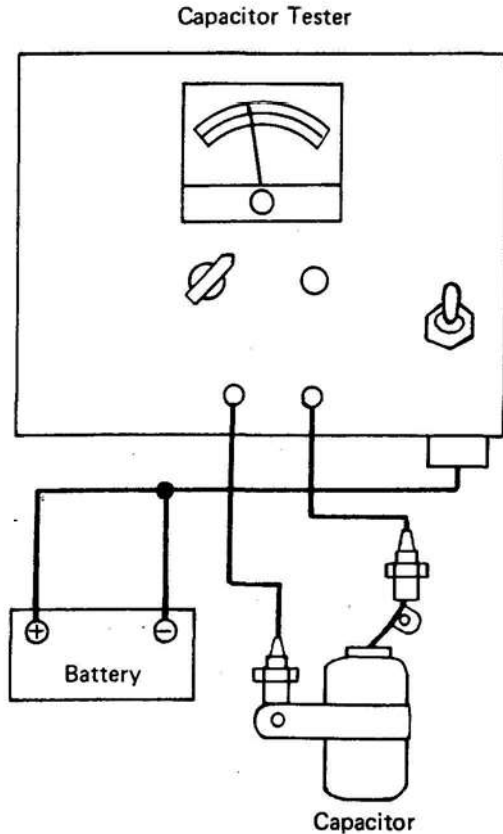

Ignition Coil Test

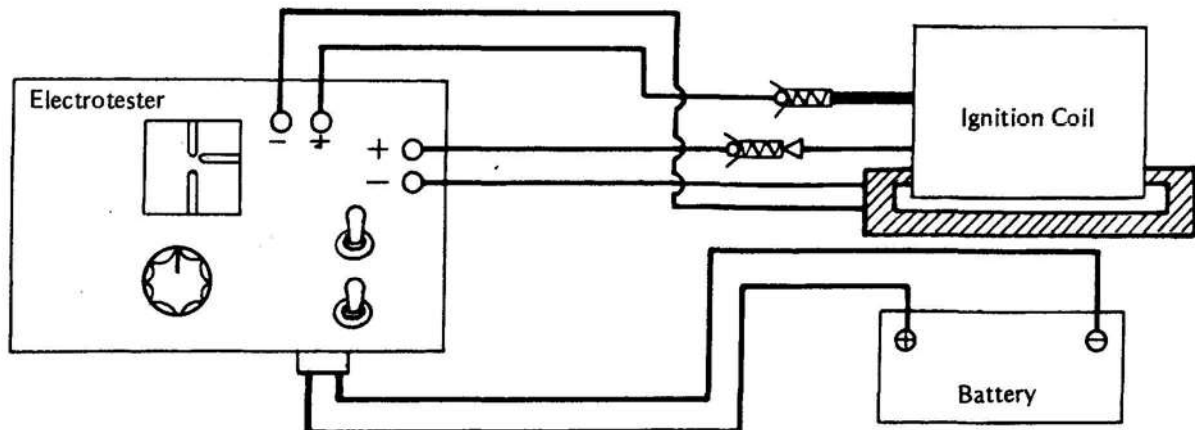

Ignition Coil

The most accurate test for determining the condition of the ignition coil is made with the Kawasaki electrotester. The ignition coil must be connected to the tester in accordance to the tester directions and should produce at least a 5mm spark. Since an electrotester may produce a different arcing distance, the Kawasaki electrotester is recommended for a reliable result.

If an electrotester is not available, the coil can be checked for a broken or a badly shorted winding with an ohmmeter. However, an ohmmeter cannot detect layer shorts and shorts resulting from insulation breakdown under high voltage.

To measure the primary winding resistance, set the ohmmeter to the R x 1 range, and connect one ohmmeter lead to ground and the other to the black lead from the ignition coil. The resistance should be $2.41 - 2.81 \Omega$. To measure the secondary winding resistance, set the ohmmeter to the R x 100 range, and connect one ohmmeter lead to ground and the other to the spark plug lead. The resistance should be about $10K\Omega$.

If the coil does not produce an adequate spark, or if either the primary or secondary winding does not have the correct resistance, replace the ignition coil.

Ignition Magneto Coil

If the spark is weak or non-existent after the spark plug, ignition coil, points, and capacitor are found to be all functioning properly, the wiring all in good condition and properly connected, and the ignition timing correctly adjusted, the cause may be a short or open in the ignition magneto coil or a loss of magnetism in the flywheel magnets.

- After removing the shift pedal and the left engine cover, rotate the flywheel until the points open.

- Pull out the magneto black lead from where it connects under the fuel tank to the ignition coil black lead.
- Set an ohmmeter to the R x 1 range, and measure the resistance between ground and the magneto black lead. The proper value is about 1.6Ω.

If the resistance in this test is found to be less than the proper value, there is a short in the ignition magneto coil. Discontinuity indicates an open. In either case, replace the ignition magneto coil. If the coil checks, good, the cause is probably a loss of magnetism in the flywheel, necessitating flywheel replacement.

Spark Plug

The spark plug ignites the fuel/air mixture in the combustion chamber. To do this effectively and at the proper time, the correct spark plug must be used, and the spark plug must be kept clean and adjusted.

Spark Plug

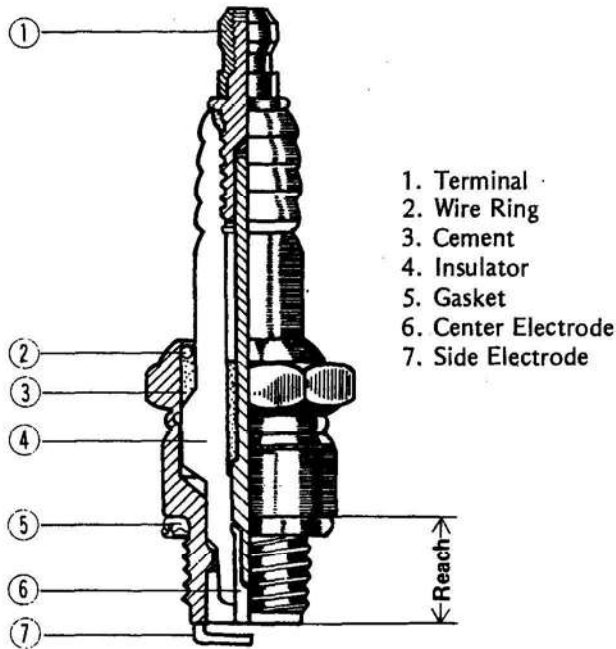

Tests have shown the NGK B-7HS, set to a 0.7mm (0.028 inch) gap to be the best plug for general use. But since spark plug requirements change with ignition and carburetion adjustments and with riding conditions, this plug may have to be replaced for one of the next higher or lower heat range. Whether or not a spark plug of a different heat range should be used is generally determined upon removing and inspecting the plug.

When a plug of the correct heat range is being used, the electrodes will stay hot enough

to keep all the carbon burned off but cool enough to keep from damaging the engine and the plug itself. This temperature is about 400 - 800°C (750 - 1450°F) and can be judged by noting the condition and color of the ceramic insulator around the center electrode. If the ceramic is clean and of a light brown color, the plug is burning at the right temperature.

A spark plug for higher operating temperatures is used for racing and other high speed applications. Such a plug is designed for better cooling efficiency so that it will not overheat and thus is often called a "colder" plug. If a spark plug with too high a heat range is used — that is, a "cold" plug that cools itself too well — the plug will stay too cool to burn off the carbon, and the carbon will collect on the electrodes and the ceramic insulator. If enough of this carbon collects, it may prevent a spark from jumping across the gap, or it may short the spark out by bridging across the electrodes or by conducting along the outside of the ceramic. Carbon build-up on the plug can also cause the electrodes to heat up red-hot, which will cause preignition, indicated by knocking, which in turn may eventually burn a hole in the top of the piston.

A spark plug in the lower heat range is used when engine temperature is comparatively low such as for constant city use or during the break-in period when the motorcycle is not operated at high speed. Such a plug is designed to hold the heat and thus is often referred to as a "hotter" plug. If a "hot" plug is used for racing or other high speed use, the plug will be too hot, causing engine overheating and preignition.

Inspection and Replacement

Remove the plug and inspect the ceramic insulator. If the insulator is clean and has a light brown color, the correct plug is being used. If it is fouled black, change to the "hotter" NGK B-6HS. If the ceramic is burned white and the electrodes are burned, replace the plug with the "colder" NGK B-8HS. However, if the spark plug still fouls or overheats after changing to a hotter or colder plug, the cause of the trouble may be other than the spark plug such as faulty carburetion or ignition timing.

CAUTION When the type of riding changes — for example, a change to faster riding after the break-in period is over — the spark plug should be inspected and changed if necessary. The NGK B-6HS plug in particular can damage the engine if used for high speed riding.

Clean the electrodes and the ceramic insulator around the center electrode by scraping off any deposits and cleaning the plug in gasoline. If the gap has widened, reset it to the standard 0.7mm (0.028 in.) gap. If the

electrodes are badly worn down or burned, replace the plug. The plug must also be replaced any time there is visible damage such as cracked ceramic or damaged threads.

Spark Plug Condition



Carbon Fouling

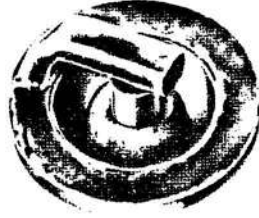

Oil Fouling



Normal Operation



Overheating

NOTE: If the spark plug is replaced by any other than the recommended NGK B-6HS, B-7HS (standard), or B-8HS, make sure that the replacement plug has the same:

- (1) thread pitch
- (2) reach (length of threaded portion must be 12.7mm (1/2 in.))
- (3) diameter (diameter at threads must be 14mm (9/16 in.))

Plug Reach

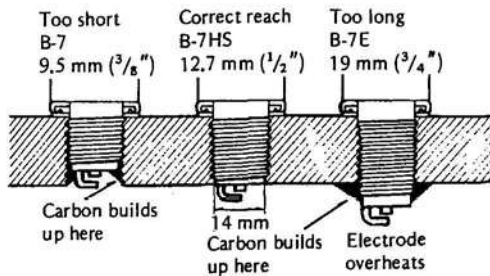

If a plug with the wrong thread pitch or thread diameter is used, the cylinder head will be damaged. If a plug with too long or short a reach is used, carbon will build up around the plug or plug hole threads, possibly causing engine damage and making the old plug difficult to remove or the new one difficult to install.

LIGHTING SYSTEM

The lighting system is composed of a set of windings on the magneto coils to power the system, wiring, switches, and a head light and taillight. The switch on the right handlebar turns the headlight and tail light on and off. The dimmer switch is on the left handlebar and changes the headlight beam.

If the headlight or tail light does not light, check to see if the bulb has burned out. If it has, replace it. If the bulb is good, check the light switch and the dimmer switch. Disconnect the leads to the switches, and check their operation with an ohmmeter. When the switch is turned on or to the beam position being checked, the meter should show zero ohms. Otherwise, it should show infinite ohms. If the switches are good, check all connections and the wiring. As a last resort, check the magneto coil. Check the resistance between the yellow lead and ground (magneto leads disconnected).

Lighting Coil Resistance

Meter Connections	Resistance
Yellow to Ground	1.6Ω

APPENDIX

PERIODIC MAINTENANCE

Periodic Maintenance Chart

Operation	Frequency	Whichever comes first							See Page	
	Every	1st month	6th month	12th month	18th month	24th month	30th month	36th month		
Brake adjustment—check		•	•	•	•	•	•	•	9	
Brake wear—check			•	•	•	•	•	•	67	
Carburetor and Oil pump—adjust		•	•	•	•	•	•	•	6	
Throttle cable—adjust		•	•	•	•	•	•	•	5	
Steering play—check		•	•	•	•	•	•	•	9	
Drive chain wear—check			•	•	•	•	•	•	68	
Front fork—inspect		•	•	•	•	•	•	•	70	
Rear shock absorbers—inspect		•	•	•	•	•	•	•	71	
Nuts, Bolts, Fasteners—check and torque		•		•		•		•	—	
Points, timing—check		•	•	•	•	•	•	•	7	
Air cleaner element—clean			•		•		•		48	
Air cleaner element—replace	5 cleanings			•		•		•	15	
Tire tread wear—check			•	•	•	•	•	•	65	
Transmission oil—change		•	•	•	•	•	•	•	—	
General lubrication—perform			•	•	•	•	•	•	—	
*Swing arm—lubricate				•		•		•	—	
*Wheel bearings—grease						•			66	
*Brake camshaft—grease						•			68	
*Steering stem bearings—grease						•			70	
Spark plug—clean and gap		•	Every 3 months						74	
Drive chain—lubricate		Before and after each day of operation								69
Drive chain—adjust		Every 2 months								10

*Should be service by an authorized Kawasaki Dealer.

The above table is based on a monthly average of an estimated 160 km (100 mile) of operation. Vehicle operation under severe conditions requires more frequent maintenance.

TROUBLESHOOTING GUIDE

ENGINE DOESN'T START: STARTING DIFFICULTY

Engine Won't Turn Over

- Cylinder, piston seizure
- Connecting rod small end seizure
- Connecting rod big end seizure
- Transmission gear or bearing seizure
- Kickstarter return spring broken
- Pawl not engaging with ratchet
- Non-return bearing in primary gear failure

No Fuel Flow

- No fuel in tank
- Fuel tap turned off
- Tank cap air vents obstructed or closed
- Fuel tap clogged
- Fuel line clogged
- Float valve clogged

78 APPENDIX - TROUBLESHOOTING GUIDE

Engine Flooded

Float level too high

Float valve worn or stuck open

Starting technique faulty

(When flooded, kick with the throttle fully open to allow more air to reach the engine.)

No Spark; Spark Weak

Spark plug dirty, defective, or maladjusted

Spark plug cap or high tension wiring defective

Spark plug cap shorted or not in good contact

Contact breaker points dirty or damaged

Capacitor defective

Ignition coil defective

Ignition timing maladjusted

Flywheel magneto defective

Engine stop switch shorted

Wiring shorted or open

Fuel/Air Mixture Incorrect

Air screw and/or idle adjusting screw maladjusted

Pilot jet or air passage clogged

Air cleaner clogged, poorly sealed, or missing

Starter jet clogged

Compression Low

Cylinder, piston worn

Piston rings bad (worn, weak, broken, or sticking)

Cylinder head gasket damaged

Cylinder head not sufficiently tightened down

Cylinder head warped

Spark plug loose

Crankshaft oil seal deteriorated or damaged

POOR RUNNING AT LOW SPEED

Spark Weak

Spark plug dirty, defective, or maladjusted

Spark plug cap or spark plug lead defective

Spark plug cap shorted or not in good contact

Contact breaker points dirty or damaged

Capacitor defective

Ignition coil defective

Ignition timing maladjusted

Flywheel magneto defective

Fuel/Air Mixture Incorrect

Air screw and/or idle adjusting screw maladjusted

Pilot jet or air passage clogged

Air cleaner clogged, poorly sealed, or missing

Starter plunger stuck open

Float level too high or too low

Compression Low

Cylinder, piston worn

Piston rings bad (worn, weak, broken or sticking)

Cylinder head gasket damaged

Cylinder head not sufficiently tightened down

Cylinder head warped

Spark plug loose

Crankshaft oil seal deteriorated or damaged

POOR RUNNING OR NO POWER AT HIGH SPEED**Firing Incorrect**

- Spark plug dirty, defective, or maladjusted
- Spark plug cap or spark plug lead defective
- Spark plug cap shorted or not in good contact
- Contact breaker points dirty or damaged
- Capacitor defective
- Ignition coil defective
- Ignition timing maladjusted
- Contact breaker spring weak

Fuel/Air Mixture Incorrect

- Main jet clogged or wrong size
- Jet needle or needle jet worn
- Jet needle clip in wrong position
- Float level too high or too low
- Air jet or air passage clogged
- Air cleaner clogged, poorly sealed, or missing
- Starter plunger stuck open
- Fuel to carburetor insufficient
- Water or foreign matter in fuel

Compression Low

- Cylinder, piston worn
- Piston rings bad (worn, weak, broken, or sticking)
- Cylinder head gasket damaged
- Cylinder head not sufficiently tightened down
- Cylinder head warped
- Spark plug loose
- Crankshaft oil seal deteriorated or damaged

Oil and Fuel/Air Mixture Incorrect

- Throttle control cable maladjusted
- Crankshaft oil seal deteriorated or damaged
- Oil pump defective
- Oil line or check valve clogged
- Air in oil pump or oil line

Knocking

- Ignition timing maladjusted
- Carbon built up in combustion chamber
- Fuel poor quality or incorrect

Miscellaneous

- Throttle valve won't fully open
- Muffler clogged
- Cylinder exhaust port clogged
- Brakes dragging
- Clutch slipping
- Overheating
- Transmission oil level too high
- Transmission oil viscosity too high
- Crankshaft bearing worn or damaged

OVERHEATING**Firing Incorrect**

- Spark plug dirty, damaged, or maladjusted
- Ignition timing maladjusted

Fuel/Air Mixture Incorrect

- Main jet clogged
- Float level too low
- Air cleaner clogged

80 APPENDIX - TROUBLESHOOTING GUIDE

- Oil and Fuel/Air Mixture Incorrect
 - Throttle control cable maladjusted
 - Oil pump defective
 - Oil line or check valve clogged
 - Air in oil pump or oil line
- Compression High
 - Carbon built up in combustion chamber
- Engine Load Faulty
 - Clutch slipping
 - Transmission oil level too high
 - Brakes dragging

FUEL AND OIL CONSUMPTION EXCESSIVE

- Idling Too Fast
 - Idle adjusting screw maladjusted
 - Throttle control cable catching or poorly adjusted.
- Fuel/Air Mixture Too Rich
 - Air screw maladjusted
 - Main jet too large
 - Jet needle or needle jet worn
 - Starter plunger stuck open
 - Float level too high
 - Air cleaner clogged
- Compression Low
 - Cylinder, piston worn
 - Piston rings bad (worn, weak, broken, or sticking)
 - Cylinder head gasket damaged
 - Cylinder head not sufficiently tightened down
 - Cylinder head warped
 - Spark plug loose
 - Crankshaft oil seal deteriorated or damaged
- Exhaust Obstructed
 - Muffler clogged
 - Cylinder exhaust port clogged
- Engine Load Faulty
 - Clutch slipping
 - Brakes dragging

CLUTCH OPERATION FAULTY

- Clutch Slipping
 - Friction plates worn
 - Clutch springs weak
 - Clutch hub or housing unevenly worn
- Clutch Not Disengaging Properly
 - Clutch plates warped or too rough
 - Clutch spring tension uneven
 - Transmission oil deteriorated
 - Transmission oil of too high a viscosity
 - Hub frozen on bushing

GEAR SHIFTING FAULTY

- Doesn't Go Into Gear; Shift Pedal Doesn't Return
 - Shift fork(s) bent or seized
 - Shift return spring weak or broken
 - Shift lever broken
 - Shift return spring pin loose
 - Shift drum broken

- Shift mechanism pawl spring broken
- Jumps Out of Gear
 - Shift fork(s) worn
 - Gear grooves(s) worn
 - Gear dogs and/or dog recesses worn
 - Shift drum groove(s) worn
 - Shift fork pin(s) worn
 - Drive shaft, output shaft, and/or gear splines worn
- Overshifts
 - Shift return spring pin loose

ABNORMAL ENGINE NOISE

- Knocking
 - Ignition timing maladjusted
 - Carbon built up in combustion chamber
 - Fuel poor quality or incorrect
 - Overheating
- Piston Slap
 - Cylinder/piston clearance excessive
 - Cylinder, piston worn
 - Connecting rod bent
 - Piston pin, piston holes worn
- Other Noise
 - Connecting rod small end clearance excessive
 - Connecting rod big end clearance excessive
 - Piston ring(s) worn, broken, or stuck
 - Piston seizure damage
 - Cylinder head gasket leaking
 - Exhaust pipe leaking at cylinder connection
 - Crankshaft bearing worn
 - Crankshaft runout excessive
 - Engine mounts loose

ABNORMAL DRIVE TRAIN NOISE

- Clutch Noise
 - Clutch housing/steel plate clearance excessive
 - Input gear/primary gear backlash
 - Transmission bearings, bushes worn
 - Metal chips jammed in primary drive gear teeth
- Transmission noise
 - Transmission bearings worn
 - Transmission gears worn or chipped
 - Metal chips jammed in gear teeth
 - Transmission oil insufficient or too thin
 - Ratchet not properly disengaging from kick gear
- Drive Chain Noise
 - Chain worn
 - Rear and/or engine sprocket(s) worn
 - Chain lubrication insufficient
 - Rear wheel misaligned

ABNORMAL FRAME NOISE

- Front Fork Noise
 - Spring weak or broken
- Rear Shock Absorber Noise
 - Shock absorber defective

82 APPENDIX - TROUBLESHOOTING GUIDE

Brake Noise

- Brake linings overworn or worn unevenly
- Drum worn unevenly or scored
- Brake spring(s) weak or broken
- Foreign matter in hub
- Brake not properly adjusted

Other Noise

- Brackets, nuts, bolts, etc., not properly mounted or tightened

EXHAUST SMOKE

White smoke

- Throttle control cable maladjusted
- Oil poor quality or incorrect
- Crankshaft oil seal defective
- Air cleaner clogged
- Main jet too large or fallen off
- Starter plunger stuck open
- Float level too high

Brownish Smoke

- Throttle control cable maladjusted
- Oil pump defective
- Oil line or check valve clogged
- Air in oil pump or oil line
- Air cleaner poorly sealed or missing
- Float level too low

HANDLING and/or STABILITY UNSATISFACTORY

Handlebar Hard to Turn

- Steering stem nut too tight
- Bearings damaged
- Steering stem lubrication inadequate
- Steering stem bent
- Tire air pressure too low

Handlebar Shakes or Excessively Vibrates

- Tire(s) worn
- Swing arm bushing damaged
- Rim(s) warped
- Front, rear axle runout excessive
- Wheel bearing(s) worn
- Handlebar clamp(s) loose

Handlebar Pulls to One Side

- Frame bent
- Wheel misalignment
- Swing arm bent
- Swing arm pivot shaft runout excessive
- Steering stem bent
- Front fork shock absorber(s) bent
- Right/left rear shock absorbers unbalanced

Shock Absorption Unsatisfactory

Too Hard:

- Tire air pressure too high

Too soft:

- Front fork, rear shock absorber spring(s) weak

BRAKE DOESN'T HOLD

- Brake not properly adjusted
- Linings overworn or worn unevenly

Drum worn unevenly or scored
 Cam, camshaft, shaft hole worn
 Oil, grease on lining and drum
 Dirt, water between lining and drum
 Overheated

NOTE: This not an exhaustive list, giving every possible cause for each problem listed. It is meant simply as a rough guide to assist the troubleshooting for some of the more common difficulties. Electrical troubleshooting is not covered here due to its complexity. For electrical problems, refer to the appropriate heading in the Maintenance Section.

Wiring Diagram

